

Build an ARTS & CRAFTS TALL CLOCK p.38

JUNE/JULY 2004 ISSUE 156

Better Homes and Gardens®

BRUSH ON
A PERFECT
VARNISH FINISH p.92

WOOD®

mortise & tenon joints made *very* easy

3 goofproof ways show you how p.68

8 MUST-MAKE PROJECTS for your home, yard, & shop

BONUS POSTER
YOUR GUIDE TO
WORKSHOP
GLUES p.59

Display until July 20, 2004

U.S.A. \$6.99

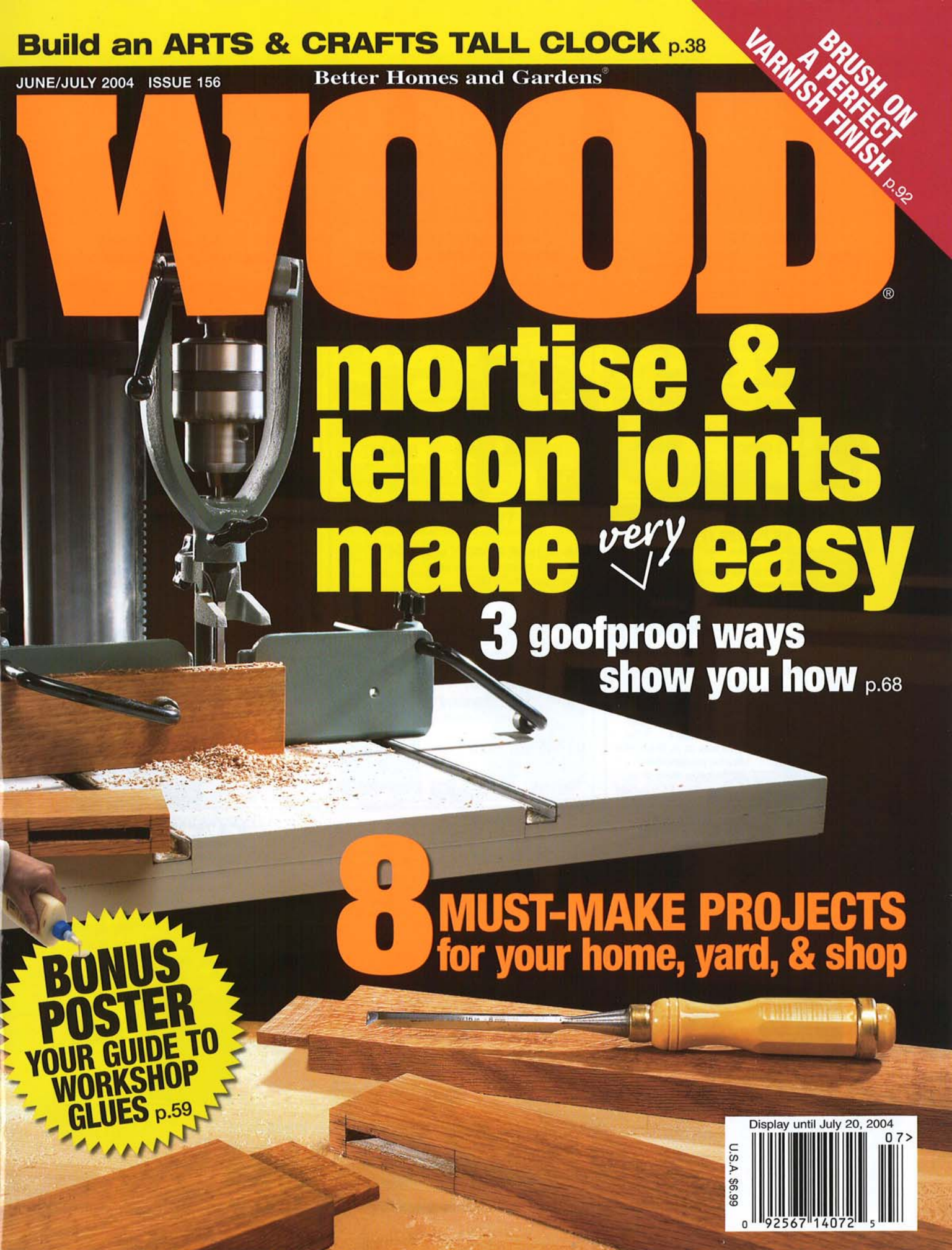



Grizzly Industrial

PURVEYORS OF FINE MACHINERY®

NO DEALERS • NO MIDDLEMEN • BUY DIRECT & SAVE!

2 HP DUST COLLECTOR

3 MICRON BAG!

- MOTOR: 2 HP, 220V, SINGLE-PHASE, 3450 RPM
- AIR SUCTION CAPACITY: 1550 CFM
- STATIC PRESSURE: 11"
- 6" INLET HAS REMOVABLE "Y" FITTING W/ TWO 4" OPENINGS
- STANDARD BAG FILTRATION: .3 MICRONS
- HEIGHT W/ BAG INFLATED: 78"
- APPROX. SHIPPING WEIGHT: 123 LBS.

FREE 2-STAGE CYCLONE SEPARATOR WITH PURCHASE OF G1029Z

MADE IN ISO 9001 FACTORY!

G1029Z

SPECIAL PRICE
\$259⁹⁵

\$55 ANYWHERE IN LOWER 48 STATES



New!

THE ULTIMATE 10" CONTRACTOR STYLE TABLE SAW

- MOTOR: 2 HP, 110V/220V, SINGLE-PHASE
- PRECISION GROUND CAST IRON TABLE W/WINGS MEASURES: 27" x 39 5/8"
- ARBOR: 3/4" • RIP CAPACITY: 30"
- CUTTING CAPACITY: 3 1/8" @ 90°, 2 1/4" @ 45°
- SHOP FOX® ALUMA-CLASSIC™ FENCE

• APPROX. SHIPPING WEIGHT: 298 LBS.

New!
MADE IN AN ISO 9001 FACTORY!



PRECISION GROUND TABLE & WINGS FOR A MIRROR-LIKE FINISH & THE ULTIMATE IN ACCURACY!

G0444Z

INTRODUCTORY PRICE
ONLY \$525⁰⁰

\$75 ANYWHERE IN LOWER 48 STATES

10" TILTING ARBOR SUPER HEAVY-DUTY TABLE SAW

- MOTOR: 3 HP, 220V, SINGLE-PHASE
- PRECISION GROUND CAST IRON TABLE
- TABLE SIZE W/ WINGS ATTACHED: 27" x 40"
- ARBOR DIAMETER: 3/4" (ACCEPTS DADO BLADES UP TO 1 3/16")
- CUTTING CAPACITY: 8" LEFT & 26" RIGHT OF BLADE
- APPROX. SHIPPING WEIGHT: 420 LBS.

TOOL BUYING GUIDE Editors' Choice

BEST NEW TOOL

2002 FACTORY STOCK



INCLUDES SHOP FOX® CLASSIC FENCE

G1023S REG. \$825⁰⁰
SALE \$795⁰⁰

\$75 ANYWHERE IN LOWER 48 STATES

POWER FEEDERS

1/2 HP POWER FEEDER

- MOTOR: 1/2 HP, 220V, SINGLE-PHASE, 4 AMP
- NUMBER OF SPEEDS: 4
- FEED SPEEDS: 9.5, 15, 25 & 38 FPM
- ROTATION: FORWARD & REVERSE
- ROLLERS: 3 SYNTHETIC RUBBER
- ROLLER SIZE: 2" W x 4" DIA.
- APPROX. SHIPPING WEIGHT: 107 LBS.

MADE IN ISO 9001 FACTORY!

G4179 REG. \$599⁹⁵
SALE \$579⁹⁵

\$55 ANYWHERE IN LOWER 48 STATES

OUR MOST POPULAR FEEDER!

1/4 HP POWER FEEDER

- MOTOR: 1/4 HP, 110V, SINGLE-PHASE, 1.8 AMP
- NUMBER OF SPEEDS: 4
- SPEED RANGE: 20, 26, 33 & 43 FPM
- ROTATION: FORWARD & REVERSE
- APPROX. SHIPPING WEIGHT: 80 LBS.

MADE IN ISO 9001 FACTORY!

G4176 ONLY \$399⁹⁵

\$40 ANYWHERE IN LOWER 48 STATES



1 1/2 HP SHAPER

(SHOWN WITH OPTIONAL WING G1706)

- MOTOR: 1 1/2 HP, 110V/220V, SINGLE-PHASE
- PRECISION GROUND CAST IRON TABLE
- TABLE SIZE: 20 1/4" x 18"
- 2 INTERCHANGEABLE SPINDLES: 1/2" & 3/4"
- SPINDLE TRAVEL: 3"
- SPINDLE OPENINGS: 1 1/4", 3/8", & 5"
- 2 SPINDLE SPEEDS: 7000 & 10,000 RPM
- MAX. CUTTER DIAMETER: 5"
- APPROX. SHIPPING WEIGHT: 220 LBS.

INCLUDES MITER GAUGE & FENCE

G1035 REG. \$425⁰⁰

SALE \$410⁰⁰

\$55 ANYWHERE IN LOWER 48 STATES



3 HP SHAPER

- MOTOR: 3 HP, 220V, SINGLE-PHASE W/REVERSING SWITCH
- PRECISION GROUND CAST IRON TABLE
- TABLE SIZE WITH STANDARD WING ATTACHED: 30 1/2" x 28 1/4"
- 3 INTERCHANGEABLE SPINDLES: 1/2", 3/4" & 1"
- 2 SPINDLE SPEEDS: 7,000 & 10,000 RPM
- SPINDLE TRAVEL: 3"
- SPINDLE OPENINGS: 1 1/8", 2 1/4", 4", AND 5 1/2"
- APPROX. SHIPPING WEIGHT: 357 LBS.

HOTTEST SHAPER IN THE USA!

INCLUDES MITER GAUGE & FENCE W/ HOLD-DOWN SPRINGS

G1026 REG. \$835⁰⁰

SALE \$795⁰⁰

\$75 ANYWHERE IN LOWER 48 STATES



6" X 47" JOINTER W/ HANDWHEELS

- MOTOR: 1 HP, 110V/220V, SINGLE-PHASE
- PRECISION GROUND CAST IRON TABLE
- CUTTERHEAD: 3 HSS KNIVES
- MAXIMUM DEPTH OF CUT: 1/2"
- RABBETING CAPACITY: 1/2"
- HANDWHEELS FOR TABLE HEIGHT ADJUSTMENT
- HEAVY-DUTY CENTER MOUNTED FENCE

• APPROX. SHIPPING WEIGHT: 225 LBS.

TOOL BUYING GUIDE Editors' Choice

FREE PAIR OF SAFETY PUSH BLOCKS

G1182HW
INTRODUCTORY PRICE
ONLY \$325⁰⁰

\$55 ANYWHERE IN LOWER 48 STATES



6" X 60" ANNIVERSARY EDITION JOINTER W/ SPIRAL CUTTERHEAD

- MOTOR: 1 1/2 HP, 110V/220V, SINGLE-PHASE
- PRECISION GROUND CAST IRON TABLE
- TABLE SIZE: 7 1/4" x 60"
- CUTTERHEAD SPEED: 4800 RPM
- MAXIMUM DEPTH OF CUT: 1/8"
- HEAVY-DUTY CENTER MOUNTED FENCE
- APPROX. SHIPPING WEIGHT: 280 LBS.

New!

FREE PAIR OF SAFETY PUSH BLOCKS

G0526
INTRODUCTORY PRICE
ONLY \$850⁰⁰

\$55 ANYWHERE IN LOWER 48 STATES



8" X 75" JOINTER W/ SPIRAL CUTTERHEAD

- MOTOR: 2 HP, 110V/220V, SINGLE-PHASE, TEFC
- PRECISION GROUND CAST IRON TABLE
- TABLE SIZE: 8" x 75" INCLUDES TWO 5" EXTENSIONS
- SPIRAL CUTTERHEAD REDUCES TEAR-OUT
- CUTTERHEAD SPEED: 5500 RPM
- MAXIMUM DEPTH OF CUT: 1/2"
- HEAVY-DUTY CENTER MOUNTED FENCE
- APPROX. SHIPPING WEIGHT: 484 LBS.

New!

G0543
INTRODUCTORY PRICE
ONLY \$1195⁰⁰

\$75 ANYWHERE IN LOWER 48 STATES

FREE PAIR OF SAFETY PUSH BLOCKS



MEDIA CODE
AD 2105

5997

24 HOUR ORDERING!

1-800-523-4777

CUSTOMER SERVICE: 570-546-9663 CSR@GRIZZLY.COM • FAX: 1-800-438-5901

3 FANTASTIC SHOWROOMS:
BELLINGHAM, WA
MUNCY, PA
SPRINGFIELD, MO

ANNUAL SUMMER SALE

MAY 15TH THROUGH SEPTEMBER 1ST

- ALMOST A MILLION SQUARE FEET PACKED TO THE RAFTERS WITH MACHINERY & TOOLS
- 2 OVERSEAS QUALITY CONTROL OFFICES STAFFED WITH QUALIFIED GRIZZLY ENGINEERS
- HUGE PARTS FACILITY WITH OVER 1 MILLION PARTS IN STOCK AT ALL TIMES
- TRAINED SERVICE TECHNICIANS AT EACH LOCATION • MOST ORDERS SHIPPED THE SAME DAY

**DON'T MISS OUT
ON AMAZING
PRICES & FANTASTIC DEALS!**

**THIS IS ONE OF OUR BIGGEST
EVENTS OF THE YEAR!**

THE ULTIMATE 14" BANDSAW

- MOTOR: 1 HP, 110V/220V, SINGLE-PHASE, TEFC
- PRECISION GROUND CAST IRON TABLE
- TABLE TILT: 45° RIGHT, 10° LEFT
- FLOOR TO TABLE HEIGHT: 43 1/8"
- DELUXE EXTRUDED ALUMINUM FENCE
- CUTTING CAPACITY/THROAT: 13 1/2"
- MAXIMUM CUTTING HEIGHT: 6"
- BLADE SIZE: 92 1/2" - 93 1/2" LONG (1/4" - 3/4" WIDE)
- 2 BLADE SPEEDS: 1500 & 3200 FPM
- 4" DUST PORT
- APPROX. SHIPPING WEIGHT: 198 LBS.



MADE IN
ISO 9001 FACTORY!



G0555
ONLY \$375⁰⁰

\$55 ANYWHERE IN LOWER 48 STATES

17" HEAVY-DUTY BANDSAW

- MOTOR: 2 HP, 110V/220V, SINGLE-PHASE, TEFC
- PRECISION GROUND CAST IRON TABLE
- TABLE TILT: 45° RIGHT, 10° LEFT
- FLOOR TO TABLE HEIGHT: 37 1/2"
- CUTTING CAPACITY/THROAT: 16 1/4"
- MAXIMUM CUTTING HEIGHT: 12"
- BLADE SIZE: 131 1/2" LONG (1/4" - 1" WIDE)
- 2 BLADE SPEEDS: 1600 & 3300 FPM
- TWO 4" DUST PORTS
- APPROX. SHIPPING WEIGHT: 342 LBS.



CAST IRON FENCE, MITER GAUGE
& 1/2" BLADE INCLUDED

MADE IN
ISO 9001 FACTORY!

G0513
ONLY \$750⁰⁰

\$75 ANYWHERE IN LOWER 48 STATES

19" HEAVY-DUTY BANDSAW

- MOTOR: 2 HP, 110V/220V, SINGLE-PHASE, TEFC
- PRECISION GROUND CAST IRON TABLE
- CUTTING CAPACITY/THROAT: 18 1/4"
- MAX. CUTTING HEIGHT: 12"
- BLADE SIZE: 143" LONG (1/4" - 1 1/4" WIDE)
- 2 BLADE SPEEDS: 1700 & 3500 FPM
- TWO 4" DUST PORTS
- APPROX. SHIPPING WEIGHT: 385 LBS.



MADE IN ISO 9001 FACTORY!

CAST IRON FENCE, MITER GAUGE
& 1/2" BLADE INCLUDED

G0514 REG. \$950⁰⁰
SALE \$925⁰⁰

\$75 ANYWHERE IN LOWER 48 STATES

12 1/2" LEAN & MEAN PORTABLE PLANER

- MOTOR: 2 HP, 110V, SINGLE-PHASE
- MAX. CUTTING WIDTH: 12 1/2"
- MAX. CUTTING DEPTH: 3/8"
- MAX. CUTTING HEIGHT: 6"
- MIN. BOARD THICKNESS: 3/16"
- FEED RATE: 32 FPM
- ON/OFF TOGGLE SWITCH
- CUTTERHEAD SPEED: 10,000 RPM
- CUTS PER INCH: 52
- APPROX. SHIPPING WEIGHT: 78 LBS.



HOT!

\$35 ANYWHERE IN LOWER 48 STATES

G0505
REG. \$195⁰⁰
SALE \$185⁰⁰

15" PLANER w/ CLOSED STAND

- MOTOR: 3 HP, 220V, SINGLE-PHASE
- MAX. CUTTING WIDTH: 14 1/4"
- MAX. CUTTING DEPTH: 1/8"
- MAX. CUTTING HEIGHT: 6 1/4"
- MIN. BOARD THICKNESS: 3/16"
- 3 HSS KNIVES
- FEED RATE: 16 & 20 FPM
- CUTTERHEAD SPEED: 5000 RPM
- CUTS PER MINUTE: 15,000
- APPROX. SHIPPING WEIGHT: 560 LBS.

New!



ROLLER EXTENSION
TABLES FEATURE 3
ADJUSTABLE ROLLERS

G0551
INTRODUCTORY PRICE
ONLY \$675⁰⁰

\$125 ANYWHERE IN LOWER 48 STATES

12 SPEED 20" FLOOR DRILL PRESS

- MOTOR: 1 1/2 HP, 110V/220V, SINGLE-PHASE
- PRECISION GROUND CAST IRON TABLE
- TABLE SIZE: 18 1/4" x 16 1/4"
- SPINDLE TAPER: MT#4
- SPINDLE TRAVEL: 4 1/4"
- SWING: 20"
- DRILL CHUCK: 3/8"
- 12 SPEEDS: 210 - 3300 RPM
- DRILLING CAPACITY: 1 1/4" STEEL
- OVERALL HEIGHT: 70"
- APPROX. SHIPPING WEIGHT: 331 LBS.

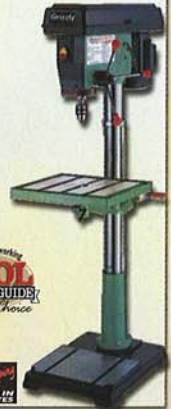

NICE
MACHINE!

Popular Woodworking
TOOL
BUYING GUIDE
Editor's Choice

G7948
ONLY \$425⁰⁰

\$75 ANYWHERE IN LOWER 48 STATES

OSCILLATING SPINDLE/ 12" DISC SANDER

- MOTOR: 1 HP, 110V, SINGLE-PHASE, TEFC
- CAST IRON 14 1/2" SQUARE OSCILLATING SANDER TABLE
- CAST IRON 17 1/2" x 10" DISC SANDER TABLE
- FOUR SPINDLE SIZES: 1/4", 3/8", 1/2" & 2"
- SPINDLE SPEED: 1725 RPM
- SPINDLE OSCILLATIONS: 60 SPM
- STROKE LENGTH: 1"
- 2 - 2" DUST PORTS
- APPROXIMATE SHIPPING WEIGHT: 180 LBS.



MADE IN
ISO 9001
FACTORY!

\$55 ANYWHERE IN LOWER 48 STATES

G0529
INTRODUCTORY PRICE
ONLY \$395⁰⁰

New!

24" DRUM SANDER WITH VARIABLE SPEED

- DRUM MOTOR: 5 HP, 220V, SINGLE-PHASE
- CONVEYOR MOTOR: 1/4 HP, VARIABLE SPEED
- SANDING DRUMS: 2 COMPUTER BALANCED ALUMINUM
- MAX. STOCK SIZE: 23 1/2" x 4 1/4" THICK
- HOOK & LOOP SANDPAPER
- CONTROL PANEL w/ AMP LOAD METER
- TWO 4" DUST PORTS
- APPROX. SHIPPING WEIGHT: 489 LBS.

VARIABLE
SPEED!

SERIES

\$75 ANYWHERE IN LOWER 48 STATES

G1066Z
REG. \$1595⁰⁰
SALE \$1550⁰⁰



15" WIDE-BELT SANDER (OPEN END)

- SANDING BELT MOTOR: 5 HP, 220V, SINGLE-PHASE
- FEED BELT MOTOR: 1/4 HP
- CONVEYOR SPEED: 13.1 & 16.4 FPM
- AMP METER
- PNEUMATIC BELT TENSIONING & TRACKING
- DISC BRAKE FOR EMERGENCY STOPS
- INCLUDES EXTENDED SUPPORT BAR FOR WIDE BOARDS
- APPROX. SHIPPING WEIGHT: 908 LBS.



\$150 ANYWHERE IN LOWER 48 STATES

G9983
REG. \$2795⁰⁰
SALE \$2750⁰⁰



OVER 12,000
PRODUCTS
ONLINE!

grizzly.com

VISIT OUR WEBSITE
FOR THE LATEST INFO
ON SALES &
SPECIAL EVENTS





SHIFT innovation

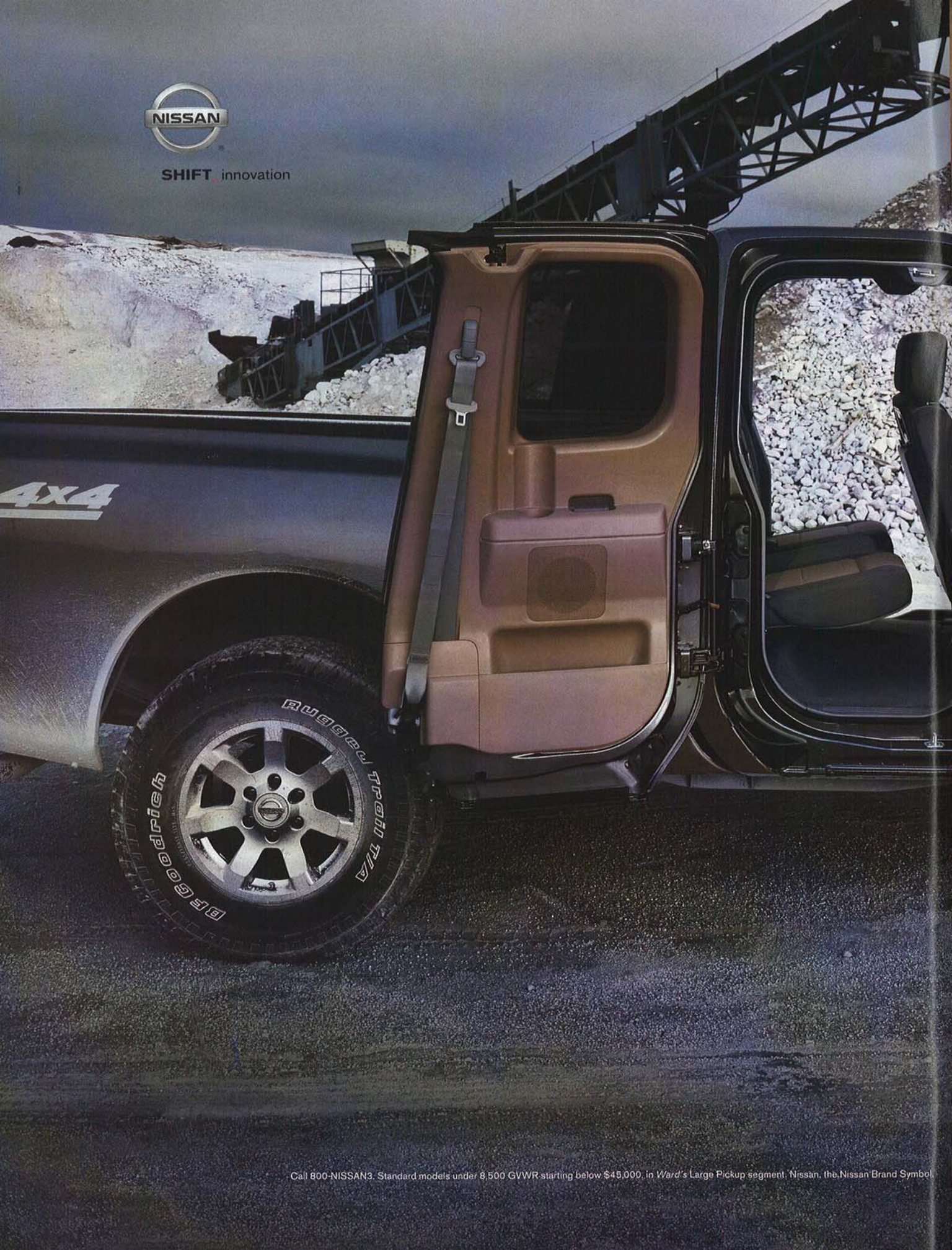

Call 800-NISSAN3. Standard models under 8,500 GVWR starting below \$45,000, in Ward's Large Pickup segment. Nissan, the Nissan Brand Symbol.

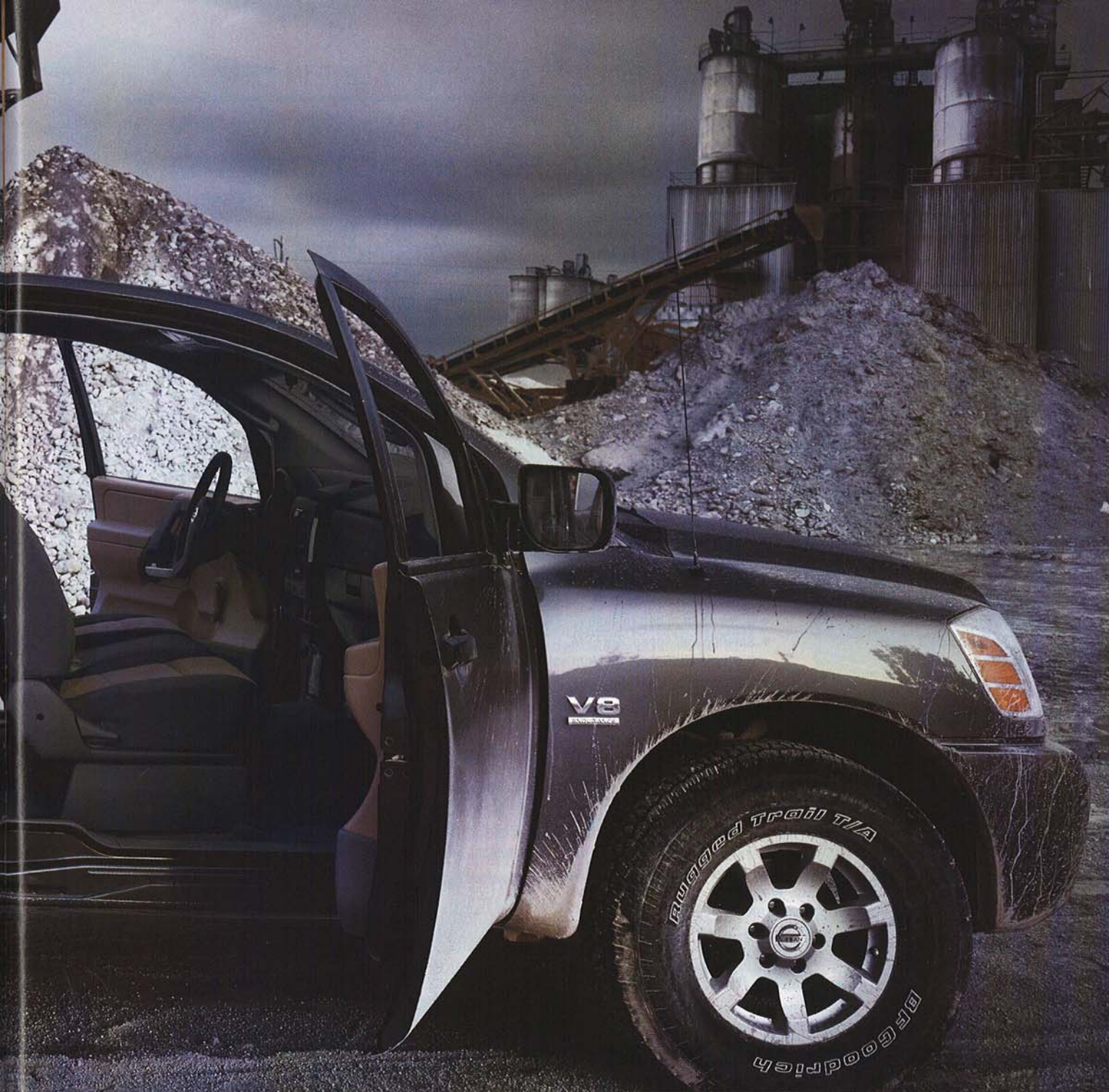

168° REAR DOORS	THE FULL-SIZE NISSAN TITAN	
	MODEL 4X4 KING CAB	ENGINE 5.6L DOHC V8
ARE 77° MORE INVITING THAN OTHER TRUCK DOORS.	TORQUE 379 LB-FT @ 3600 RPM	HP 305 @ 4900 RPM
	OTHER WIDEST-OPENING REAR DOORS IN ITS CLASS	
	AWARD AUTOMOBILE MAGAZINE'S 2004 ALL-STAR FOR PICKUP TRUCK	
	MFG. IN CANTON, MISSISSIPPI • NISSANUSA.COM	

U.S.-manufactured Nissans consist of domestic and globally sourced parts.
"SHIFT" tagline and Nissan model names are Nissan trademarks. Tread Lightly!™ Please. Always wear your seat belt, and please don't drink and drive. ©2003 Nissan North America, Inc.

FASTEST GROWING MACHINERY LINE IN THE U.S.A.

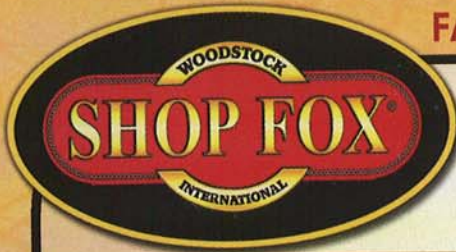

INNOVATIVE PRODUCTS DESIGNED FOR PRACTICAL USE

WE DESIGN OUR MACHINES TO THE MOST STRINGENT STANDARDS, TRIPLE CHECK EACH ONE FOR QUALITY ASSURANCE AND BACK EVERY MACHINE WITH A FULL TWO-YEAR WARRANTY!



HEAVY-DUTY COMBINATION SANDER

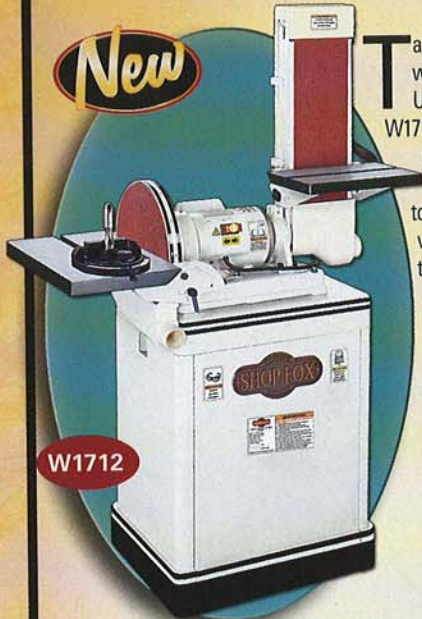

New

W1712

Tackle your tougher sanding operations with this rugged and reliable machine. Unlike many belt-driven sanders, the W1712 uses a direct ball bearing drive from the motor to the sanding disc and belt to deliver a vibration-free positive torque flow. For increased sanding versatility and control, both cast iron tables accept the miter gauge.

- ◆ 1½ HP, 110V, single-phase motor
- ◆ Precision ground cast iron tables
- ◆ Sanding belt size: 6" x 48"
- ◆ Disc size: 12"
- ◆ Quick change belt release
- ◆ Sanding belt speed: 878 FPM
- ◆ Disc speed: 1725 RPM
- ◆ Approx. shipping weight: 178 lbs.

MORTISING MACHINE



W1671

We designed this machine for mortising ease. The super heavy-duty fence & hold down eliminates unwanted wood movement and "sticking chisels". Unique swiveling base allows easy off the bench operations while the extra height and depth capacity allows the use of much larger stock. Features like a 22" long solid steel quick-positioning handle, 8-tool holder, easy two-door chuck access, large base and twin hardened and ground columns insure perfect mortises every time.

- ◆ ¾ HP, 3450 RPM motor
- ◆ Adjustable depth stop rod
- ◆ Mortises lumber to 8¾" thick
- ◆ Jacobs taper #2 spindle
- ◆ Double support columns
- ◆ ½" JT #2 chuck
- ◆ Approx. shipping weight: 90 lbs.

PATENT PENDING

2 HP, 10" CONTRACTOR TYPE SAW



New

W1714

This machine is ready to rip with heavy-duty cast iron extension wings and the new Shop Fox® AlumClassic™ Fence. A sturdy base, cast iron miter gauge with adjustable quick stops, and a rail mounted magnetic switch are some standard features that make this saw irresistible to contractors and home shop woodworkers alike. Weighing in at 292 lbs., this saw will provide operating stability for better cutting accuracy.

- ◆ 2 HP, 110V/220V, single-phase motor
- ◆ Precision ground cast iron table with T-slots
- ◆ Table size: 39½" x 27" (with cast iron extension wings)
- ◆ Max. depth of cut: 3½"
- ◆ Ripping capacity: 28"
- ◆ Arbor speed: 4250 RPM
- ◆ Approx. shipping weight: 310 lbs.

10" LEFT TILT TABLE SAW



W1677
3 HP

New
W1711
SHOP FOX®
10" Left Tilt Table Saw
with 5 HP Motor

With a left tilting blade and nearly 450 lbs. of vibration dampening mass, this saw will definitely take center stage in any shop. We've included 2 large cast iron wings, a jumbo miter gauge with patented adjustment feature, and a powerful 3 or 5 HP motor with triple drive belt system. The Shop Fox® Classic Fence with a 26" rip capacity provides a compact and sturdy means for dependable and accurate ripping. (Longer rails are available.)

- ◆ 3 or 5 HP, 220V, single-phase motor
- ◆ Precision ground cast iron table with T-slots
- ◆ Table size: 40½" x 27" with wings
- ◆ Max. blade height: 3"
- ◆ Ripping capacity: 26" standard
- ◆ Arbor speed: 4250 RPM
- ◆ Approx. shipping weight: 552 lbs.

SHOP FOX® is a registered trademark of Woodstock International, Inc.

sales@shopfox.biz

TO SEE OUR INNOVATIVE MACHINES
AT AN AUTHORIZED DEALER, PLEASE
CALL FOR THE LOCATION OF A DEALER NEAR YOU!

SHOPFOX.BIZ ◆ 1-800-840-8420

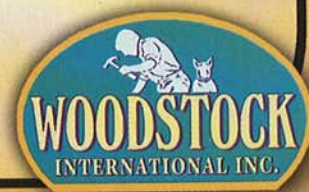

WOOD

June/July 2004, Issue 156

PROJECTS

- 22 portable glue/paper towel center
- 38 heirloom tall clock
- 52 feature-packed drill-press table
- 65 letter opener
- 74 build-in-a-weekend garden bench
- 94 wind chimes
- 96 classic turned mallet

TECHNIQUES

- 28 epoxy: a pro's tips
- 32 how to show off quartersawn oak
Discover the tricks for playing up eye-grabbing ray-fleck figure in project parts.
- 48 building chairs with Sam Maloof
See how a renowned master craftsman designs and assembles his signature furniture pieces.
- 66 how to deal with wood moisture
- 68 master the mortise-and-tenon joint
From low-tech to dedicated machines, get to know three ways for making snug-fitting parts.
- 84 get a grip on four-jaw chucks
Learn the advantages and use of this problem-solving lathe accessory.
- 92 brush on a flawless varnish finish

TOOLS & MATERIALS

- 14 wise buys: Japanese pull saws
- 59 **BONUS POSTER:**
guide to woodworking glues
- 78 shop-tested benchtop mortisers
Seven moderately priced models compete to earn our prestigious "top tool" rating.
- 88 2004 tool storage contest winners
Check out 13 of the best shop projects from around the nation.
- 100 hollow mortise chisels
Get maximum performance from your cutters with these pointers on use and care.
- 115 rated: three shop-proven products

DEPARTMENTS

- 8 editor's angle
- 10 sounding board
- 16 sanding-drum dust collector
- 18 short cuts
- 24 ask WOOD
- 36 wood words
- 104 shop tips
- 110 curious craftsman
- 120 what's ahead

SPECIAL SECTION

Mortise-and-Tenon Joinery



68 The techniques...

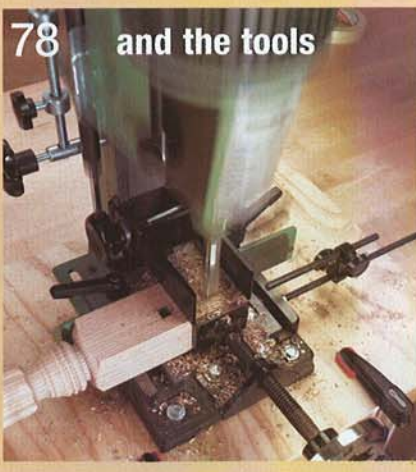

78 and the tools



88



52

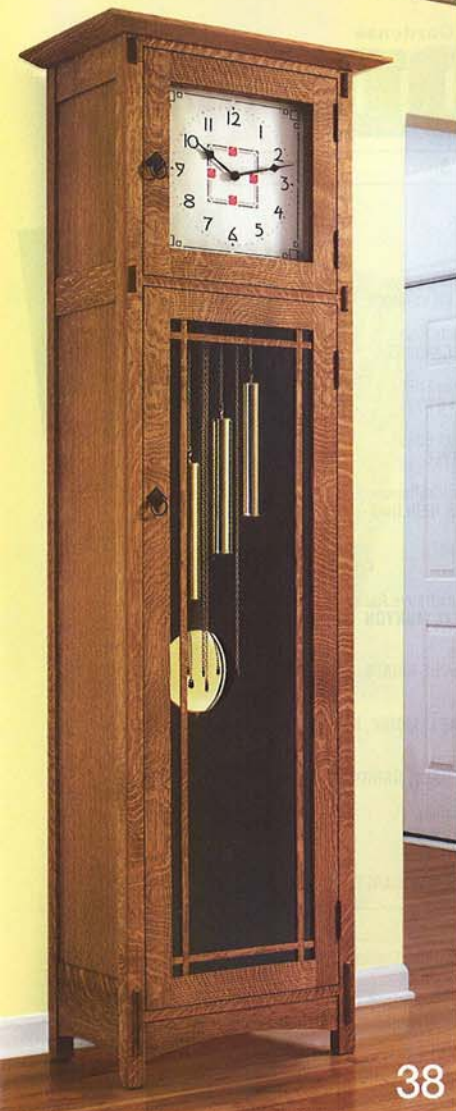

38



14



74



This seal is your assurance that we build every project, verify every fact, and test every reviewed tool in our workshop to guarantee your success and complete satisfaction.

GREAT AMERICAN BACKYARD

—contest—

DECK OUT YOUR YARD WITH A \$10,000 BACKYARD MAKEOVER

Using a natural palette and textured finishes, you too can transform timeworn patio furniture and accessories into a stylish outdoor living space.

Send a 100 word or less creative essay telling us why your backyard is the ideal candidate for a makeover. Include a color photo of your yard.



Every entrant receives a free Dream Spaces decorating booklet that will help you create your own makeover. The winner gets a \$10,000 backyard makeover complete with a professional design consultant.



RUST-OLEUM®

stopping rust is just the start.™

No purchase necessary. Contest is open from 5/15/2004 — 7/31/2004 to homeowners age 21 and over who are legal US residents. Enter online at great-american-backyard.com or mail photo and essay with full name, date of birth, address (with zip code) and telephone number to: Rust-Oleum Great American Backyard Contest, c/o ARS, 43 N. Canal Street, Chicago IL 60606. Entries must be postmarked July 31, 2004. Void where prohibited. For official rules and judging criteria, visit great-american-backyard.com, or send a self-addressed stamped envelope to: Rust-Oleum Great American Backyard Contest, c/o ARS, 43 N. Canal Street, Chicago IL 60606.

© 2004 Rust-Oleum Corporation

Better Homes and Gardens®

WOOD

June/July 2004

Vol. 21, No. 3

Issue No. 156

EDITOR-IN-CHIEF
BILL KRIER

Executive Editor
JIM HARROLD

Managing Editor
MARLEN KEMMET

Senior Design Editor
KEVIN BOYLE

Products Editor
DAVE CAMPBELL

Techniques Editor
JIM POLLOCK

Features Editor
DAVID STONE

Projects Editor
OWEN DUVALL

Projects Editor
JAN SVEC

Design Editor
JEFF MERTZ

Master Craftsman
CHUCK HEDLUND

Art Director
KARL EHLERS

Associate Art Director
GREG SELLERS

Assistant Art Director
CHERYL A. CIBULA

Production/Office Manager
MARGARET CLOSNER

Administrative Assistant
SHERYL MUNYON

Photographers
MARTY BALDWIN, SCOTT LITTLE, BLAINE MOATS, JAY WILDE

Illustrators
TIM CAHILL, LORNA JOHNSON, ROXANNE LeMOINE, MIKE MITTERMEIER

Technical Consultants
JOHN CEBUJAR, DEAN FIENE, JEFF HALL, GARRY SMITH

Contributing Craftsman
JIM HEAVEY

Proofreaders
BARBARA KLEIN, JIM SANDERS, MARGARET SMITH

Publisher MARK HAGEN

ADVERTISING OFFICE: 333 N. Michigan Ave., Suite 1500, Chicago, IL 60601

Phone: 312/853-2890 Fax: 312/580-7906

Sales and Marketing Assistant NEILLE MORRIS

Account Executive JACK A. CHRISTIANSEN

Direct Response Manager CAROLYN DAKIS

Direct Response Sales Representative SANDY ROBINSON

Account Executive JOHN THORNBURGH Detroit,

Phone: 248/356-1149 Fax: 248/356-8930

Account Executive PATRICK R. TOMLINSON, SR. Northeast,

Phone: 212/551-7043 Fax: 212/551-7192

Southeast: Lagomarsino, Dempsey & Dennis, Inc.

2951 Piedmont Rd. NE, Suite 100, Atlanta, GA 30305

Phone: 404/261-5400 Fax: 404/261-5404

Group Marketing Director CATHY E. SMITH

Senior Marketing Services Manager MARY M. WRIGHT

Senior Promotion Designer SARAH MASSIMO

Group Publisher STEPHEN B. LEVINSON

Associate Business Director CRAIG FEAR

Consumer Marketing Director ROBIN HUTCHINSON

Consumer Marketing Manager LESLIE SHAEFFER

Newsstand Product Manager LISA TROM

Advertising Operations Manager PAT HENDERSHOTT

Sr. Production Manager MICHAELA LESTER

Vice President/Publishing Director WILLIAM R. REED

MEREDITH PUBLISHING GROUP

President STEPHEN M. LACY

President, Magazine Group JACK GRIFFIN

Corporate Solutions MICHAEL BROWNSTEIN

Creative Services ELLEN DELATHOUER

Manufacturing BRUCE HESTON

Consumer Marketing KARLA JEFFRIES

Finance and Administration MAX RUNCIMAN

Meredith

CORPORATION
WILLIAM T. KERR, Chairman and Chief Executive Officer

In Memoriam — E.T. Meredith III (1933–2003)

©Copyright Meredith Corporation 2004
All rights reserved. Printed in the U.S.A.



Dave made three guitar stands like this one for Christmas presents.



Mark created this kneeler and screen for the confessional of his church.



Mary and Cathy built the keepsake box from issue 143.



ENJOY YOUR NEW LOOK.
 Because
IT'LL LAST
 — a long, long time. —

Take something old and make it new again. Protect against the elements and create a whole new look with Rust-Oleum, the name you've trusted for over eight decades. A vast palette of colors awaits you in the Painter's Touch® line of multi-purpose paints. Or, for a decorative flair, choose from the multitude of tones and textures in the American Accents® collection. Create tomorrow's treasures today. It's easy with Rust-Oleum.

RUST-OLEUM®
 stopping rust is just the start.™



The Toughest Glue On Planet Earth



**Wood, Stone, Metal,
Ceramic, & More!**

Gorilla Glue is the versatile, interior/exterior adhesive ideal for most household fixes and building projects: furniture repair, crafts, woodworking, and general repairs around the house. Bonds wood, stone, metal, ceramic & more! Incredibly strong and 100% waterproof.



**REQUEST YOUR FREE
INFORMATION KIT!**

www.gorillaglu.com

1-800-966-3458

Circle No. 50

editor's angle

air-dried wood: just as good as kiln-dried?

There's a common woodworking myth that air-dried wood is more prone to warping, shrinking, or expanding than kiln-dried wood. Don't believe it—doing so could cost you serious dough when buying boards.

It happened 15 years ago, but I still vividly remember the day I passed up the best lumber deal of my life. It was at a farm auction where the entire contents of a small shed were up for sale. That shed was stuffed to its rafters with a thousand or so board feet of beautiful walnut planks. They had been carefully stacked and stickered, appeared completely dry and flat, and, according to the auctioneer, had been sitting there for at least 25 years. All day long I hadn't found anything at that auction I wanted, but this pile of walnut was different. I yearned for it.

As the bidding began, I told my companions (both experienced woodworkers) that I was ready to make a purchase.

"Be careful," one of them advised. "You don't know what you'll get with that air-dried stuff. It might split or warp months after you build something with it."

"Heck," the other friend said, "I built a coffee table with air-dried stock and it exploded right there in my living room!"

I had my doubts about their claims. For centuries our ancestors made beautiful, long-lasting furniture from air-dried stock, and that *explosion* was probably due to faulty joinery. But I decided not to take a chance, and put my auction number card back into my coat pocket. Big mistake.

The auctioneer started off asking \$150 for that wood: about 15 cents per board foot. And no one would pay it! Apparently, I was not the only victim who chose to give in to the myth and avoid taking a chance on air-dried stock. Eventually, some lucky soul paid \$75 for the entire lode.

Since that day, I've wised up in my wood-buying ways, and all of my research tells me that air-dried lumber is no worse



This pile of air-dried oak (parked where my wife used to put her van) has supplied the stock for dozens of projects over the past couple of years.

than kiln-dried stock, and often better. It's less likely to have "honeycombing" or the other defects that can result from hasty kiln drying, as described in Features Editor David Stone's report on page 66.

Of course air-drying takes time, typically 6–12 months for each inch of thickness. You need to dry the wood outside, then restack it inside for the final dry-down. You'll need a moisture meter to make sure the wood's moisture content reaches equilibrium with the relative humidity level in your shop and home (6–11 percent moisture content depending on where you live).

So why do lumber producers spend big money on kilns and the energy to run them? Because time is money and commercial kilns cut total drying time to about 6 weeks. Fortunately, few of us hobbyists are under such time pressures to produce lumber.

To learn more about air-dried stock, see issue number 59, pages 40–41, or go to woodmagazine.com/airdry. You'll find everything you need to air-dry your own stock, or buy it with confidence from someone else. Wish I had that information 15 years ago.

Bill Krier

Get Rid of Your Gutters!

RAINHANDLER[®]

Self-Cleans.

Unique louver design allows leaves and debris to blow or wash away.

Protects Property.

The Rainhandler self-cleaning system eliminates clogged, overflowing gutters and downspouts. No ground erosion. No more destructive ice dams from frozen gutters.

Protects You.

The Rainhandler self-cleaning system protects you from the need to climb ladders and roofs to clean clogged gutters.

Prevents Erosion.

Rainoff is converted to a 2 to 3 foot wide band of soft rain-sized droplets sprinkling the landscaping.

Maintains Itself.

The all-aluminum, never-rusting, maintenance-free Rainhandler louvers make messy, deteriorating gutters and downspouts history.

Beautifies.

The Rainhandler system is practically invisible. No gutters, downspouts, leaders or splash blocks to detract from the natural beauty of your home.

Installs Easily.

Each 5-foot section comes with 3 brackets & 6 screws. Do your entire home in 3 or 4 hours.

Guarantees.

Rainhandler comes with a 25-year manufacturer's warranty. Performance satisfaction is guaranteed for one full year.

Phone or Write for **FREE** Information

RAINHANDLER

Dept. WM0704

2710 North Avenue/Bridgeport, CT 06604

1-800-942-3004/Fax 1-800-606-2028

Name

Address

City State

Zip EMail

www.rainhandler.com/wm

sounding board

Our bulletin board for letters, comments, and timely updates

Bigger magazines need upsized storage

Thanks for growing the magazine by $\frac{3}{8}$ " in width and height (starting with issue 153) to make space for even more information.

Anyone who stores their back issues in the magazine boxes shown in issue 108 (page 50), though, has discovered the bigger issues are just a hair too tall to fit the box design. When readers make more storage boxes, they'll need to enlarge them accordingly.

Ralph Jones, London, Ohio

Here's an updated drawing. If you'd like the complete free plan, go to woodmagazine.com/magbox.

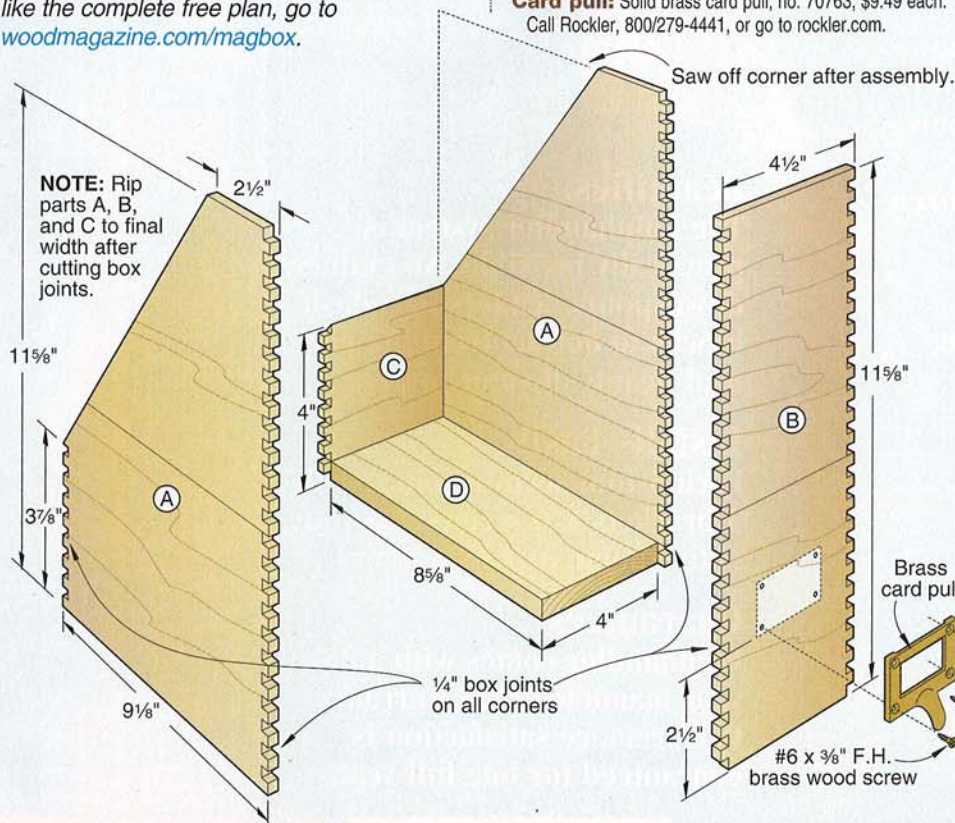

Materials List

Part	FINISHED SIZE			Matl.	Qty.
	T	W	L		
A* sides	1/4"	11 5/8"	9 1/8"	M	2
B* back	1/4"	11 5/8"	4 1/2"	M	1
C* front	1/4"	4"	4 1/2"	M	1
D bottom	1/2"	4"	8 5/8"	M	1

*Parts initially cut oversize, then ripped to finished width after cutting box joints. See the instructions.

Materials key: M—mahogany

Sources

Card pull: Solid brass card pull, no. 70763, \$9.49 each. Call Rockler, 800/279-4441, or go to rockler.com.

Article updates

Cat's meow scrollsawn plaque (issue 154, page 96): Locate the hole for the cutout block $2\frac{3}{16}$ " from the left edge of the plaque.

Super-flexible shop storage (issue 152, page 86): Locate the top three storage-bin mounting brackets in the Hardware Cabinet (Drawing 9) with $4\frac{1}{4}$ " spacing in between, as shown, below.

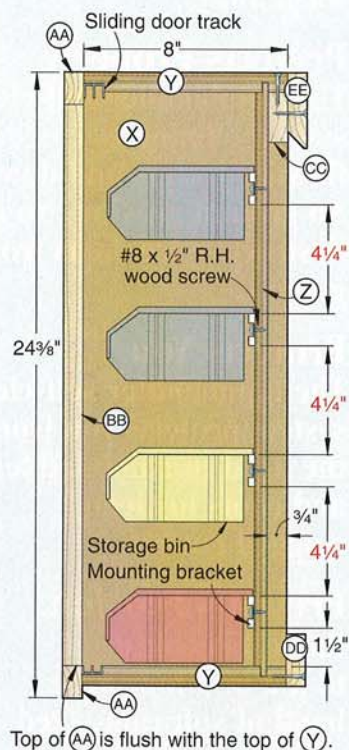

HOW TO REACH US

Editorial questions and feedback:

E-mail woodmail@woodmagazine.com; call 800/374-9663 and press option 2; or write to WOOD magazine, 1716 Locust St., GA-310, Des Moines, IA 50309-3023.

Subscription assistance:

To notify us of an address change or to get help with your subscription, go to woodmagazine.com/service; call 800/374-9663 and press option 1; or write to: WOOD magazine, P.O. Box 37439,

Boone, IA 50037-0439. Please enclose your address label from a recent magazine issue.

To find past articles:

Go to our continuously updated online index at woodmagazine.com/index.

To order past issues and articles:

Order past issues of WOOD® magazine and our newsstand special issues at woodstore.woodmall.com or by calling 800/346-9663. Be aware that many early issues

are sold out. For reprints, send \$5 per article (no phone orders), including the article name and issue number, to: WOOD Article Reprint Service, P.O. Box 349, Kalona, IA 52247; make check or money order payable to WOOD magazine.

Updates to previously published projects:

For a complete list of known changes in dimensions and buying guide sources from issue 1 through today, go to woodmagazine.com/editorial.

What Has A Thin Body, Big Teeth & Always Stays True?



LU83R
Thin Kerf
Combination Blade

The New Industrial Thin Kerf Saw Blade Series from Freud



A Must For Underpowered Saws

Less Power Needed

These new Industrial Thin Kerf Saw Blades remove less material, which reduces waste and feeds easier.



Extra Long Cutting Life

Freud develops and manufactures highly specialized MicroGrain carbide blends designed exclusively for a variety of cutting applications. Every cobalt and titanium formulation provides the perfect balance of long cutting life and razor sharp precision for each application. The oversized carbide teeth are 50-60% larger than standard carbide teeth resulting in up to 4 times more sharpenings.



No Stabilizer Needed

These blades also feature Freud's innovative anti-vibration technology that practically eliminates the sideways movement of the blade against the material. This design results in a quieter, smoother cut with a superior finish, and long cutting life that always stays true. For further performance, these new blades feature Freud's trademarked Perma-SHIELD™ Permanent High Performance Coating making the blade resistant to heat build-up and corrosion.

This new full range of thin kerf blades are designed for a variety of cutting applications in a wide range of sizes. Choose the blade that fits your application precisely, and maximize the performance of your saw.

freud®
Precisely what you need.

For Freud's full line of high quality saw blades go to:
www.freudtools.com
(U.S.) 1-800-472-7307
(Canada) 1-800-263-7016

Range includes but not limited too:



Your complete guide to

If you love *WOOD*® magazine, you'll truly enjoy our Internet sites and their many features. Our sites are designed to benefit you by complementing and expanding on the information you receive in every issue of *WOOD*.

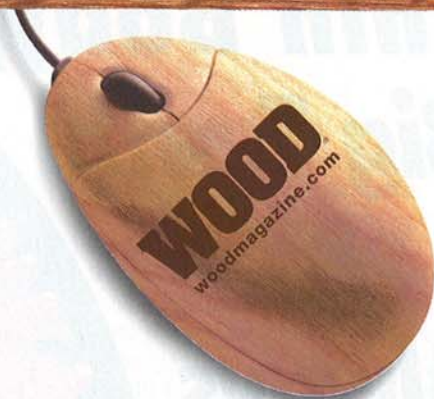

WOOD Online®

www.woodmagazine.com

WOOD Online prides itself as both a woodworking information center and an online woodworking community. Find the following at one of the Internet's most-visited woodworking sites:

- Searchable index for all past issues of *WOOD* magazine
- 15 woodworking forums covering finishing to tool buying to dust collection
- 11 forums with buying advice for specific types of tools
- Listing of woodworking clubs in the U.S. and Canada
- Tours of all five of our our Idea Shops
- **FREE** monthly downloadable plan
- Monthly tool sweepstakes
- **FREE** plans for shop jigs and organizers
- Shop tip of the day

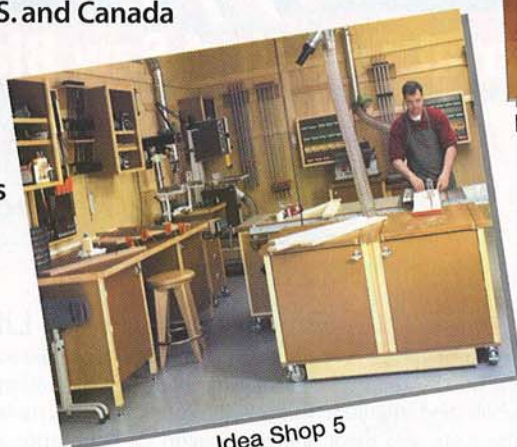

Idea Shop 5



Free downloadable plan each month

WOOD Store®

www.woodmagazine.com/store

Like what you see in *WOOD* magazine? Visit the *WOOD* store for additional plans, publications, and other products from the editors of *WOOD* magazine.

- 350+ easily searched, downloadable plans and techniques
- 100+ large-format paper woodworking plans
- Back issues of *WOOD* magazine (hurry, these are going fast)
- Shop tip books with hundreds of woodworking pointers
- Downloadable tool reviews
- Discounted prices on selected plans

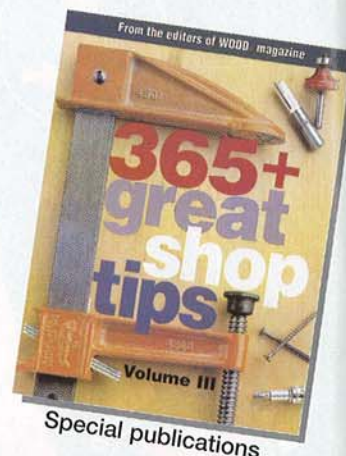

Special publications

Chair and footstool plan



WOOD[®] Online

WOOD Mall www.woodmall.com

With over two dozen merchants and 50,000 products to choose from, the WOOD Mall is the Internet's largest source of woodworking tools and supplies. Open 24 hours a day, 7 days a week for your shopping convenience, the WOOD Mall enables you to view thousands of products in the comfort of your own home. Tour this online woodworking megastore for these features:

- Power and hand tools
- Exotic and domestic lumber
- Woodworking plans
- Discounted tools and supplies
- Tool charts from past issues of *WOOD* magazine
- Search feature to scan all the stores within the mall
- Product index to find tools by categories

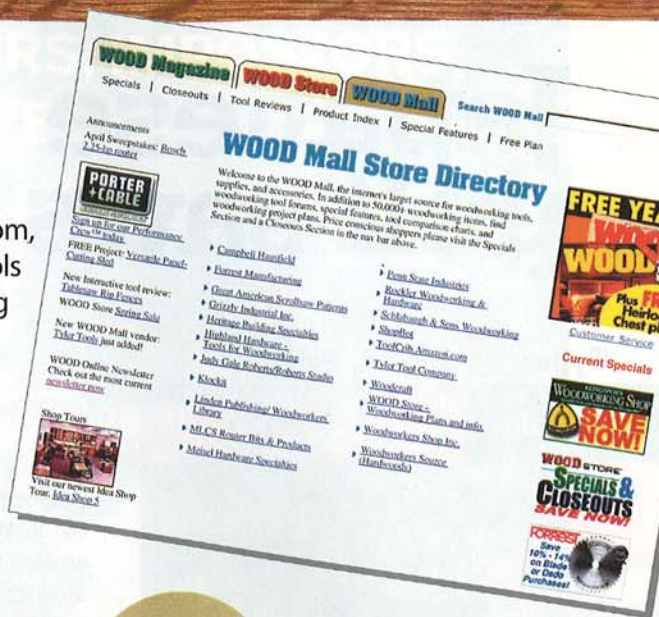

WOOD Online Newsletter www.woodmagazine.com/newsletter

Published online twice a month, our **FREE** woodworking newsletter is distributed to more than 75,000 woodworkers hungry for even more woodworking information. Register now, and we'll supply you **FREE** of charge the following:

- Updates on our latest free downloadable project plan
- Eligibility for our monthly tool sweepstakes
- What's new at *WOOD* magazine
- Free shop helper project in each issue
- Profiles of woodworking woods
- Special offers from our sponsors

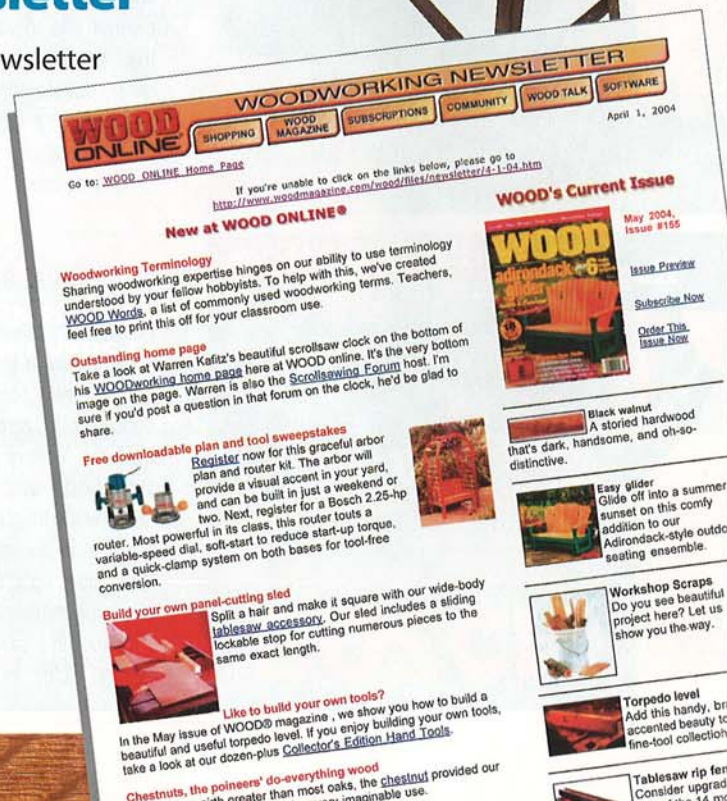

our editors test

Japanese pull saws

Why buy?

Unlike Western-style handsaws—the style most of us grew up with—a Japanese handsaw cuts on the pull stroke instead of the push. That makes the saw accurate (it's easier to pull a blade straight than to push it) and efficient (the thin blade removes less material). It also allows the manufacturers to harden the cutting teeth more than on a Western-style saw (whose teeth must be softer to withstand the impact of a "catch"), meaning they stay sharp longer. When the saw gets dull, simply replace the blade. We find three styles of pull saws most useful to woodworkers: For crosscuts, *dozuki* (doh-ZOO-kee) saws sport a stiffener to keep their super-thin blades from buckling during the return stroke; the slightly thicker blades of double-edged *ryoba* (ree-OH-buh) saws have fine crosscut teeth on one edge and coarser ripping teeth on the other; and the teeth of a *kugihiki* (koo-gee-HEE-kee) saw cut flush to the adjacent workpiece without marring it.

Type Brand, Price

Dozuki Rockler Dozuki Dovetail Saw, \$42



Editor test-drive:

This saw features a fine 25-teeth-per-inch (tpi) pitch, and produces a pencil-thin kerf (less than 1/64" thick). With its rigid back, it tracks true, although the stiffener limits the depth of cut to about 2". (When crosscutting, though, I doubled that capacity by cutting 1/4" deep on all four sides of a thick workpiece, as if defining the shoulders of a tenon, then completed with full-depth cuts.)

I hand-cut a few drawer dovetails using the Rockler Dozuki Dovetail Saw and it easily

stayed on my layout lines, even cutting diagonal to the grain without wandering. When used to fine-tune the fit of some interior millwork, this saw excelled in both crosscutting and ripping. And I found I could cut close-fitting notches in the molding more accurately—and in less time—than I could using my power jigsaw.

—Tested by David Stone, Features Editor

To learn more:
800/279-4441, rockler.com

Ryoba Japan Woodworker 19.605.0, \$26



Editor test-drive:

I've used Japanese-style saws for many years, and frankly, wouldn't own any other kind of handsaw. This ryoba was extremely sharp out of the box and, using the 17-teeth-per-inch cross-cut edge, I crosscut a slab of 3/4x4" hard maple cleaner and in about one-fourth fewer strokes than with a fine-tooth miterbox saw. And, cutting on the pull stroke, I found it much easier to accurately start the cut with the ryoba. Likewise with using the 8-tpi rip edge: faster, cleaner, and more accurate.

The handle on the Japan Woodworker ryoba pivots where it joins the blade so you can swing it to a more comfortable working position if you like, or use the saw in a tight spot. Even if you used only the crosscut edge, this saw would be well worth its \$26 price; the rip edge is just icing on the cake. A razor-sharp replacement blade costs only \$15.

—Tested by Kevin Boyle, Senior Design Editor

To learn more:
800/537-7820, thejapanwoodworker.com

Kugihiki Veritas Double-Edge Flush Saw, \$17



Editor test-drive:

I confess that I've had little luck when using the kugihiki saw in the *WOOD*® magazine shop. In fact, I'd pretty much written off the "no-marring" concept of a zero-set saw as overrated until I tried the Veritas Double-Edge Flush Saw. Its stiffer blade resists distorting during the cut, but still flexes enough to press flat against the workpiece. And the top-set teeth (the blade warns: "this side up") cut aggressively to prevent binding—another problem with other flush saws.

To test this saw, I drilled and dowel-plugged several holes in easy-to-scratch obeche ply-

wood. I quickly trimmed a dozen dowels without marring the surrounding surface. Impressed, I pulled a piece of polyurethane-finished red oak from my scrap bin and repeated the test, again without leaving so much as a scratch in the finish. This saw cuts equally well left- or right-handed and far exceeded my expectations. And although its blade isn't removable, the low price makes it easy to replace the whole saw.

—Tested by Jan Svec, Projects Editor

To learn more:
800/871-8158, leevalley.com

WANNABES, PRETENDERS, IMPOSTORS, TAKE NOTE.

**ONE TOUCH™
BLADE CHANGE**
*Easy lever-action
blade ejection
and fastest
click-in-place
insertion*

**TOOL-LESS
FOOT BEVEL**
*Quick, accurate,
one-hand bevel
adjustment
up to 45 degrees
without a wrench*

**PRECISION
CONTROL™
BLADE GUIDE**
*Blade cradle hugs
blade for 50% greater
accuracy and prevents
blade wandering
and bending*



**ONE TOUCH™ BLADE CHANGE FOR SIMPLE INSERTION AND EJECTION.
EXCLUSIVE PRECISION CONTROL™ DELIVERS 50% GREATER ACCURACY.**

Grab the Bosch 1590 – the next generation of the world's finest jigsaw. Feel for yourself the bold new performance standards it sets. With our new Precision Control Blade Guide, One Touch Blade Change, Tool-Less foot bevel, and the most powerful jigsaw motor on the market at 6.4 amps, you'll easily gain greater control over every cut your work demands.

Pull the trigger, there is no comparison. Look for the Bosch Precision Control nameplate at retail home centers, local distributors or online at boschtools.com.

sanding-drum dust collector

Looking to add even more functionality to the add-on drill-press table featured on page 52? Consider this integral dust-collecting system that channels fine dust to a vacuum hose during sanding-drum operations.

Whether you add sanding-drum dust collection to the add-on drill-press table in this issue, or to some other table, here's the lowdown on how to do it. Before applying the finish and installing the mini-track, lay out a 2½"-wide stopped channel that intersects the 3½"x3½" cutout in the table, where shown on the drawing, *below*. (Lay out the channel to the right or left of the center cutout, depending on the most convenient location for your shop vacuum.) Then adhere scrapwood guides to the table with double-faced tape, aligning them with the layout lines. Now rout a ⅝"-deep channel, as shown at *middle right*.

Note: If your table doesn't have a cutout and insert, drill ⅜" corner holes, and jig-saw a cutout. Then rout a ⅜" rabbet ¼" deep around its edges for a ¼"-thick insert.

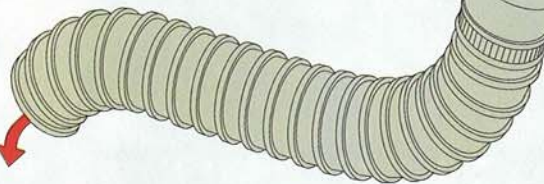

Change to a ⅜" rabbeting bit, and rout a ⅛"-deep rabbet along the edges of the center cutout and the channel, as shown at *bottom right*. Stop the rabbet where dimensioned on the drawing, *below*. Cut two ⅛" hardboard covers to fit the rabbeted openings, and glue and clamp them in place. Apply a finish, and install the mini-track. Using the holes in the shop-vacuum dust port as guides, drill screw holes, and fasten it in place. 🌲

Source

Dust port. Plastic shop vacuum dust port no. 03J61.10, \$2.15. Lee Valley Tools Ltd. Call 800/871-8158 or go to leevalley.com.

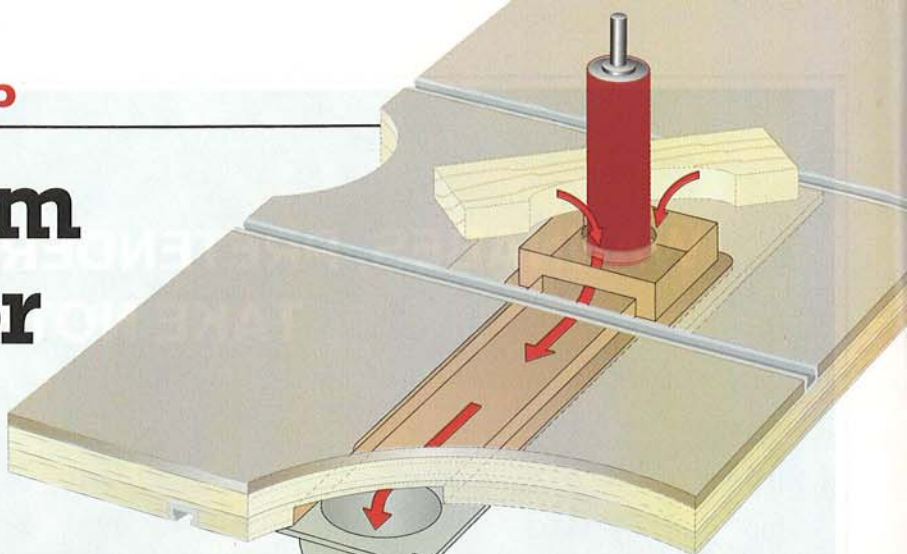

ROUTING THE CHANNEL

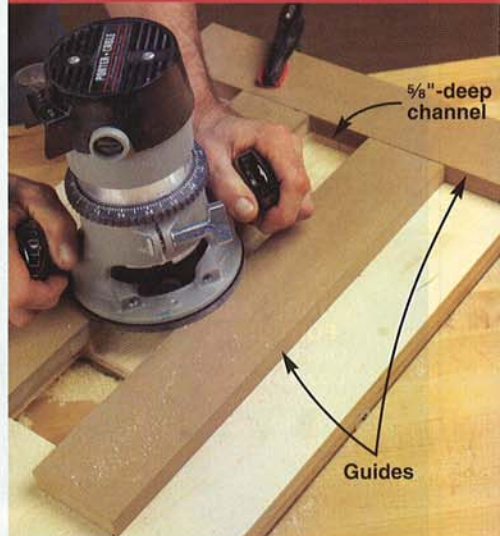

Using a pattern bit guided by scrapwood guides, rout a 2½"-wide stopped channel ⅝" deep in the bottom of the table.

ROUTING THE RABBET



Rout a ⅜" rabbet ⅛" deep along the edges of the 3½"x3½" cutout and the edges of the 2½"-wide channel, stopping 3" from its end.

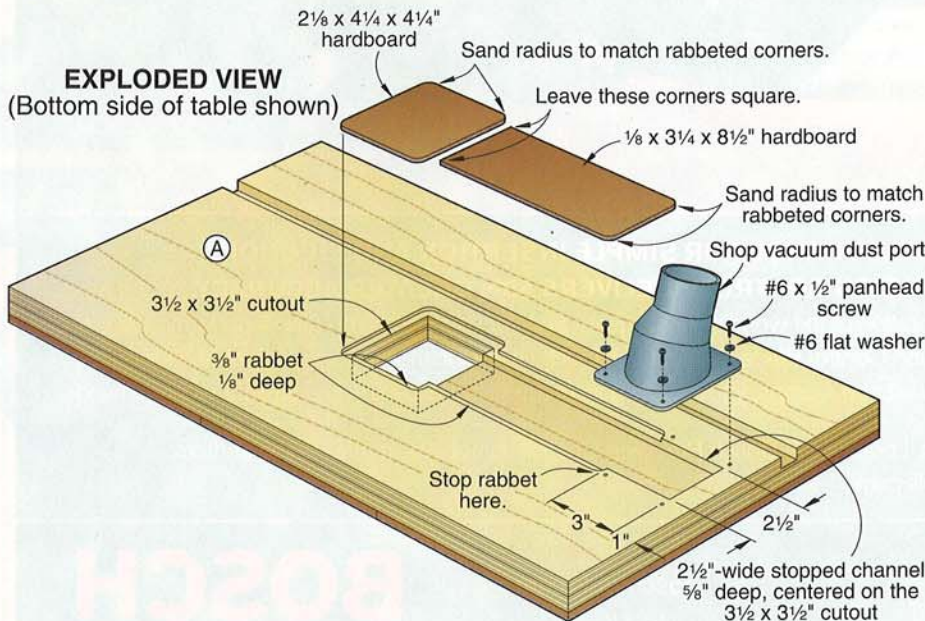

More power. More torque. More jealousy on the job site.

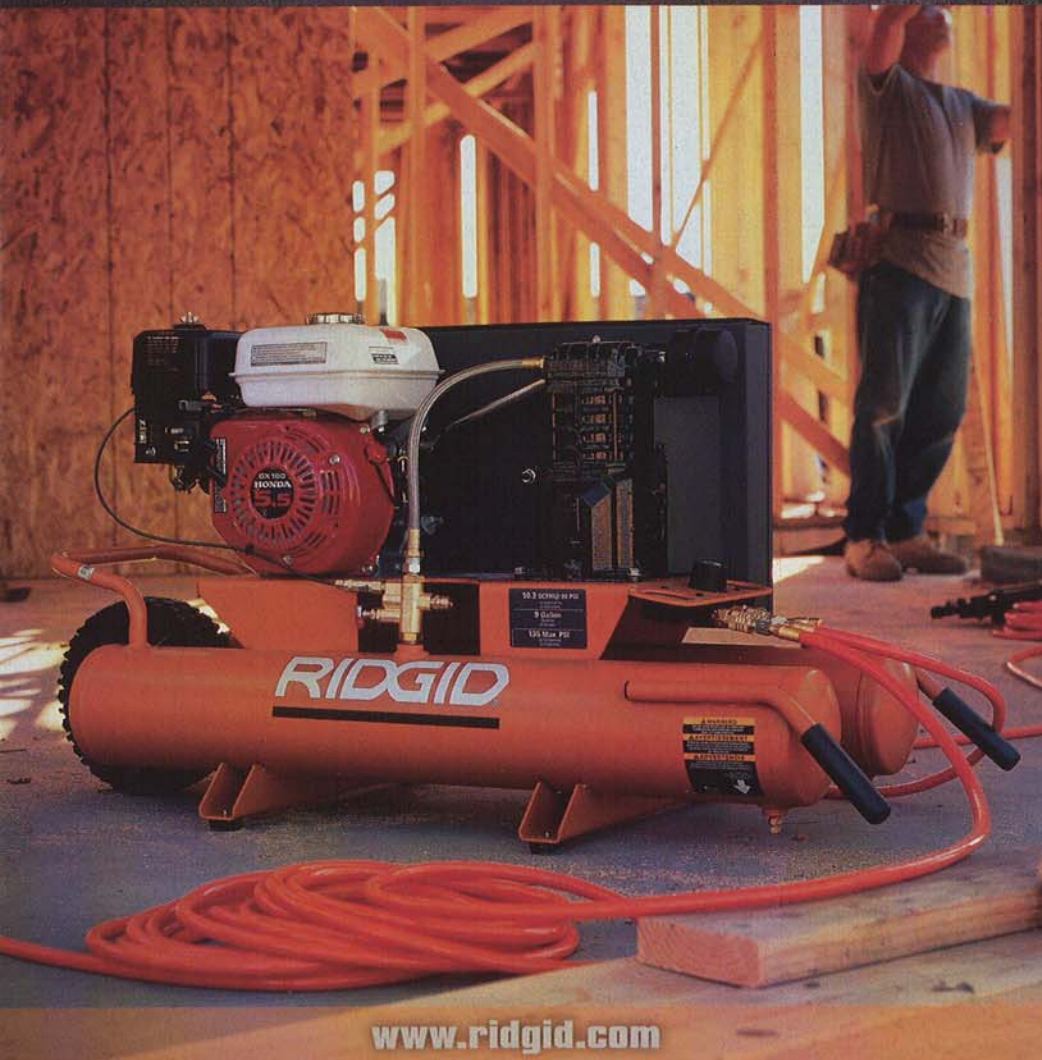

www.ridgid.com

You'll work smarter and more efficiently with RIDGID® heavy-duty tools that are heavy up on the features pros want. Like Exactline™ laser precision. Batteries that charge in half the time. And a wheelbarrow air compressor with more tank capacity, which means more productivity. RIDGID tools do things other tools can't. So you can do things other pros can't.

RIDGID

Powerful. Durable. Professional.



Available at The Home Depot.®

© 2004, RIDGID, INC. All Rights Reserved.

short cuts

News and notes from the woodworking world

A hull of a workshop

Just because you live on water doesn't mean you can't work with wood. Simply ask Ron Moreland. His home—a 24×55' houseboat—floats on the tidal waters of the San Francisco Bay in Sausalito, California. After retiring two years ago, Ron built a compact workshop in a 9×15' unfinished bedroom in the boat's hull, placing the shop under water, so to speak. "I found workshop books of little value since none of them dealt with an area this small," claims Ron. "Other than the jointer, I found I was able to put everything in the shop. Each tool has its place and must be put back before using the next one." By "everything" Ron means a table saw, a full complement of benchtop power tools, and a total-shop dust-collection system.



Within the depths of this houseboat lies a fully functional workshop where Ron Moreland builds china cabinets, chests of drawers, and dining tables.

When wood pulp (almost) ruled the seas

Here's a little-known history lesson from the annals of World War II. Frustrated with the U-boat threat to shipping, Great Britain, under the leadership of Winston Churchill, gave the initial OK to develop a giant unsinkable 2,000'-long aircraft carrier made from ice and wood pulp. Pykrete, the brainchild of Geoffrey Pyke, was a material that could be hammered and sawn and took forever to melt. Because it consisted of 90 percent frozen water, it resisted sinking if hit. And it patched easily, since the ship—slated to be called the HMS Habbakuk—would be

constructed of some 280,000 easily replaceable Pykrete cubes.

Naturally, it would be a cold-water ship, made in Canada by 8,000 workers. Plans called for a hollowed-out interior featuring crew quarters, hangars, and a huge refrigeration plant with 50'-thick walls. Propelling the Habbakuk at a top speed of 10 knots: 26 electric engines powered by a central generating plant. However, the U-boat threat declined due to anti-submarine warfare breakthroughs and codebreaking, melting away any interest in the costly "berg-ship."

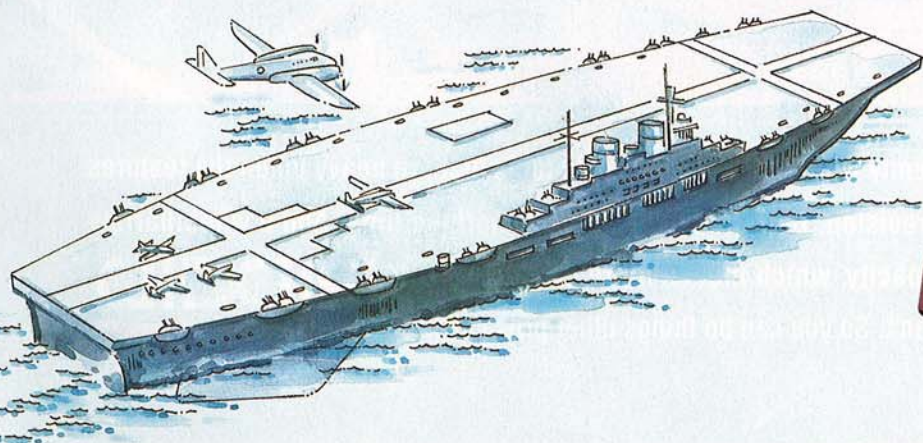

An unsinkable giant aircraft carrier made of ice and wood pulp was once on the planning table to become the pride of the British navy during World War II.

A bit of a stretch

Ever cut a project part too short or worked hard trying to eke the most from every board foot of some precious hardwood? Of course! It's happened to all of us. Here's how Rod Siminski of Lafayette, Indiana, solved the short-board dilemma. He calls it his "wood stretcher." OK, so it doesn't really work, but it sure looks like it does. Says Rod, "All my woodworking buddies stare at it and conclude, 'I've been looking for one of those.'"

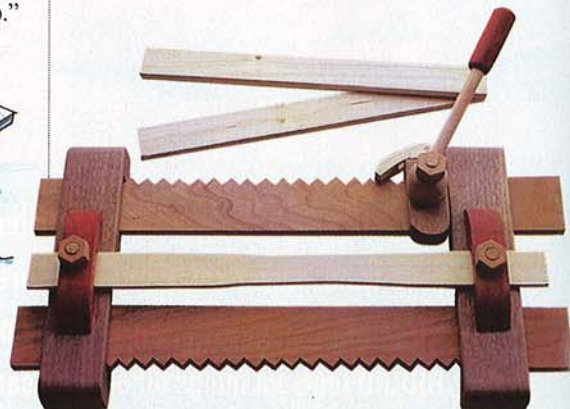

Rod Siminski's ratcheting wood stretcher seldom fails to draw a smile from onlookers. Measuring 18" long, it's made of pine, cherry, walnut, padauk, and maple.

Continued on page 20

Flawless finishes at an unbeatable price.



The **FEIN 6" Random Orbit Sander** can reduce your sanding time up to 30%. And dust-free sanding eliminates 90% of the clean-up.

The **FEIN Turbo II Dust Extractor** is the ideal companion for Fein dust-free sanders. Designed for heavy, continuous use, the Turbo II can handle power tools with inputs of 40 to 2000 watts (.3 to 19 amps). The vac can be used wet or dry for easy clean-up.

Innovation is standard equipment

For a free brochure and a dealer near you
call **1-800-441-9878**
or visit us on the web at www.feinus.com

Fein



Test your workshop smarts

Between projects and looking for some stimulation? Ply your woodworking IQ on these cerebral challenges. For the answers, see the next Short Cuts in *WOOD*® magazine, or go online right now to woodmagazine.com/editorial.

■ For what major workshop tool can we thank the Shakers?

■ What clear woodworking finish among oil or film-forming products holds up best in direct sunlight?

■ Name the wood that for centuries has been the preferred species of violin bow makers.

Answers to the questions in issue 155:

■ Can you name five woodworking tools that hail from the Stone Age?

The knife, chisel, auger, adze, and axe (shown below) were all there at the dawn of woodworking. Unfortunately for those early craftsmen, it wasn't until thousands of years later that *WOOD*® magazine arrived on the scene.

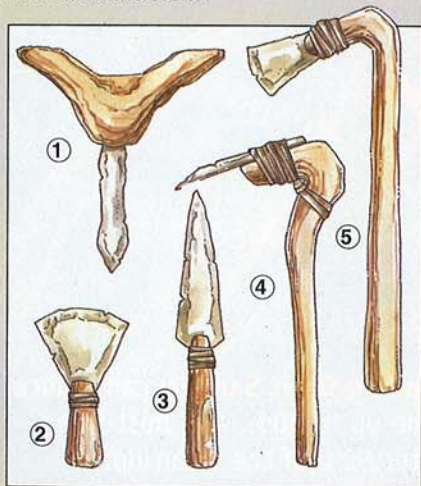

The auger (1), chisel (2), knife (3), adze (4), and axe (5).

■ What's the more common term for the woodworking process known as pyrography?

Woodburning. More precisely, the term pyrography derives from the Greek words *pur* (meaning fire) and *graphos* (meaning writing). Regardless of the name, the artistic process dates back to 17th-century Europe when small woodenware items,

and later furniture, were decorated with fire-heated iron tips. In creative hands the end results can prove quite impressive.



Today, woodburning artists use electrically heated pens and a variety of interchangeable tips to create designs.

■ How do you figure the length for a bandsaw that doesn't have a blade to measure from?

If you lost your bandsaw owner's manual and don't have a blade to measure from, or if you've added riser blocks, put this simple math formula to work to determine your tool's blade length:

$$\text{Blade length} = (2 \times A) + (3.14 \times B)$$

Key:

A = distance in inches between bandsaw wheel centers when the upper wheel is midway in its adjustment range

B = bandsaw wheel diameter

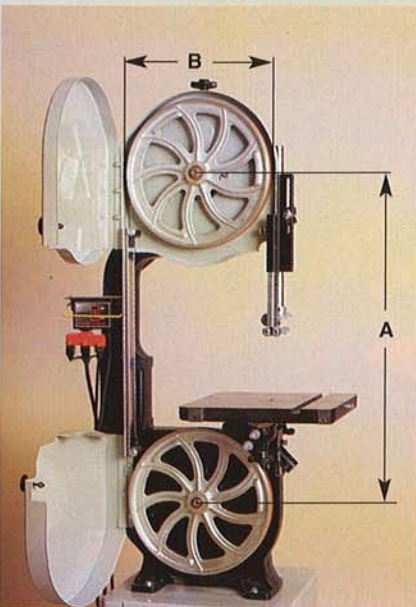

Woodturners, mark your calendars

On June 10–12, 2004, the Utah Woodturning Symposium will celebrate its 25th anniversary at Brigham Young University in Provo. Its biggest event ever, the UWS plans to include more than 100 demonstrations by world-class turners and an exhibition of work that represents 130 turners from 12 countries. To learn more or register for a workshop, visit utahwoodturning.com, or call 801/422-2021.

Buy a tool, get a free education...and plans

Here's a heads-up that woodworkers of all skill levels will like. From June 1 through July 31 of this year, Delta Machinery will run a special promotion for buyers of its tools at Lowe's home centers. With the purchase of any Delta machine, you can buy the new Do-It-Yourself Woodworking Kit for \$19.95, then mail in the tool's rebate and be reimbursed for the Kit's full amount. What is the "Kit"? It's a CD jam-packed with 15 quality project plans from *WOOD*® magazine, and loads of tips and techniques by TV's master woodworker Scott Phillips.

In his presentation, Scott works through the machining operations, tune-ups, and safe use of six major workshop machines: the tablesaw, bandsaw, drill press, thickness planer, jointer, and compound mitersaw. He tops that with the step-by-step construction of a Shaker-style bookcase from the March 2004 issue of *WOOD*.

In addition, you'll receive printable drill and screw charts and articles on shop layout, dust-collection, finishing, and more. What if you don't buy a Delta machine? No problem. You can still get the CD for an unrebated \$19.95.



TV's master craftsman Scott Phillips and *WOOD* magazine Editor-in-Chief Bill Krier pause for a photo during the taping of Delta's new Do-It-Yourself Woodworking Kit.



GRIZZLY PRESENTS

THE BEST 14" BANDSAW ON THE MARKET - PERIOD!

We have redefined what a 14" bandsaw should be like and have incorporated features into this saw that normally are either optional or unavailable on other bandsaws on the market. **CHECK IT OUT!**



HINGED DOOR COVERS

QUICK BLADE CHANGE LEVER ON BACK

DELUXE HEAVY-DUTY FENCE INCLUDED

UPPER & LOWER BALL BEARING GUIDES INCLUDED!

PRECISION GROUND CAST IRON TABLE

OTHER FEATURES:

- POWERFUL 1 HP 110/220V MOTOR
- FASTEST BLADE CHANGE IN THE INDUSTRY
- TAKES STANDARD 92½" BLADES FROM ¼" TO ¾"
- MAX. CUTTING HEIGHT: 6"
- SOLID CAST IRON CONSTRUCTION
- FULLY BALANCED WHEELS FOR SMOOTH RUNNING
- INCLUDES 4" DUST PORT
- INCLUDES MITER GAUGE
- INCLUDES ⅜" BLADE
- APPROX. SHIPPING WEIGHT: 210 LBS.



CLOSE UP OF FENCE SYSTEM

POWDER COATED PAINT FOR DURABILITY & SHARP LOOKS!

2 SPEEDS

Circle No. 0583

VISUALLY APPEALING STAND WITH STRUCTURAL BRACKETS THAT DOUBLE AS SHELF BRACKETS

MODEL G0555

INTRODUCTORY PRICE

\$375⁰⁰

\$55 Shipping
ANYWHERE IN LOWER 48 STATES

OPTIONAL ITEM:

H3051 RISER BLOCK KIT
RAISES CUTTING HEIGHT TO 12".
INCLUDES BLOCK, MOUNTING HARDWARE, BLADE & EXTENDED BLADE GUARD.

\$49.95

AN UNSOLICITED CUSTOMER TESTIMONIAL:

"I received my G0555 bandsaw yesterday and set it up today. I cannot believe the quality of this machine! It far surpasses anything I've seen and I think I've seen them all. It operated perfectly right from the start with almost no adjustment. How can you sell this complete machine so low? I wish I was 35 years old instead of almost 73 as this machine is built to last a lifetime. You sure outdid yourself!

P.S. The set-up, operation and fine tune manual was about the best I've ever seen. I was delighted. It cuts smoothly, quietly and perfectly. Keep up the great work."

Robert W. Loewen
Colorado Springs, CO

Grizzly Industrial

There is absolutely no other company in the world that has a larger selection of bandsaws than Grizzly. We know bandsaws inside-out and our numerous years of selling bandsaws has culminated in this incredible 14" saw shown above. You will not be disappointed!

4981R

grizzly.com

CUSTOMER SERVICE: (570) 546-9663 • FAX: 1-800-438-5901

1-800-523-4777

- 2 Overseas quality control offices staffed with qualified Grizzly engineers.
- Most orders shipped within 24 hours.

- 24 Hour ordering by phone or online
- Our huge parts department is stocked with over a million parts at all times.



MEDIA CODE
AD2192

3 SHOWROOM LOCATIONS: BELLINGHAM, WA • SPRINGFIELD, MO • MUNCY, PA

portable glue/paper towel center

Equally at home mounted on a wall or sitting on your workbench.



Wall Storage System

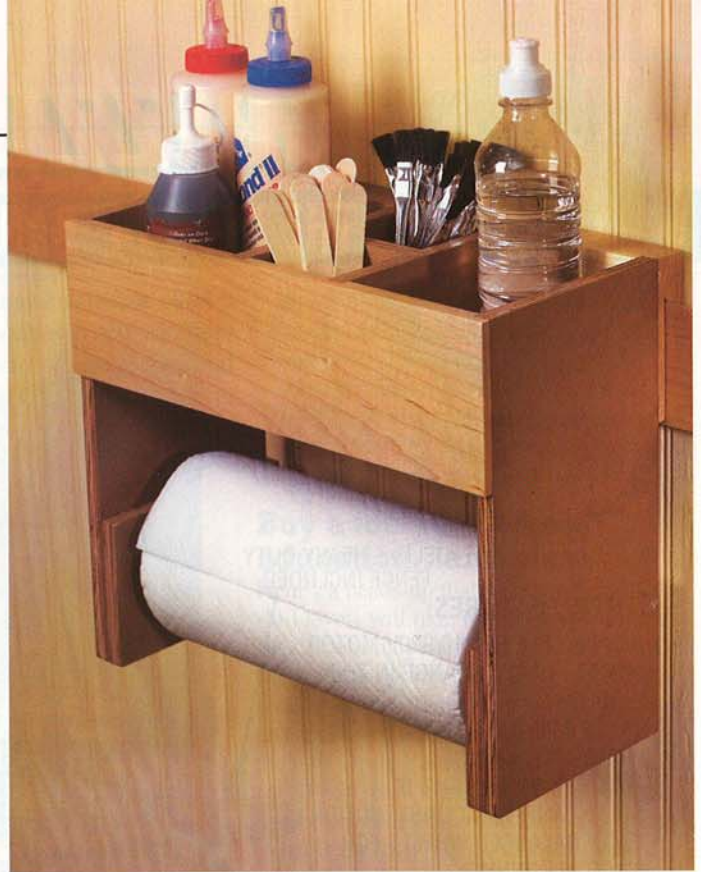

Hang this handy organizer on the Idea Shop 5 cleat system featured on page 86 of the November 2003 issue of *WOOD*® and quickly lift it off and move it wherever you work. It keeps your glue and glue clean-up supplies close at hand. For this shop aid, cut parts A–D from 1/2" plywood, part E from

1/4" hardboard, part F from 1/2" solid stock, and part G from 3/4" stock to the sizes noted on the drawing below. Cut the dowel groove in the supports (D) to shape. Cut the dados, rabbets, and grooves, where illustrated, in parts A, B, and F. Assemble the unit. Cut a 3/4" dowel to fit between the side pieces and into the dowel groove.

To hang the center in a shop without the cleat system, eliminate part G. For use with the Idea Shop 5 cleat system, screw the cleat to the back F with the top edges of F and G flush.

1a CLEAT DETAIL

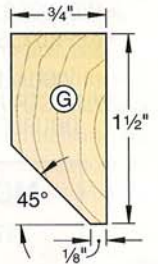

See more of the Idea Shop 5 wall storage system at woodmagazine.com/IS5

1 EXPLODED VIEW

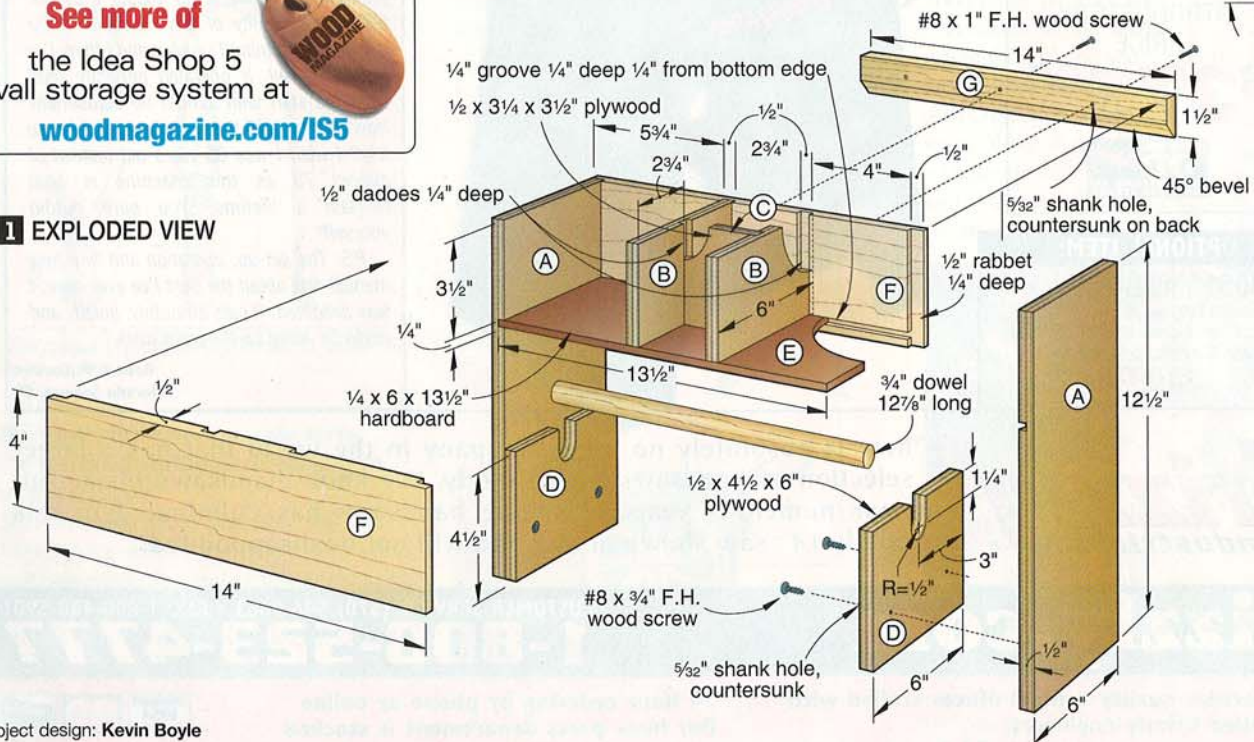

Project design: Kevin Boyle



“Benjamin Moore
calls it
Meadow View.”

I call it a
dream
come true.”

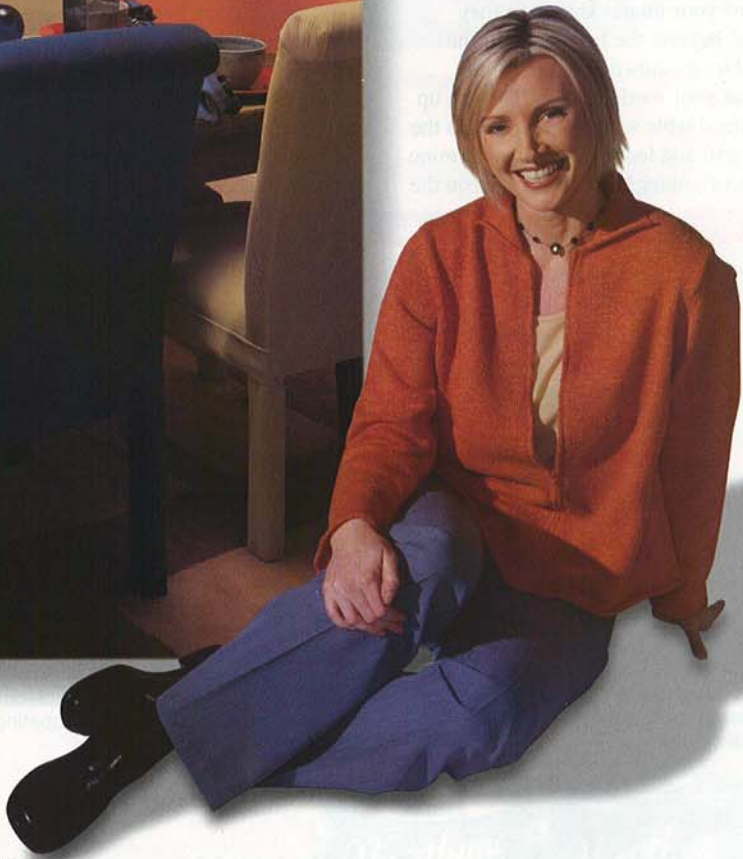

I had this color in my head. A color so exciting, so inviting, it would be irresistible. To make my vision a reality, I went to my Benjamin Moore® retailer, the only place you can find Benjamin Moore® paint. He listened to my ideas, then gave me some great tips, and I

found it really easy to pull the whole room together. With Benjamin Moore® paint I get quality results every time. And whether I do the painting myself, or have someone do it for me, it gives me the confidence to create a room that expresses the real me. I can't wait to start dreaming about the rest of the house.



We make it simple. You make it beautiful.™

For a retailer near you call 1-800-6-PAINT-6 or visit www.benjaminmoore.com

©2003 Benjamin Moore & Co. AquaVelvet, Benjamin Moore, crown device and Regal are registered trademarks, and the triangle M symbol and We make it simple. You make it beautiful. are trademarks, licensed to Benjamin Moore & Co.

How to cut rabbets on a jointer

Q: I have a 6" jointer with a rabbeting ledge, but I don't understand how to use it to make rabbets. What's the proper method?

—Stephen Vallery, Yardville, N.J.

A: You can make perfect rabbets on your jointer, Stephen, as soon as you take care of a couple of set-up details. First, adjust your jointer knives so they extend $\frac{1}{32}$ " beyond the front edge of the outfeed table, as shown in **Step 1**; this ensures that your workpiece won't hang up on the outfeed table while sliding across the rabbeting arm and ledge. Second, determine whether your jointer has a depth stop on the

infeed table that limits cuts to $\frac{1}{8}$ " or less. Most rabbets are deeper than that, so check your owner's manual for information about overriding the depth stop. Many jointers have a spring-loaded pin on the right side. Pull out on the pin to disengage it as you lower the infeed table beyond the normal limit. The rabbeting ledge serves as the maximum stop at a depth of about $\frac{1}{2}$ ".

To make a rabbet, remove the guard so that it doesn't interfere with the workpiece. *Note: Removal of this guard calls for extra caution during the rabbeting operation.* Set your jointer fence to establish either the width of the rabbet (if you plan to place the workpiece facedown on the jointer, as

shown in **Step 2**) or its depth (with the workpiece on edge, as shown in **Step 3**). A workpiece held on edge rides solely on the infeed and outfeed tables. Laid on its face, it receives extra support from the rabbeting arm, so choose this position when possible. As indicated on the drawings, tear-out is most likely on the surface cut by the ends of the jointer knives.

Finally, adjust the infeed table for a light cut (approximately $\frac{1}{8}$ " for hardwoods and $\frac{1}{4}$ " for softwoods), place the workpiece on the infeed table, and make the first pass. Form the rabbet with a series of passes, lowering the infeed table each time and disengaging the depth stop when necessary.

3 QUICK STEPS TO JOINTER-MADE RABBETS

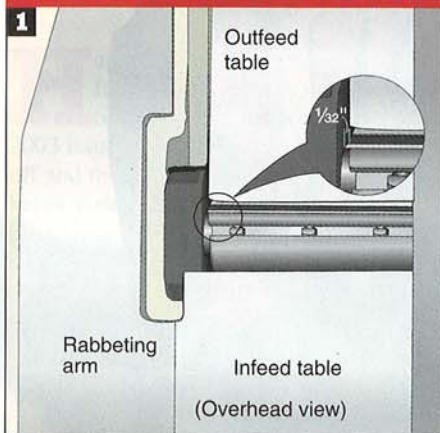

1 For smooth rabbeting results, set all of your jointer knives so they project $\frac{1}{32}$ " beyond the outfeed table.

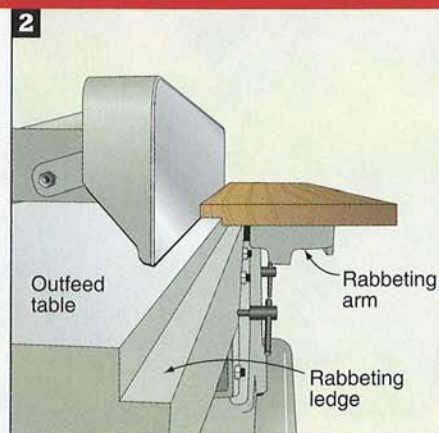

2 To make a rabbet, hold your workpiece flat on the jointer when possible. The rabbeting arm adds valuable support.

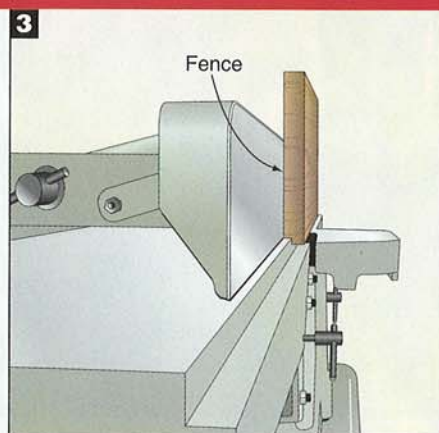

3 Choose a vertical orientation if you need to avoid tear-out on the workpiece face, created as the knife ends scrape the stock.

Starting a finish with tung oil spells trouble

Q: To finish a solid cherry tabletop, I applied a coat of pure tung oil, let it dry for a day, and then followed with several coats of high-quality water-base. Three days after the final coat went on, white patches began to appear in the finish. What went wrong?

—Tom Lendway, Vadnais Heights, Minn.

A: Tom, your problem stems from the tung oil, which needs to cure for several days before it's ready for a topcoat. For that reason, Steve Mickley, host of the

woodmagazine.com finishing forum, strongly recommends using boiled linseed oil rather than tung oil when you want to accentuate figure before applying a topcoat. After applying boiled linseed oil, and with temperatures of at least 65 degrees F and average indoor humidity, Steve suggests waiting a week before topcoating with varnish, lacquer, polyurethane, or shellac. Lengthen your wait to 10 days before applying a water-based topcoat.

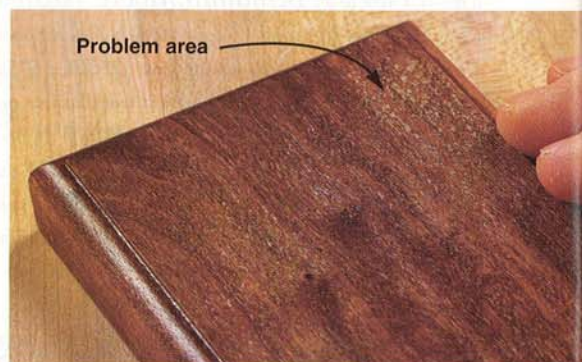

If you apply oil to bare wood and follow too soon with a water-based topcoat, white spots begin to appear within a few days. To repair this situation, strip or sand the piece and start over.

Continued on page 26



REMOVE FURNITURE.

REFINISH YOUR OWN FLOOR.

BASK IN THE BEAUTY OF YOUR WOOD'S RICHNESS.

PUT FURNITURE BACK. (OPTIONAL)

Varathane®



Take pride in a job well done when you refinish your floors with Varathane.

Varathane is the premium polyurethane created to give your wood floors new luster and durability. It's formulated specifically to prevent scuffs and scratches better than the competition, making it the perfect way to

complete your do-it-yourself floor-finishing project. Just look for the Varathane Floor Finishing Center at your local home center or hardware store, where you'll find everything you need to refinish your wood floors. Varathane— the premier name in wood care— Interior, Floors and Outdoor— for over forty years.

**FLOORS THIS BEAUTIFUL
HAVE NEVER BEEN SO EASY.**

STEVE WALL LUMBER CO.

Quality Hardwoods and Woodworking machinery For The Craftsman and Educational Institutions

Ash	4/4	Select	2.40	\$ 85.00
Basswood	4/4	Select	1.95	\$ 72.00
Birch	4/4	Select	2.75	\$ 89.00
Butternut	4/4	1C	2.30	\$ 77.00
Cherry	4/4	Select	4.90	\$110.00
Hickory - Pecan	4/4	Select	2.85	\$ 89.00
Mahogany (Genuine)	4/4	Select	3.90	\$100.00
Maple (Hard)	4/4	Select	3.15	\$ 96.00
Maple (Soft)	4/4	Select	2.30	\$ 79.00
Poplar	4/4	Select	1.75	\$ 72.00
Red Oak	4/4	Select	2.50	\$ 88.00
Walnut	4/4	Select	4.00	\$100.00
White Oak	4/4	Select	2.50	\$ 88.00
Cedar (Aromatic Red)	4/4	1C+Btr.	1.80	\$ 72.00
Cypress	4/4	Select	2.40	\$ 80.00
White Pine	4/4	F.G.	1.20	\$ 62.00
Yellow Pine	4/4	Clear	2.00	\$ 74.00

Above prices are for 100' quantities of kilndried rough lumber sold by the Bd. Ft. FOB Mayodan, NC. Call for quantity discounts. Other sizes and grades available.

Above prices are 20 bd. ft. bundles of clear kilndried lumber 3"-10" wide • 3'-7" long (Random widths & lengths) Surfaced 2 sides or rough. Delivered UPS prepaid in the Continental U.S.

SEE OUR CATALOG ON THE WEB!

UPS
Specials

NOW AVAILABLE

Custom Made
Raised Panel
Cabinet Doors

4/4 Log Run
Walnut
100 bd. ft. \$160

Also Available
Exotic Lumber

STEVE H. WALL
LUMBER CO.

BOX 287
MAYODAN, N.C. 27027
336-427-0637
1-800-633-4062
FAX 336-427-7588

Email: wood@walllumber.com
Website: www.walllumber.com

Send \$1.00 For Lumber Catalog
Prices Subject to Change Without Notice

Circle No. 856

WANT THIS?



A clean, sharp hole every time. No chips, no splits, no errors. It takes skill and a sharp drill bit. And that takes the **Drill Doctor®** drill bit sharpener.

GET THIS.

- Restores bits to factory sharp
- Fast and easy to use
- Sharpens most twist bits—even split point
- Diamond sharpening wheel
- Powerful 20,000 rpm motor

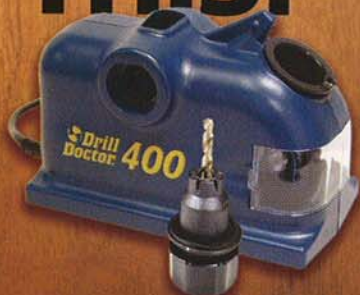

Drill Doctor®
The Drill Bit Sharpener

Drill bits are meant to be sharpened

www.DrillDoctor.com • 1-888-MYDRILL

"I have never recommended a product that was so easy to use and so effective. This is one of the best tools I've ever purchased."

—Stephen Bierhorst
Patterson, Louisiana

Available at Home Depot, Lowe's, Sears and wherever fine tools are sold

Circle No. 1511

ask wood

Oil-based stain is OK under a water-based topcoat

Q: Will I have problems if I apply a water-based topcoat over an oil-based stain? How about an oil-based finish over water-based stain?

—Bill McTaggart, California City, Calif.

A: No problem in either case, Bill, as long as you allow the stain to dry thoroughly. Wait as recommended on the stain and topcoat containers and then put your face next to the surface and sniff. If you smell the stain, give it more time.

Whether you start with oil- or water-based stain, switching to the other type of topcoat actually helps avoid trouble. If you brush or wipe on a topcoat that contains the same solvent as the stain, you might dissolve the stain and cause smearing.



Check the stain and topcoat containers for guidelines about waiting times. The label of this product recommends waiting 48 hours after applying an oil-based stain.

Got a question?

If you're looking for an answer to a woodworking question, write to Ask WOOD, 1716 Locust St., GA-310, Des Moines, IA 50309-3023 or send us an e-mail at askwood@mdp.com. For immediate feedback from your fellow woodworkers, post your question on one of our woodworking forums at woodmagazine.com.



More Accurate than Einstein's Theory

The classic watch built with German precision to 1 billionth of a second

There is a new super-accurate government device that gives you a perfect use for atomic theory. The US government has engineered the most ingenious, most accurate clock in the world, the new F-1 U.S. Atomic Clock in Boulder, Colorado. Our extraordinary new Stauer EMC² watch uses this clock to report the exact time from this remarkable cesium fission clock. So you are on time...all the time. This amazing timepiece will gain or lose only one second over a twenty million-year period. It is that accurate!

This perfectly tuned technological invention is now available for UNDER \$100. And you'll never have to set this watch...the hands set themselves. Just push one of the buttons and you are synchronized with the F-1 and the hands of the watch move to the exact time position. The Stauer EMC² exceeds the accuracy of any Swiss luxury automatic so you can be more accurate and keep most of your money in your wallet... not on your wrist.

There are some unattractive plastic digital atomic watches on the market, but when our German movement maker made it possible for us to break the \$100 price barrier with a beautiful, classically styled stainless steel

analog watch, we were truly excited.

The EMC² features precise atomic time with an automatic Standard time and Daylight Saving Time adjustment. It will adjust for leap years and even leap seconds! A breakthrough in technology at a breakthrough price.

The large numeric markers are luminescent and extremely easy to read so the watch is perfect for low light situation. The EMC² is water-resistant to 5 atms as well. The small readout shows you the date and has a digital second counter. This watch is rugged enough to take to the gym but handsome enough to wear to the boardroom or out to dinner. The designers built this watch for those who prefer their watches to be practical and sharp-looking rather than overrated and overpriced.

How can it be so accurate? The new F-1 clock uses laser beams to measure the photons emitted from the cesium atom to measure the

resonance frequency. This laser-cooling clock makes it about 20 times more accurate than any other clock on earth.

This timepiece is a great gift for anyone who values precision and technology. Know precisely when the markets open and close. Know

the times for landings and take offs or when the train is leaving the station. If punctuality and accuracy matter, then this watch was built for you.

We're still perfecting Einstein's theory. We must apologize that our Stauer EMC² Atomic Watch loses 1 second every 20,000,000 years. Our scientists are working diligently to correct this problem; but in the interim if you are not thrilled with the design and the accuracy of the EMC², return it in the next 30 days for a full refund of the purchase price.

This watch is not available in stores and it comes with our 30 day money-back guarantee. If you're not completely satisfied with the accuracy, simply return the watch for the full purchase price.

Not Available in Stores

Call now to take advantage of this limited offer.

Stauer EMC² Analog Atomic Watch
Three EXACT Payments of \$33 +S&H

800-482-7995

Promotional Code AAW116-02

Please mention this when you call.
 To order by mail, please call for details.

The operation of atomic precision depends on an electrical oscillator regulated by the natural vibration frequencies of an atomic system (as a beam of cesium atoms) accuracy to about one second in 20 million years, making it the most accurate clock ever made

NEXTTEN 14101 Southcross Drive W.
 Dept. AAW116-02
 Burnsville, Minnesota 55337
products for your next ten years.

For fastest service, call toll-free 24 hours a day **800-482-7995**    

Visit us online at www.NextTen.com for the complete line of Stauer Watches, Jewelry and Collectibles

epoxy goes mainstream

While most woodworkers shy away from epoxy, furnituremaker Robert Hensarling finds it the adhesive of choice in his workshop, and for good reason.



Famed for his mesquite Texas-style rocking chairs (featured in issue 112 of *WOOD*® magazine), Robert Hensarling uses epoxy for just about all his assembly, regardless whether the furniture finds a home in a living or board room. What gives (or doesn't give) with epoxy? We asked Robert about his heavy reliance on it, seeking answers that you too can put to use in your shop.

Q: Why do you choose epoxy for your joinery?

A: I like it because it maintains a little resiliency after curing. In other words, it expands and contracts as wood moves. I work mostly with mesquite, but find that epoxy also performs well with other woods I work including quilted maple and black walnut. Another advantage: Compared to yellow glues, it gives me more working time (approximately 15 to 30 minutes) for adjustments before it sets up.

Q: What do you mix the epoxy in, and how do you apply it?

A: I mix the epoxy in throwaway plastic cups using wood sticks, such as paint stirrers and tongue depressors. To ensure that the depressors fully contact the cup side and bottom for thorough mixing, I square the round ends on a disc or belt sander. I apply the epoxy using the sticks and disposable glue brushes.

Q: Epoxy can be messy. How do you deal with squeeze-out?

A: I assemble everything rough, sanded with nothing finer than 60-grit paper. For a sculpted joint, such as between an arm and a leg, I let the epoxy cure

overnight. Then I remove the squeeze-out with a die grinder, carbide grinding wheel, or a drill with a 60- or 80-grit sanding drum, as shown in the photo, *below*. Because I leave $\frac{1}{16}$ " to $\frac{1}{8}$ " extra stock to remove on curved joints for blending purposes after assembly, using a grinder or sanding drum also helps to sculpt the area to final shape. After grinding, I finish-sand the area using a palm sander with progressively finer grits of sandpaper.

For a square-edge butt joint, I remove excess epoxy using a paper towel right after clamping the parts together. When the epoxy cures, I sand the area to remove any remaining adhesive. I don't use acetone or other solvents, which can seep in and weaken joints or clog open wood pores.

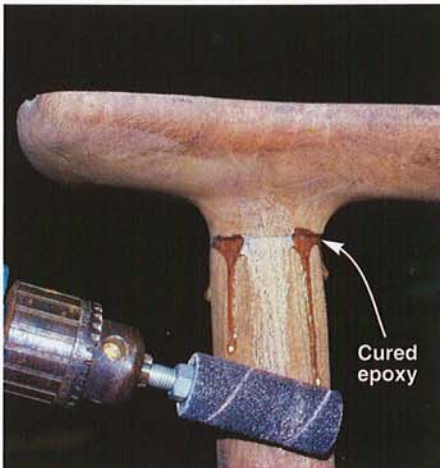

A drill with a sanding drum quickly removes excess cured epoxy and blends the joint between this arm and leg.

Q: What types of epoxies do you use for joinery?

A: For most joinery, I use System Three's General Purpose Epoxy. (Call 800/333-5514, or on the Web at systemthree.com.) It comes with a resin and a choice of three hardeners. In winter weather, I go with their fast hardener; at normal 60 degree to 100 degree temperatures, their medium hardener works well; on really hot Texas days, I use their slow hardener. Using the appropriate hardener gives me the needed open time to spread out, fine-adjust, and clamp joints.

Solvents and safety

Solvents for epoxy include acetone, lacquer thinner, denatured alcohol, and ordinary white vinegar. These work fine for cleaning tools, but not so well on skin because these thinners can permeate your pores. Robert always wears disposable latex gloves when he mixes, pours, dispenses, spreads, clamps, or cleans up epoxy. Also, work in a well-ventilated space or wear a respirator, he warns. Fumes from epoxies pose health hazards.

Continued on page 30

WE'VE TAKEN LEVELS TO A WHOLE NEW LEVEL.



The traditional level has served man well. But now there's the Laser Trac™ Level from Craftsman®. It guides you with a precise beam, which even goes around corners. So there's no need to mark up your walls. And you can quickly adjust the laser from horizontal to vertical. Get yours at Sears or Sears

SEARS
Good life. Great price.

Hardware Stores for \$39.99. Or
order online at craftsman.com.

CRAFTSMAN®

MAKES ANYTHING POSSIBLE®

For joints that I leave particularly loose, such as leg joints, I use System Three's T88 Structural Epoxy Adhesive instead of the General Purpose Epoxy because it's thicker and won't run out. (Because I test-fit these joints many times during construction, the loose fit reduces the chance of damaging the parts.) T88 epoxy comes with a resin and one hardener, and it cures in temperatures as low as 35 degrees.

Q: To fill gaps on surfaces, do you add sawdust to the epoxy?

A: I prefer not to do this, and here's why. I've found that the epoxy color

changes when you add sawdust, particularly with mesquite, which makes a repaired area more noticeable. I've tried adding tints to get a better color match, but found this unsatisfactory too. For me, using just the basic clear amber epoxy works best.

Q: How do you repair epoxied joints?
A: By knocking them apart?

A: You can't knock an epoxied joint apart as easily as one assembled with water-based glues. What I do instead when chair making is saw off a piece—say a back slat, flush at the seat and head crest. Then I drill out the joints, making the hole in the

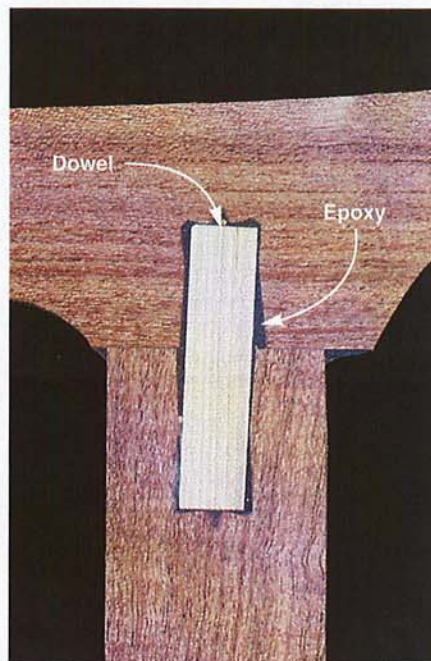

This arm/leg joint cutaway shows how the epoxy encapsulates the dowel in an over-size hole, strengthening the dowel.

head crest twice as deep as the one in the seat, and epoxy a new slat in place. This same technique works for replacing an arm or a leg, but you must be very careful when cutting out the broken part to avoid removing stock at the joint from the adjoining part.

Q: Do you prepare a joint for epoxy differently than for yellow glue?

A: Yes. One of the things I like about epoxy is that it lets me make what I call "floating dowel" joints. With these, I drill slightly over-size holes so the dowels have a loose fit. Epoxy fills the space around the dowels, as shown in the photo, above, which makes them stronger and lets me make adjustments when clamping the parts together. Another nice feature about epoxy is that it won't swell dowels or biscuits because there's no water in it. ♣

Robert offers four-day seminars on rocking-chair building as well as one-on-one instruction. For more information, write Robert Hensarling, 4326 East Main Street, Uvalde, TX 78801, or visit his Web site: mesquiterocker.com

The First to FINISH WINS!



Super-Fast Drying FORMULAS

If you want a quality finish and you want it fast, the name to look for is ZAR®.

ZAR Premium Quality Oil-Based Wood Stain provides rich uniform color in just 3-hours. This new fast-drying formula is available in 20 popular colors and a tint-base for custom colors.

ZAR ULTRA Fast Drying Polyurethane is an oil-based polyurethane which provides a beautiful

protective finish that will last in the toughest conditions. It dries and can be recoated in just 2-hours. Available in gloss, semi-gloss, satin and antique flat sheens for the look you want.

ZAR Wood Stain and Clear Finishes, the perfect choice for the fastest finish — Making you the winner.

ZAR®

The fastest way to a beautiful finish!

For a free brochure and dealer nearest you, call 1-800-272-3235 or visit www.ugl.com

Woodmaster®

4-WAY MONEY-MAKER

Molds • Planes • Sands • Saws



FREE 30-Day Trial!

Highest Profit: MAKE CURVED MOLDING!

500+ PATTERNS!

Now, turn a \$5.00 rough board into \$75.00 worth of high-dollar molding in just minutes. Make over 500 standard patterns, curved molding, tongue & groove, picture frame stock, any custom design. QUICKLY CONVERTS from Molder/Planer to Drum Sander or power-feed Multi-Blade Ripsaw. Made in U.S.A. 5-Year Warranty. Choose from 12", 18" or 25" models.

Circle No. 1818

Variable Feed Makes the Difference! Just a twist of the dial adjusts the Woodmaster from 70 to over 1,000 cuts per inch. Produces a glass-smooth finish on tricky grain patterns no other planer can handle. Plenty of American-made "muscle" to handle money-saving, "straight-from-the-sawmill" lumber. Ideal for high-value curved molding.

WOODMASTER OWNERS SAY IT BEST...

BEST VALUE
"After checking them all, Woodmaster was obviously the best deal for the money. Also, I would like to acknowledge the polite and prompt service."
- E.D. Holtz, North Carolina

RUNAWAY HOBBY
"Thanks to Woodmaster, what started as a hobby is now a full-time millwork business."
- D.A. Probst, Pennsylvania

FREE Catalog and Video!



Quick-Change Molding Head lets you create custom molding from any stock. Choose from over 500 standard trim and picture frame patterns...or design your own!



Commercial-Duty Thickness Planer features infinitely variable feed rate. Use higher speeds for fast stock removal... slow down to get over 1,000 cuts per inch for fine finish passes.



Power-Feed Drum Sander saves hours of tedious hand sanding. Speeds production, improves quality. No more waves or cross grain scratches.



New Ripsaw Attachment lets you gang rip with power feed in a fraction of the time it takes for hand-fed passes on an ordinary table saw.

Mail this coupon or **Call Today For FREE FACTS!**

1-800-821-6651

Ask for Extension P310



YES! Rush me my FREE Information Kit!

Name _____
Address _____
City _____
State _____
Zip _____

Woodmaster Tools
Dept. P310, 1431 N. Topping Avenue
Kansas City, MO 64120

put your best face forward

When you build with quartersawn oak, use these simple techniques to display as much beautiful figure as possible.

The distinctive ray flecks of quartersawn white oak play a key role in beautifying the mission tall clock on page 38. When making it, we took extra steps to show as much of that figure as possible—on adjacent faces, for instance. To work similar magic with your projects, try the three techniques here whenever you build with wood that bears beautiful figure on its faces but not on its edges.



For a solid leg with two adjacent show-piece faces, as shown at left, cut and assemble the four pieces you see below.

Make two display-worthy faces for each leg

The mission clock stands on legs that run full length. If we had laminated 4/4 stock face-to-face to build the legs, each leg would show ordinary-looking edge grain on

two opposite faces and ray fleck on the other faces. Instead, we used a simple technique to place extraordinary figure on both adjacent outside surfaces as shown in the leg above. Here's how to make this splined-miter joint with a filler.

FIRST CUT THE VISIBLE LEG PIECES AND SPLINE

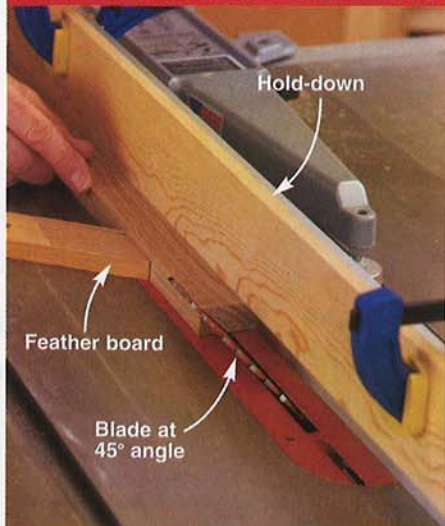

STEP 1: Tilt a combination blade away from the table saw fence at 45°. (On this right-tilt saw, we moved the fence left of the blade.) Set the fence to cut the upper (outside) face of your 4/4 workpiece 1/16" wider than the leg's final width. Clamp a board to the fence to serve as a hold-down, install a feather board, and bevel-rip to form a leg corner.

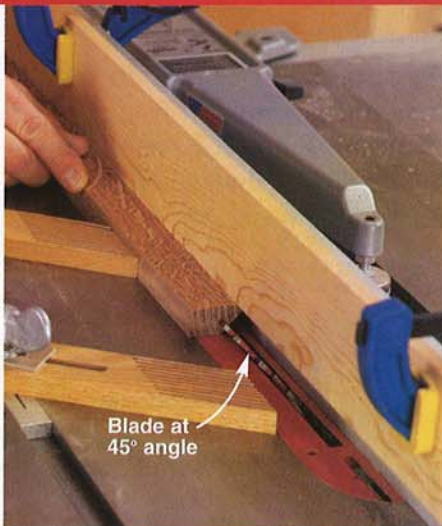

STEP 2: Remove the feather board and set the fence to cut spline slots in the bevel-ripped edges where shown, centered 1/4" from the inside corner. Adjust the blade height to cut a kerf 1/4" deep. Replace the feather board and add a second feather board where shown for extra support. Now, using a pushstick, cut a slot on each piece.

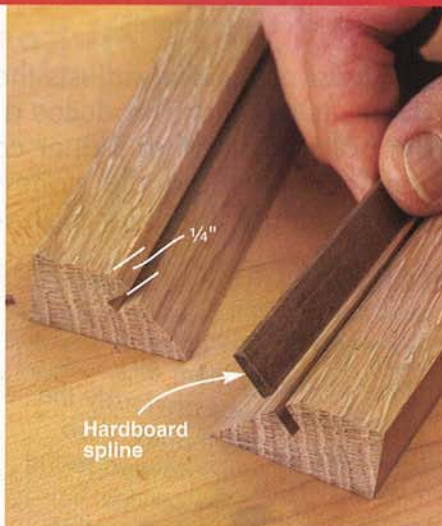

STEP 3: On your table saw, cut a piece of 1/8" hardboard to make a spline 7/16" wide and the same length as the leg corners. This spline aligns the miter joint during assembly. By keeping the spline slightly narrower than the combined depth of the two kerfs, you ensure that it won't bottom out and cause assembly problems.

Continued on page 34

Make an Impression

Make an impression on your friends, family, and co-workers with a beautiful handcrafted pen project from Penn State Industries.

Whether you are an experienced woodturner or just getting started, making an extraordinary pen project is fast, easy and extremely rewarding. Choose from our huge selection of projects that include pens, pencils, keychains, kaleidoscopes, pen lights, yo-yos, bottle stoppers, perfume kits, candle sticks, and much more!

Penn State Industries carries everything you need to participate in this favorite pastime; a vast selection of lathes, exotic woods, dedicated pen making tools, abrasives, and finishes.

Visit our web-site to share ideas on our forum, download instructions from our library, and order our products.

Call the number below for our free catalog.

www.pennstateind.com

or call us at

1-800-377-7297

Penn State Industries

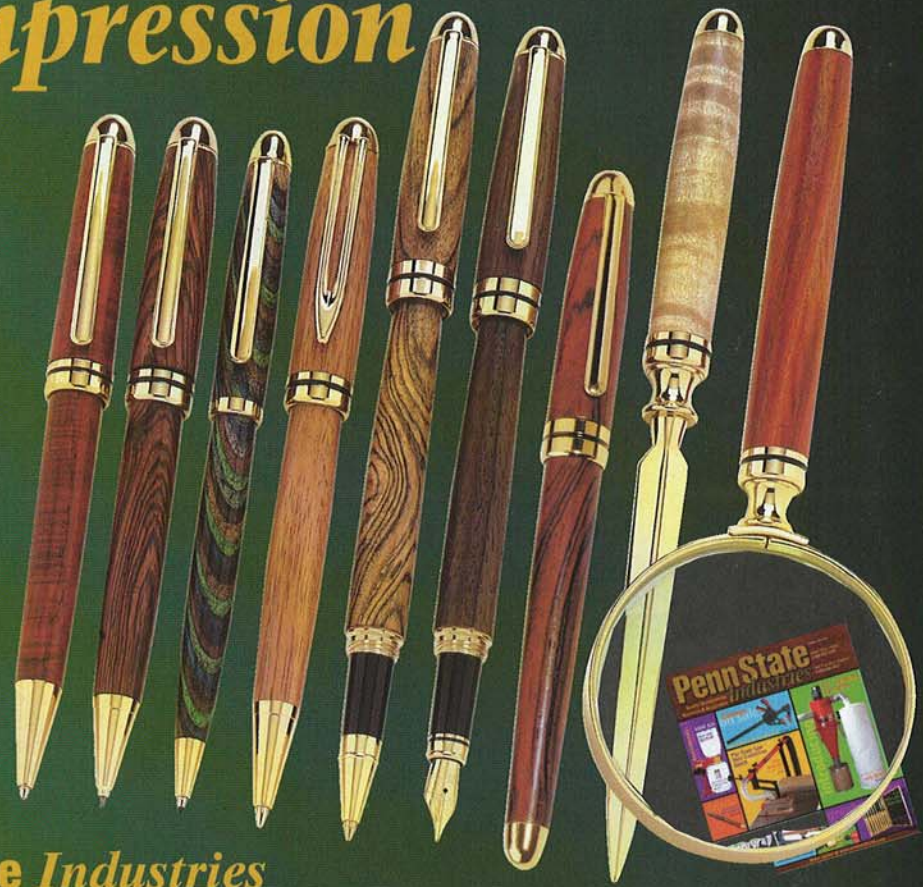

E-Z Action Aluminum Bar Clamps

- Strong and straight!
- Flat bottom for easy work positioning
- Fast action large quick-release jaws

A Standard - 1-1/2" x 1-5/8" jaws

	LENGTH	VALUE	PRICE
#CDWM04	24"	\$25	\$11.45
#CDWM05	36"	\$27	\$13.55
#CDWM06	48"	\$30	\$16.70

*Please order in multiples of 2 clamps



B Deep Jaw - 1-1/2" x 3-3/4" jaws

	LENGTH	VALUE	PRICE
#CDWM07	24"	\$30	\$13.45
#CDWM08	36"	\$33	\$15.55
#CDWM09	48"	\$35	\$18.70

C Hardwood Hand Screw Clamps

The jaws on these clamps won't damage your work and holds tight over large areas.

- Clamp parallel or non-parallel surfaces
- Hardwood jaws

	LENG.	OPEN	VALUE	PRICE
#CDWM10	8"	4-1/2"	\$15	\$5.75
#CDWM11	10"	5-1/2"	\$18	\$6.75
#CDWM12	12"	8"	\$20	\$8.35
#CDWM13	14"	9"	\$27	\$9.75

Free shipping on clamp orders over \$100

CLAMPS ON SALE!!!



Save!



D PSI Clamp-n-Spread

- Powerful, fast and easy use
- Comfort cushion pistol grip
- Heavy duty steel bar
- Convenient clamp release button
- Converts from clamp to spreader

	LENGTH	VALUE	PRICE
#CDWM01	12"	\$20	\$9.95
#CDWM02	24"	\$23	\$12.95
#CDWM03	36"	\$27	\$14.95

E PSI Power/Spreader

- Fast action one hand operation
- Quick release trigger
- 2-7/8" throat depth
- Clamp can convert into a spreader

	LENGTH	VALUE	PRICE
#CDWM14	12"	\$20	\$9.95
#CDWM15	24"	\$23	\$12.95
#CDWM16	36"	\$27	\$14.95

F Fast-Action Ratcheting Bar Clamp

- 2-3/4" throat
- Quick set and release
- Spring-loaded clutch plates
- Hardwood handle

	LENGTH	VALUE	PRICE
#CDWM17	6"	\$7	\$3.95
#CDWM18	12"	\$8	\$4.65
#CDWM19	24"	\$10	\$5.70
#CDWM20	36"	\$12	\$6.75

Deep Throat Sliding Bar Clamps

Clamps quickly and firmly into the center of boards.

- Heavy cast iron clamping heads
- 1/2" Acme-type screw threads
- Fast acting with large easy to grip wooden handles

G 5" Deep Jaw

	LENGTH	VALUE	PRICE
#CDWM21	6"	\$9	\$4.70
#CDWM22	12"	\$13	\$5.75
#CDWM23	24"	\$17	\$7.75
#CDWM24	36"	\$20	\$9.95

H 7" Deep Jaw

	LENGTH	VALUE	PRICE
#CDWM25	12"	\$20	\$9.95
#CDWM26	24"	\$25	\$11.95
#CDWM27	36"	\$30	\$12.95

For a FREE catalog - visit us on the web at: www.pennstateind.com

Circle No. 2156

★ QUALITY ★ ECONOMY ★ VALUE ★

To order, visit theclampstore.com or call us toll-free 1-800-377-7297

Penn State Industries

GARAGE

Sweet

GARAGE

Turn yours into a dream garage with a \$10,000 MAKEOVER

It's America's Ultimate Garage Contest. Win a \$10,000 garage makeover courtesy of Rust-Oleum® EPOXYShield®. Describe what your garage means to you, what makes for an ideal garage, and why you deserve a garage makeover, in 300 words or less. Then, include a color photo of the interior of your garage. The winner will receive "An Ultimate Garage Makeover" from a Home Depot® approved contractor. Included in your new look will be a showroom-quality floor protected with EPOXYShield Garage Floor Coating.

ONE GRAND PRIZE
\$10,000 Garage Makeover

ONE SECOND PRIZE
\$5,000 Garage Makeover

25 SEMI FINALIST PRIZE PACKAGES
EPOXYShield Garage Floor Coating Kits



RUST-OLEUM®

stopping rust is just the start.™

No purchase necessary. Contest is open May 15 - August 2, 2004, to legal U.S. and Canada residents ages 18 and over. Enter online at: epoxyshield.com, rustoleum.com, homedepot.com, or mail entries, including first and last name, date of birth, address (including zip code), telephone number, color photograph of the interior of your garage and a description, in 300 words or less, of your ideal/ultimate garage and why you are most deserving of your dream garage.

Mail entry in a stamped envelope to: America's Ultimate Garage Contest, P.O. Box 39101, Chicago, IL 60639. Entries must be postmarked by Monday, August 2, 2004. Void where prohibited. For official contest rules visit your participating Home Depot, epoxyshield.com or homedepot.com.



You can do it.
We can help.

workshop **savvy**

NOW ASSEMBLE THE LEG

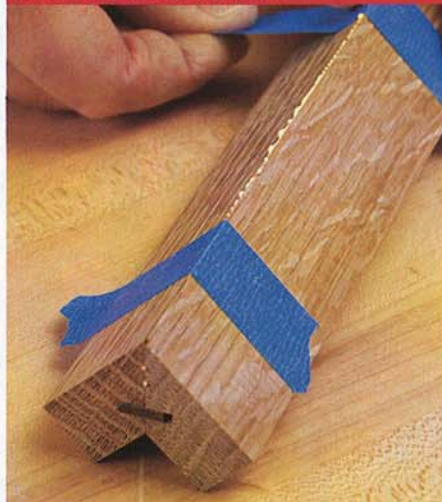

STEP 1: Apply glue to both mitered surfaces and the spline. Slip the spline into place, join the two leg corners, and apply masking tape to hold them until the glue dries. Tape across the joint at 6" intervals. Clamp any area that refuses to line up.

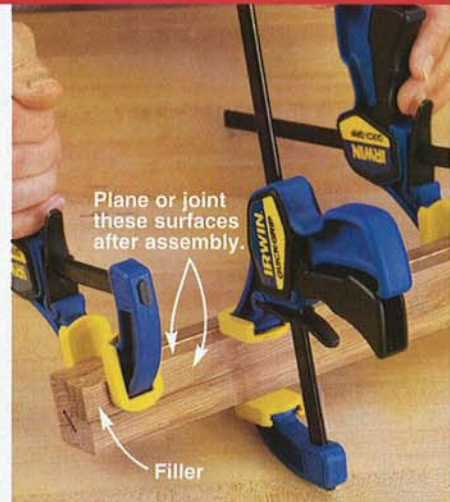

STEP 2: Rip a filler piece (3/4"x3/4" for the clock leg) to fit the L-shape space of the leg assembly and crosscut it to the same length as the leg. Glue and clamp it in place. After the glue dries, reduce the leg to its final dimensions with a jointer or planer.

Dress up a narrow edge to match your design

The front of the mission clock shows the edge of three divider-frame rails: one at the top of the case, one at the bottom, and one between the doors. A simple step transforms each ordinary edge into an attractive detail complementing the doors and legs.

Select a nicely figured scrap piece as long as the exposed edge and rip a blank as wide as the edge thickness. Now place the blank with its figured face against your table saw rip fence and cut a 1/4"-thick strip. Glue this strip on the edge to make the difference shown. Keep this technique in mind when you build shelves too.

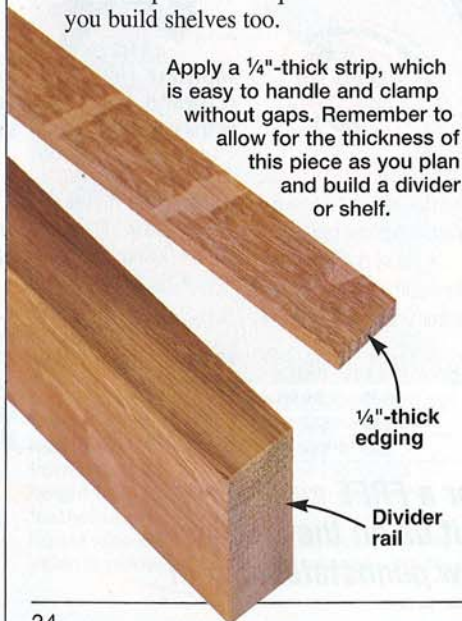

Apply a 1/4"-thick strip, which is easy to handle and clamp without gaps. Remember to allow for the thickness of this piece as you plan and build a divider or shelf.

Cut wide bevels according to the end grain

Finally, here's a specialized technique that applies to wide, shallow bevels like the one on the top trim of the mission clock. As you see, we looked at end grain and chose a workpiece with grain sloping toward one corner. Cut a bevel across the grain, as shown, for the best chance of exposing ray fleck (in oak, ray fleck is most prevalent on surfaces with growth rings that run perpendicular to those surfaces).

End grain tells you where to cut a wide bevel on a white oak or red oak board. Orient the beveled edge so that it's perpendicular to the grain direction.

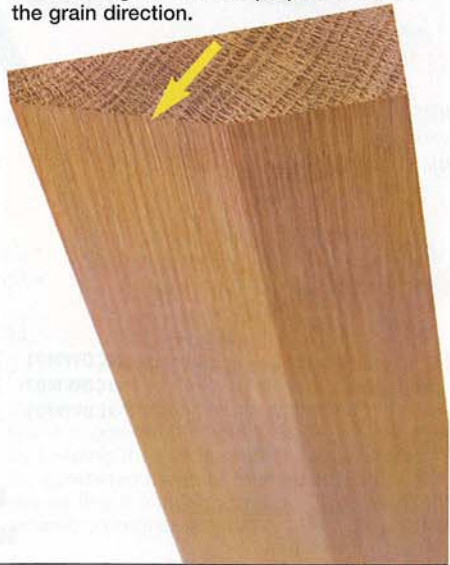

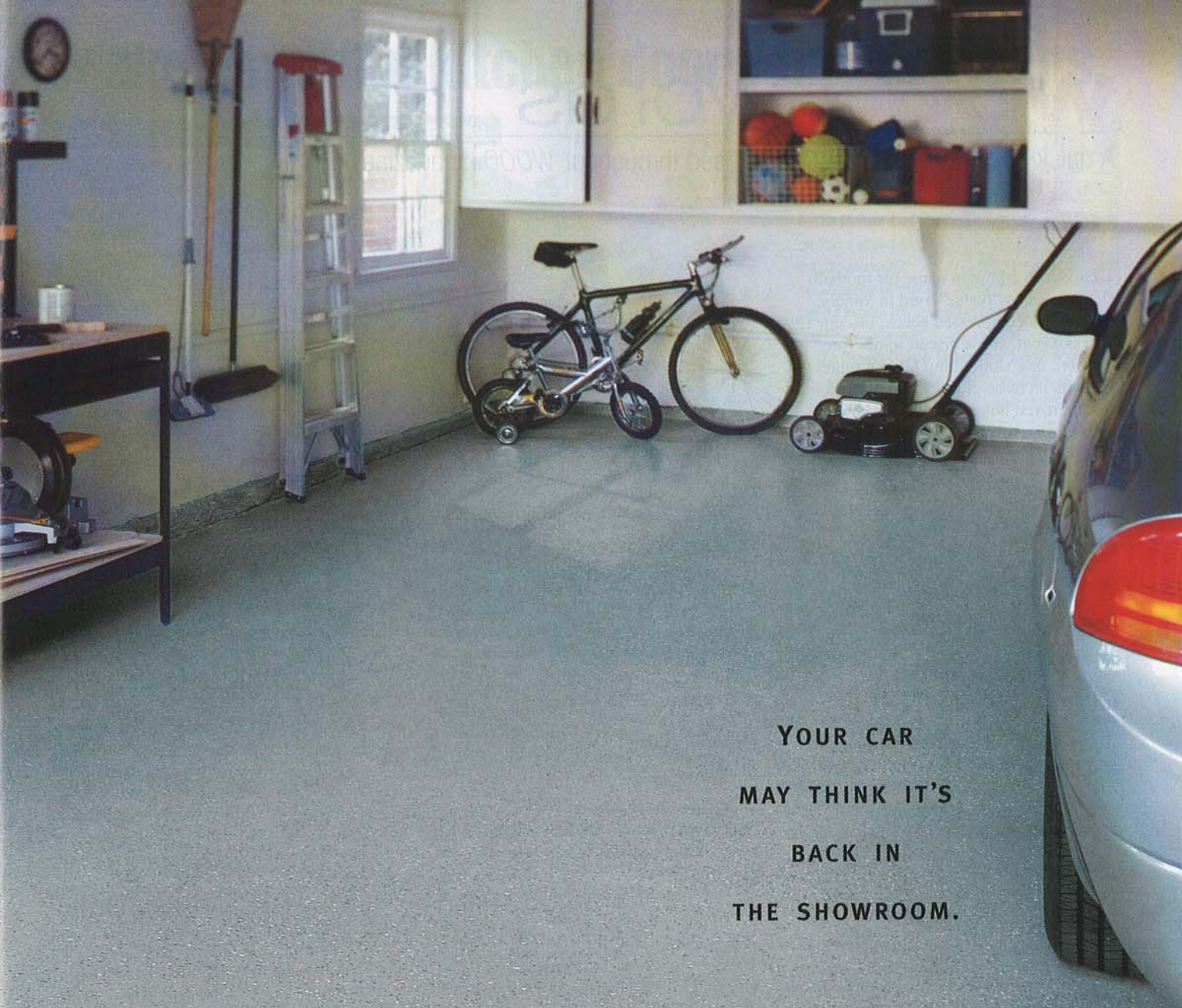

YOUR CAR
MAY THINK IT'S
BACK IN
THE SHOWROOM.

Enjoy the satisfaction that comes from something as surprisingly simple as creating your own showroom quality garage floor. Just one coat of easy-to-apply Rust-Oleum® EPOXYShield® gives you a professional finish that



withstands gasoline, antifreeze, motor oil, salt, even hot tire pick up. Easy to apply. Easy to keep clean. And easy on the eyes. With Rust-Oleum EPOXYShield, friends won't ask what's under your car's hood, just what's under your car.

RUST-OLEUM®
stopping rust is just the start.™

rustoleum.com

Available at THE HOME DEPOT®



You can do it.
We can help.

wood words

A quick guide to must-know terms used throughout *WOOD*® magazine

Biscuit: A common name for football-shape wooden “plates” used in joinery. Made from compressed beech, biscuits fit into slots cut with a biscuit joiner (see *bottom*), or a slot-cutting bit in a router. Biscuits increase glue surface in the joint for improved holding power and hold the joint in alignment during clamping. Three traditional sizes (#0, #10, #20) are most common, but several other sizes exist.



Biscuits shown full-size #0



#10



#20

Biscuit joiner: A specialized power tool made to cut slots that accept hardwood biscuits. The tool most often resembles an angle grinder with a precision fence and base added on. These parts of the tool work together to align a retractable circular blade that plunges into the mating joint members at the desired slot location. Each plunge creates one half of the biscuit slot.

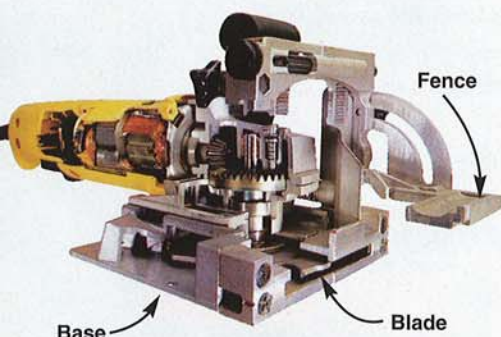

Materials list: A chart accompanying a woodworking project that details every part by letter, name, dimensions, material, and quantity. The list may include notes that indicate special cutting instructions.

Cutting Diagram: An illustrated guide that depicts the quantities and sizes of boards required for a project as well as where each part should be laid out to minimize waste. While extremely handy for defining lumber needs, cutting diagrams can't account for grain variations in solid wood stock or sheet goods, or for defects in solid stock. So, use a cutting diagram as a guideline only.

Cutting Diagram

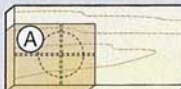

3/4 x 5 1/2 x 12" Bird's-eye maple (.5 bd. ft.)

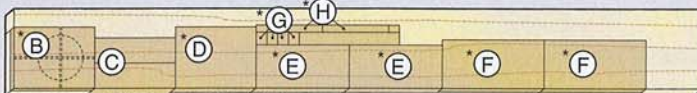

3/4 x 5 1/2 x 48" Cherry (2 bd. ft.)

Materials List

Part	FINISHED SIZE			Matl.	Qty.
	T	W	L		
A face	3/4"	4 1/4"	5 5/8"	BEM	1
B backer	1/4"	4 1/4"	5 5/8"	C	1
C sides	3/4"	1 3/4"	5 5/8"	C	2
D back	1/2"	4 1/4"	5 5/8"	C	1
E sub top and bottom	1/2"	3"	6 1/2"	C	2
F top and bottom	3/8"	3 3/8"	7 1/8"	C	2
G* capitals	1/2"	7/8"	3/4"	C	4
H* pillars	1/2"	3/4"	4 5/8"	C	2

*Parts initially cut oversize. See the instructions.

Materials key: BEM—bird's-eye maple, C—cherry.

How to stack lumber for air drying

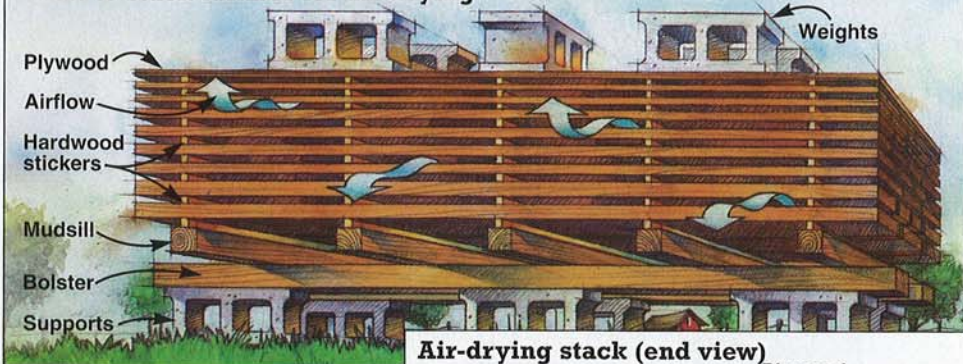

Air-dried lumber: Boards that have dried naturally by stacking them in the open air, as shown *above* and *right*. Air flows between the boards, allowing the moisture in the wood to evaporate. Air drying can take as long as one year per inch of board thickness. In all but the driest regions, moisture content rarely falls below 12 to 20 percent without additional drying indoors.

Kiln-dried lumber: Stickered boards dried at an accelerated rate by exposure to warm, dry air inside a chamber called a kiln. By controlling airflow, humidity, and temperature, this process reduces moisture content in just days or weeks to desired levels—6 to 10 percent for hardwoods and high-grade softwoods, 12 to 20 percent for construction lumber. ♣

Air-drying stack (end view)

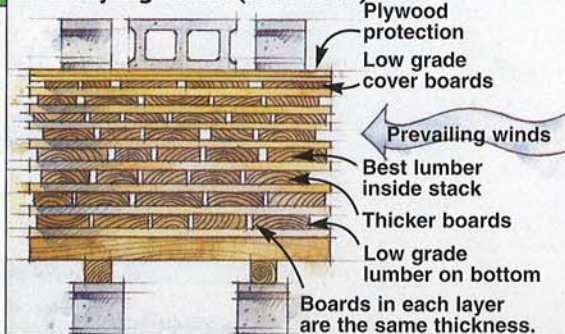

Make beautiful kitchen doors and drawers.

MLCS Pro Cabinetmaker 6 Piece Router Bit Set

This professional quality 1/2" shank set contains six carbide tipped bits needed for fine cabinet making, raised panel doors, kitchen table top and drawer assembly. Designed for up to 3/4" wood thickness.

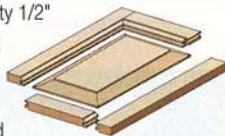

1. The **Ogee Raised Panel** bit (in the Standard Set) puts a classic ogee edge on the free floating central panel in your door. 2-3/4" large diameter.

2. The **Ogee Raised Panel with Undercutter** (in the Undercutter Set ONLY) produces a flush or reduced upper panel profile. 3-1/8" large diameter.

3. Our **Matched Rail and Stile** set creates precisely mated rails and stiles that form an extremely durable, classic frame for your door. 1-5/8" large diameter.

4. Use the **Glue Joint** bit when the central panel needs to be wider than



your stock. Rout two or more pieces of stock (1-1/4" max.) with reverse cut edge joints to reach the required width.

1-3/4" large diameter.

5. The **Drawer Lock** bit creates a strong joint that fits precisely because one bit makes the cut in both the drawer front and the drawer side. 1-3/4" large diameter.

6. The **Round Over & Ogee Door Lip** bit finishes your door edge professionally in one pass.

All bits are intended for use in a router table only.

#1453 6 Piece Undercutter Set\$135.95

#1452 6 Piece Standard Set\$114.95

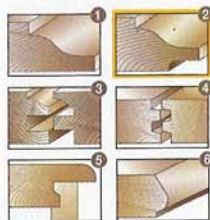

Raised Panel Instructional Video

Watch a woodworking professional make a raised panel, rail and stile frame, and other types of cabinet doors. 40 minutes of instruction.

#1438 List \$19.95.....\$9.95



Router Table Top and Fence Special

The Table Top

24" x 32", heavy 1-3/8" tabletop has a sturdy MDF core, durable melamine surface and polyethylene edges. A 12" x 9" router insert with guide pin is pre-mounted. Hex head adjusting screws level insert to top while small magnets hold the insert in place. Removable rings allow 3 openings (1-3/16", 2-5/8", and 4") that fits most bits. Includes pre-installed aluminum Miter slot and two T-Track slots for fence.



STAND NOT INCLUDED

The Router Fence

36" long anodized aluminum angle keeps the fence at 90° (within .010") for accuracy. The 6" split fence is constructed with an MDF core and melamine surface. The

T-slot allows attachment of featherboards or jigs to the fence. The split fence includes a dust collection port. T-slot mounted fence adjusts independently and varies openings around the router bit. Plastic safety guard helps protect eyes. Measuring tape on fence reads both right to left and left to right.

Optional Router Stand*

Available individually, this sturdy frame is 27" x 19" x 33" and weighs 13 lbs.

#1462 Reg. \$70.....\$45.95

#1461 Table Top & Fence....\$189.95

Raised Panel Door Sets

Making raised panel doors only? These carbide tipped sets include a cove raised panel router bit with ball bearing and an ogee reversible combo rail and stile bit.



#1463 1/4" shank 2" LD Set\$59.95

#1464 1/2" shank 3-1/2" LD Set ..\$69.95

Router Collet Extension

Give your 1/2" shank router bits an additional 2-1/4" when you extend your router bit through the router table top with our router collet extension. The router collet extension makes it possible to use all diameter of bits safely. Instructions included.



#1456\$24.95



66 Piece Router Bit Set

NEW! Improved Storage Box can be wall mounted.

Includes these carbide tipped bits:

8 Straight, 5 Dovetail, 6 Round Over, 6 Cove, 4 Chamfer, 3 Round Nose, 3 Hinge Mortising, Bevel, Bevel Trim, Cove Sign Lettering, Panel Pilot, 2 Roman Ogee, Multi Bead/Reed Bit, 2 Slot Cutter, Flat Bottom Sign Lettering, Flat Bottom Round Over, Double Fillet & Cove, Double Cove & Bead, Double Round Over, Rabbeting, Keyhole, Dish Cutter, Ogee Filet, Groove Forming Classical, Point Cutting Round Over, 2 Flush Trim, 3 Core Box, Classical Bit, 3 V-Groove, 2 Edge Beading, 3 bearings and an allen wrench.



#1459 1/4" shank set\$189.95

#1460 1/2" shank set\$189.95



ROUTER BITS AND PROFESSIONAL WOODWORKING PRODUCTS

TO ORDER CALL: 1-800-533-9298

WEB: MLCSWOODWORKING.COM

MLCS LTD., P.O. BOX 4053DE, RYDAL PA, 19046

©2003

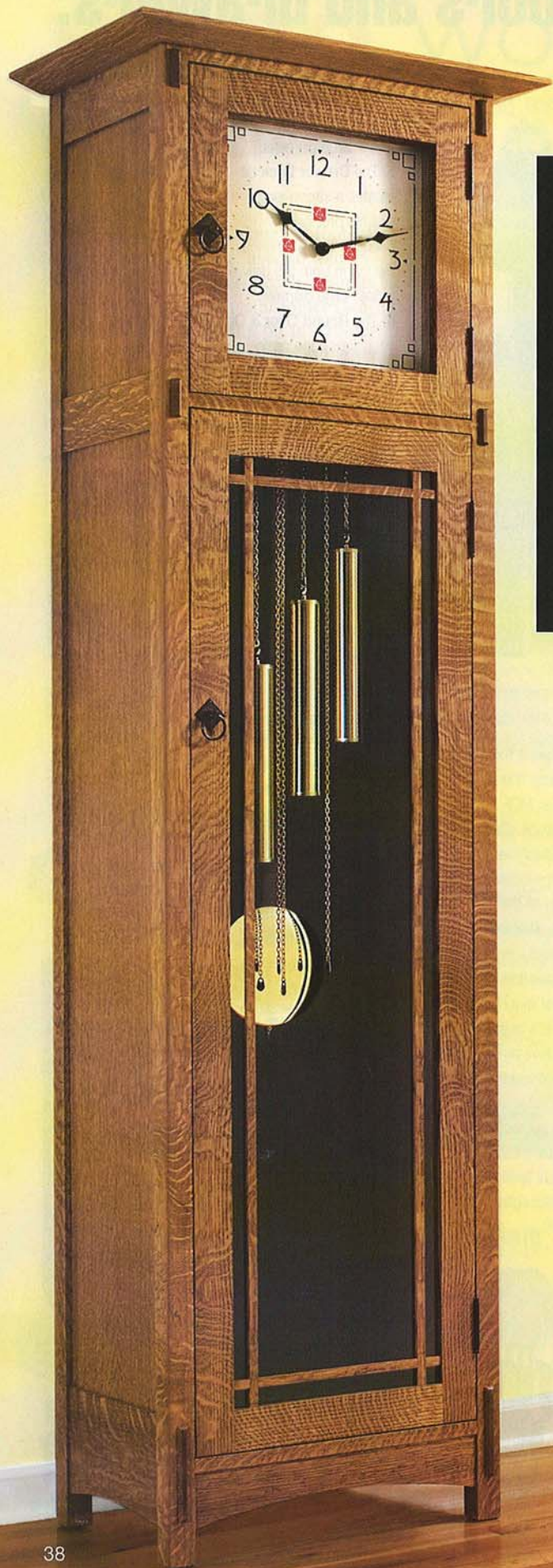

■ ARTS AND CRAFTS ■

HEIRLOOM TALL CLOCK

Classic clean lines and eye-catching quartersawn oak combine to make this a project that will stay with your family for generations.



Striking looks aside, this masterpiece tall clock has several features that reflect simplicity and flexibility in design. For starters, the case uses straightforward stub-tenon-and-groove and mortise-and-tenon joinery. Added to this, easy-to-make leg-mortise plugs give the side rails a time-honored through-tenon look. Also, you have a choice of a mechanical clock movement, as shown *at left*, or a less-expensive battery-powered quartz chiming movement with separate pendulum drive. No matter the movement you select, the case construction remains the same. Finally, if you wish to build the clock using quartersawn white oak, as we did, you'll find the design allows for maximum display of this wood's treasured ray fleck figure.

Kevin Boyle
Senior Design Editor

2 SIDE-RAIL TENON DETAILS (Inside face shown)

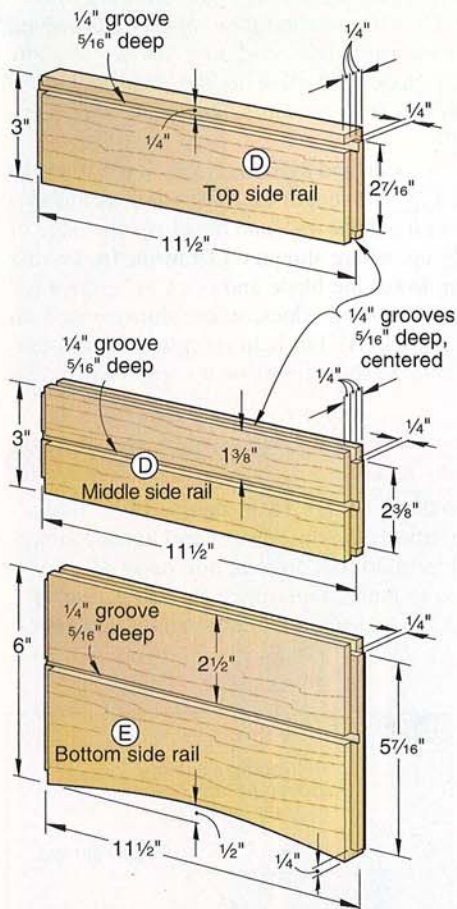

2 Cut the $\frac{1}{8}$ "-thick tempered-hardboard splines (B) $\frac{7}{16}$ " wide and 81" long. Then, glue and assemble the corners (A) and splines, keeping their ends flush. Apply pieces of easy-release painter's tape every 6" across the assemblies to hold the beveled joint tight. When the glue dries, remove the tape, and scrape off any squeeze-out from the inside and outside surfaces.

3 Cut the $\frac{3}{4}$ "-thick fillers (C) $\frac{3}{4}$ " wide and 81" long. Then, glue and clamp them to the corner assemblies, where shown, keeping their ends flush. When the glue dries, scrape off any squeeze-out. Next, using your thickness planer or a horizontal drum sander, plane or sand the corners (A) flush with the fillers, leaving $1\frac{1}{2}$ "-square legs. Now, cut the legs to the finished length by trimming their ends.

4 Rout $\frac{1}{8}$ " chamfers along the legs' bottom edges. To keep the leg locations straight, mark their top ends ("front right," for example). Also, to ensure you machine the legs' mortises, grooves, and rabbets in the correct faces, mark the legs' inside faces, where shown on **Drawing 1b**, keeping in mind the left and right pairs of legs are mirror images.

3 CASE ASSEMBLY

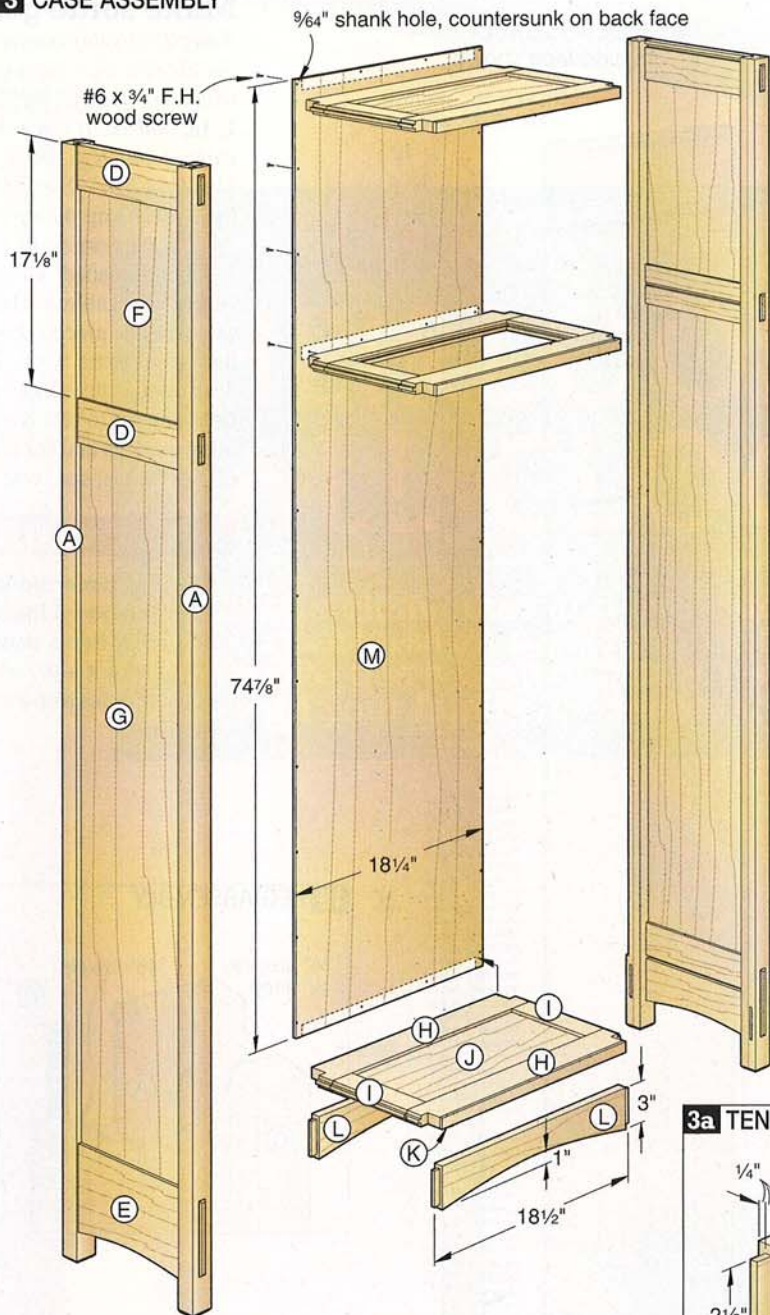

5 Lay out the $\frac{1}{4}\times 2\frac{1}{2}$ " mortise at the bottom of each leg, where dimensioned on **Drawing 1**, to receive the bottom rail (L) tenons, where shown on **Drawing 3**. Note that the mortises are *offset* (not centered) on the legs. Then, on the *front* face of the *front* legs, lay out the $\frac{1}{4}\times 1\frac{3}{4}$ " upper mortises and the $\frac{1}{4}\times 4\frac{3}{4}$ " lower mortises, where dimensioned, for the leg-mortise plugs (N, O). These mortises are *centered*.

6 Using a $\frac{1}{4}$ " brad-point bit in your drill press and a fence to keep the holes aligned, drill the mortises to the depths shown. Then, square their sides and ends with a chisel. For help on cutting mortises and tenons, see *page 68*.

7 Using a $\frac{1}{4}$ " dado blade, cut an offset $\frac{5}{16}$ "-deep groove stopped $2\frac{1}{4}$ " from the bottom on the marked inside face of each leg, where dimensioned on **Drawing 1**. (You'll need to change the fence position for two of the legs.) Now, along the back inside edge of the *rear* legs, cut a $\frac{1}{4}$ " rabbet $\frac{3}{8}$ " deep, stopped 5" from the bottom, where shown on **Drawings 1** and **1b**, for the back (M). For an easy way to form the stopped grooves and rabbets, see the **Shop Tip**, *opposite page, right*.

3a. TENON DETAIL

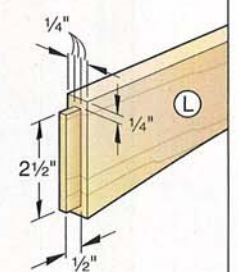

CUT THE SIDE-RAIL TENONS

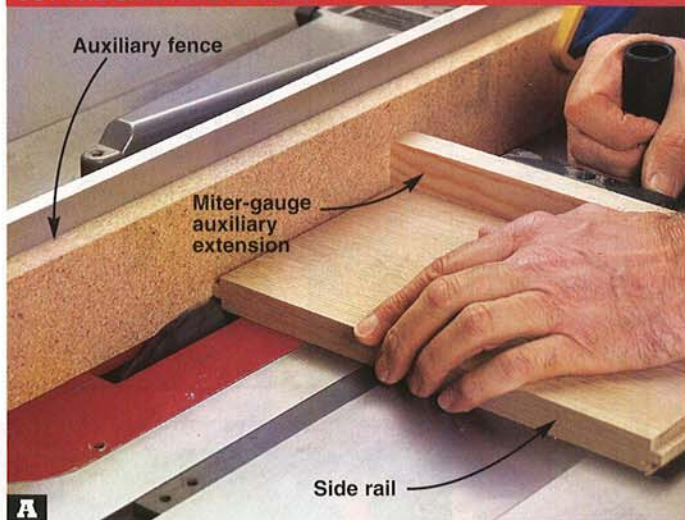

Using an auxiliary fence positioned $\frac{1}{4}$ " from the outside of the dado blade and a miter-gauge auxiliary extension for backup, cut the tenons on the side rail's ends.

POSITION THE MIDDLE SIDE RAIL

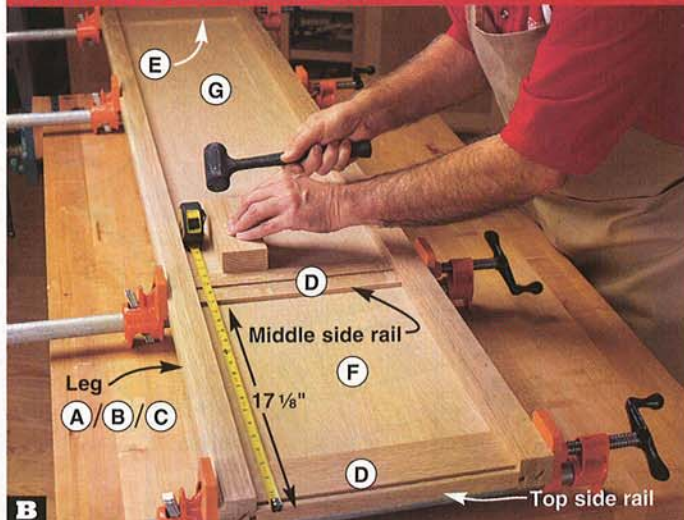

Using a mallet and a scrap wood block, tap the middle side rail (D) to position its top edge $17\frac{1}{8}$ " from the assembly's top. Mark the rail's location for easy realignment.

Note: Because both sides of the side panels (F, G) that go in the $\frac{1}{4}$ " leg grooves are visible in the clock and our quartersawn white oak plywood had only one good side, we veneered these parts to provide two good sides, as explained later. The overall plywood/veneer thickness measured exactly $\frac{1}{4}$ ".

Complete the sides

1 Cut the top/middle side rails (D), bottom side rails (E), and top and bottom plywood side panels (F, G) to the sizes listed in the **Materials List**. If you wish to veneer the less attractive side of the quartersawn white oak plywood, as we did, see **Sources**. Apply the veneer as directed in the supplied instructions.

2 Using a $\frac{1}{4}$ " dado blade, cut a $\frac{5}{16}$ "-deep groove centered along both edges of the middle side rails (D) and along one edge of the top side rails (D) and bottom side rails (E), where shown on **Drawing 2**.

3 Adjust your dado blade, if needed, and cut $\frac{1}{4}$ " grooves $\frac{5}{16}$ " deep on the *inside* face of the side rails (D, E), where dimensioned, to receive the tongues on the divider frames (H/I/J/K). See **Drawing 3**.

4 To form tenons on the ends of the side rails, set up your tablesaw as shown in **Photo A**. Next, cut a $\frac{1}{4}$ "-long tenon in scrap, and test-fit it in the legs' grooves. Adjust your setup if needed. When satisfied, cut the tenons on the rails' ends. Then, place the top side rails (D) on edge and trim the tenons' width to $2\frac{7}{16}$ ". Repeat for the bottom side rails (E), where shown, to trim their tenons to $5\frac{7}{16}$ " wide.

5 Using a fairing stick, draw the arch on the bottom side rails, where dimensioned on **Drawing 2**. Bandsaw and sand the arches to shape.

6 Sand the legs (A/B/C), side rails (D, E), and side panels (F, G) with 220-grit sandpaper. Dry-assemble and clamp the parts together to form the two sides, *exactly* positioning the middle side rails (D), as shown in **Photo B**, to ensure that the clock movement and the clock face align later. Then, disassemble and glue and clamp the parts together.

Add the divider frames

1 Cut the divider stiles (H), divider rails (I), and plywood divider panels (J) to size to make a top, middle, and bottom divider frame, where shown on **Drawings 3** and **4**. Note that only the top and bottom frames have panels. Then, cut the $\frac{1}{4}$ " edging (K) to $\frac{3}{4}$ " wide and $19\frac{1}{4}$ " long. Cut it so quartersawn figure shows on its face.

2 Glue and clamp the edging to three stiles (H) for the front. When the glue dries, sand the edging flush.

3 Using a $\frac{1}{4}$ " dado blade, cut $\frac{5}{16}$ "-deep grooves centered on one edge of all of

the stiles (H) and rails (I), where shown on **Drawing 4**. Then, adjust the blade height and cut $\frac{1}{4}$ " tenons on the rails' ends.

4 Glue and clamp together the divider frames and panels. When the glue dries, sand them smooth. Then, lay out notches in the stiles (H) to fit around the legs, where dimensioned. Bandsaw the notches.

5 Cut $\frac{1}{4}$ " tongues along the notched ends of the frames, where shown, to fit the grooves in the side rails (D, E).

6 Cut the bottom rails (L) to size. Then, cut $\frac{1}{4}$ " tenons $\frac{1}{2}$ " long on the rails' ends, where shown on **Drawings 3** and **3a**, to fit the legs' mortises. Make certain the shoulder-to-shoulder length of the rails exactly matches the $17\frac{1}{2}$ " notch-to-notch length of the divider frames' front stiles (H), where shown on **Drawing 4**, to ensure that the clock case assembles correctly. Draw, bandsaw, and sand the rails' arches to shape.

7 Glue and assemble the sides (A through G), divider frames (H/I/J/K), and bot-

SHOP TIP

Don't get stumped when cutting stopped grooves or rabbets

Here's an easy way to form stopped grooves or rabbets, such as the ones for the clock's legs (A/B/C). Draw a line on the saw table where a blade tip at the front of the blade passes through the insert, where shown on the drawing, *right*. Then, draw a line on the part where you want to stop the groove or rabbet (for example, $2\frac{1}{4}$ " from a leg's bottom for the stopped $\frac{1}{4}$ " groove). Now, cut the groove, stopping when the two marked lines align. The blade will leave a radiused area at the stopped end. Square it with a chisel.

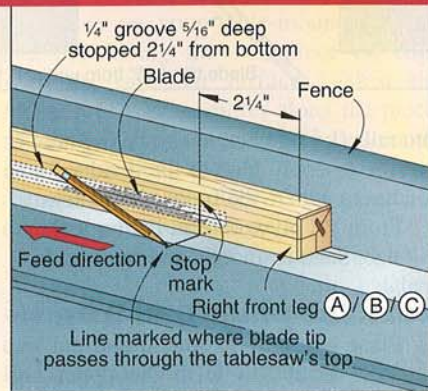

4 DIVIDER FRAMES (3 needed)

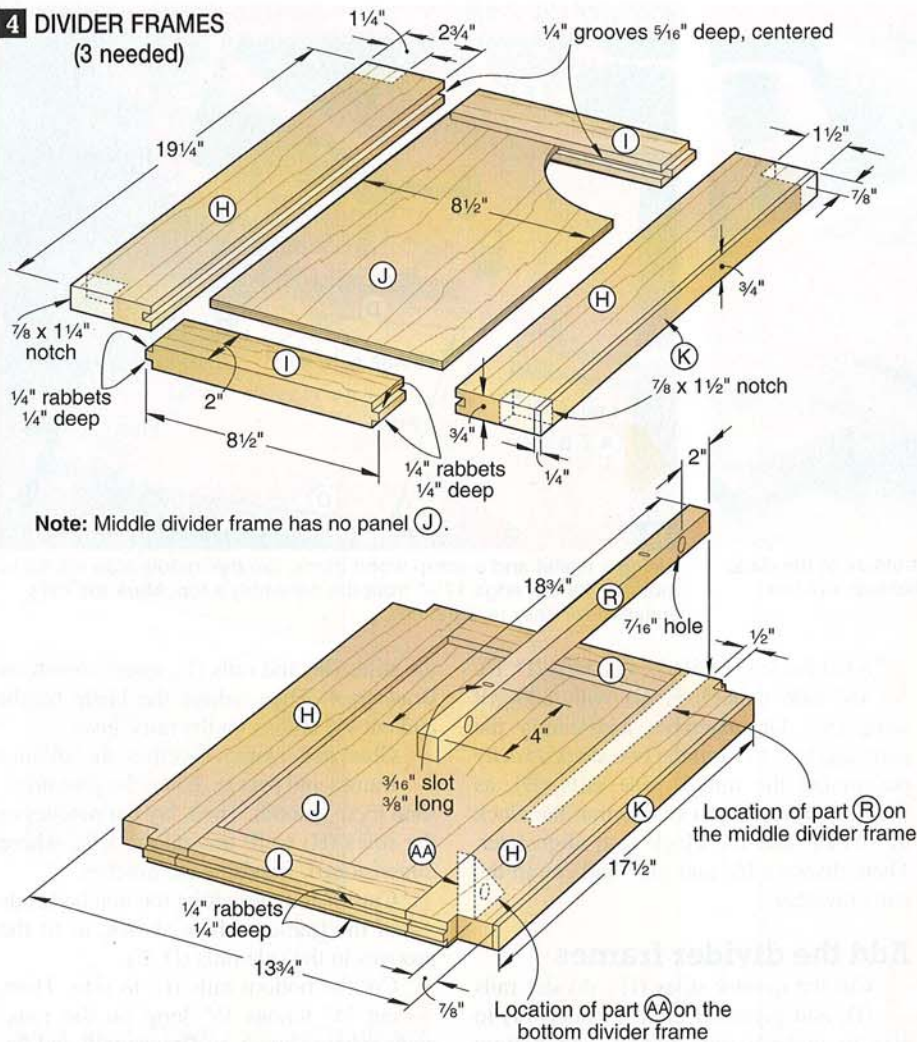

Note: Middle divider frame has no panel (J).

5 LEG-MORTISE PLUG DETAIL

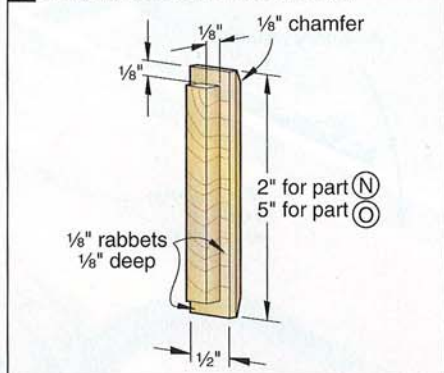

ASSEMBLE THE CASE

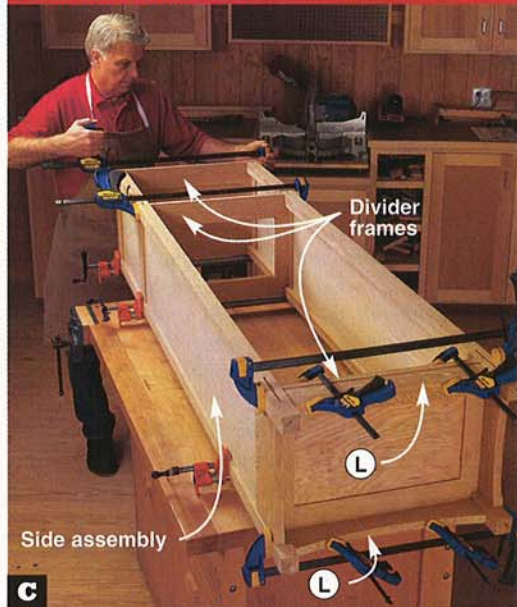

Glue and clamp the divider frames (H/I/J/K) and bottom rails (L) between the side assemblies, making sure to locate the frame without a panel in the middle.

6 CUTTING THE LEG-MORTISE PLUGS

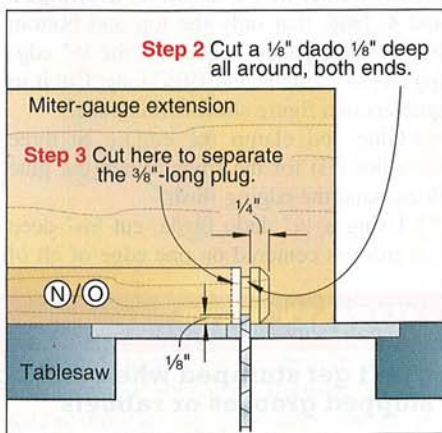
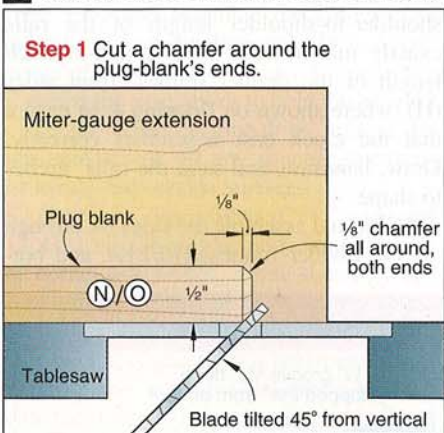

tom rails (L) together, as shown in **Photo C**. Be sure to apply glue to the divider-frame notches to adhere the frames to the legs.

8 From 1/4" plywood, cut the back (M) to size. Sand it smooth, and set it aside.

Next: the plugs and trim

1 Plane stock to 1/2" thick, and cut two 2x8" blanks to form the upper leg-mortise plugs (N) and a 5x8" blank to

form the lower leg-mortise plugs (O), where shown on **Drawings 1** and **5**. Note that the plugs will show face grain on their sides to give the appearance that the side rails (D, E) have through tenons.

2 Using your tablesaw, follow the setup and instructions on **Drawing 6**, steps 1 through 3, to form the plugs from the blanks. Sand the plugs smooth. Then, glue them in the legs' mortises.

3 Plane stock to 1" thick, and cut a 4 3/8x64" workpiece to form the side and front trim (P, Q) for the top. Angle your tablesaw blade to 18° from vertical, and bevel-rip the workpiece, where dimensioned on **Drawing 7a**. Then, rout a 1/8" chamfer along an edge of the workpiece, where shown. Now, miter-cut the trim to the listed lengths, cutting the pieces in sequence (side, front, side) to maintain a continuous grain flow.

4 Adjust your biscuit-joiner fence to center the cutter on the trim's thickness. Plunge slots for #20 biscuits in the mitered ends, where shown on **Drawing 7**. Next, drill countersunk shank holes through the top of the trim 3/8" from its back edge, where shown on **Drawings 7** and **7a**. Then, glue and assemble the trim with biscuits. When the glue dries, position the trim on the case, flush with the rear legs' back face and centered side-to-side. Clamp it in

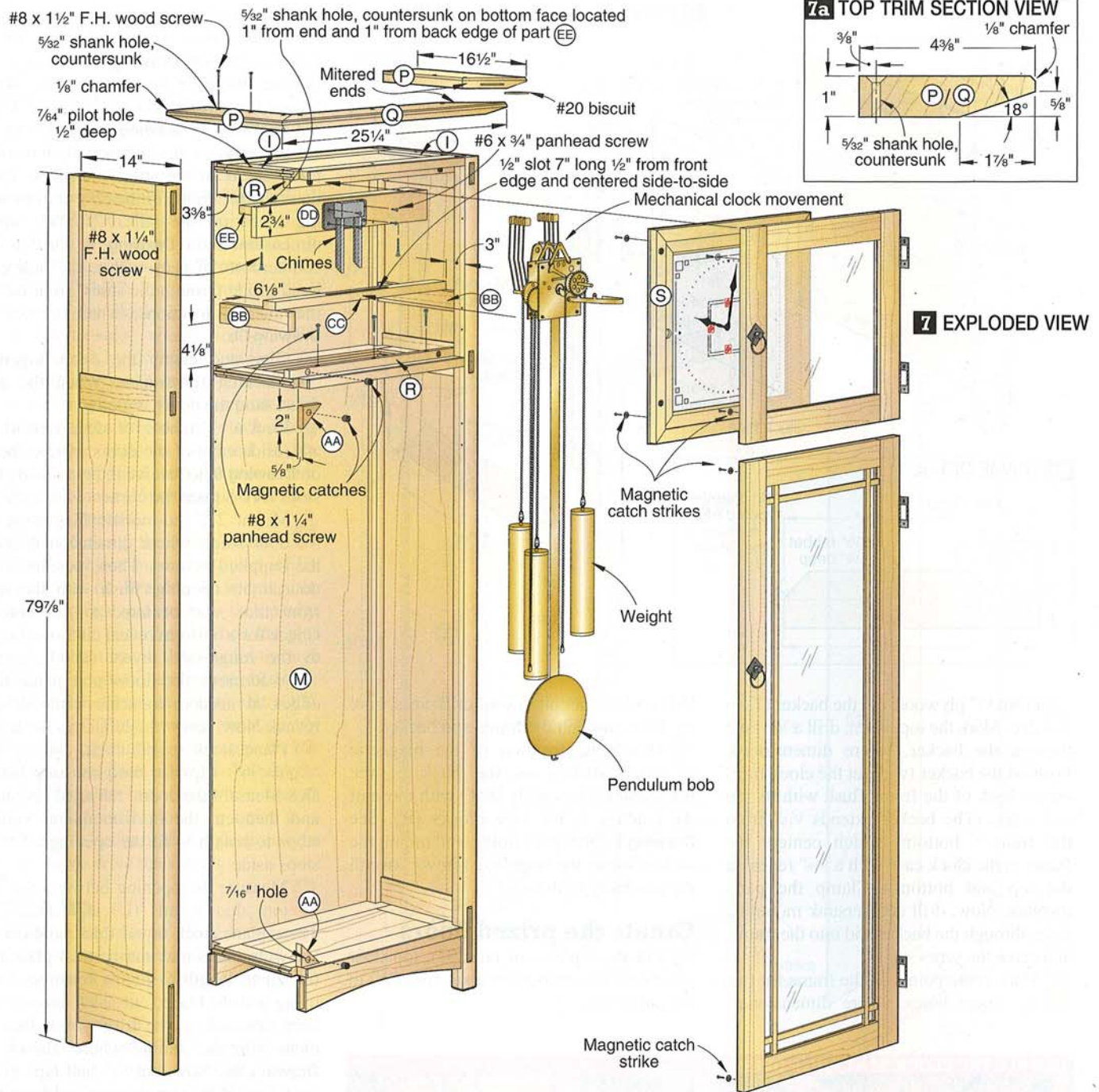

7 EXPLODED VIEW

place. Now, drill $\frac{7}{64}$ " pilot holes $\frac{1}{2}$ " deep centered in the shank holes into the top divider frame, and drive the screws.

Put on a beautiful face

1 Cut the face blocks (R) to size. Then, drill two $\frac{7}{16}$ " holes through the front edge, where dimensioned on **Drawing 4**, to receive magnetic catches, where shown on **Drawing 7**. (The catches hold the clock-face frame in place.) Now, drill $\frac{3}{16}$ " holes to form $\frac{3}{8}$ "-long slots through the top of the blocks, where dimensioned on **Drawing 4**. Using your vise, press magnetic catches into the $\frac{7}{16}$ " holes.

2 To mount the face blocks to the top of the middle divider frame's front stile (H) and to the bottom of the top divider frame's front stile, where shown on **Drawing 7**, position the blocks $\frac{1}{2}$ " back from the stiles' notches (the legs' back face), where dimensioned on **Drawing 4**. Clamp the blocks in place. Now, drill pilot holes, centered in the slots, into the stiles, and drive the panhead screws.

3 From $\frac{3}{4}$ "-thick stock, cut a $2\frac{1}{4} \times 78$ " workpiece for the frame members (S). Using your tablesaw, form a $\frac{1}{2}$ " rabbet $\frac{1}{4}$ " deep on the workpiece's front face, where dimensioned on **Drawing 8a**. Then,

using a 1"-tall auxiliary fence attached to the fence on your table-mounted router and positioning the workpiece on edge with the rabbeted surface against the fence, rout a $\frac{1}{4}$ " chamfer along the piece, where shown. Sand the workpiece smooth. Now, miter-cut four $17\frac{3}{8}$ "-long frame members from the piece. Glue, assemble, and clamp the frame together.

4 Mark centerpoints for two $\frac{7}{16}$ " holes in the frame for magnetic catches, where dimensioned on **Drawing 8**. (These catches hold the top door closed.) Using a Forstner bit, drill the holes. Now, install the catches.

8 CLOCK FACE FRAME ASSEMBLY

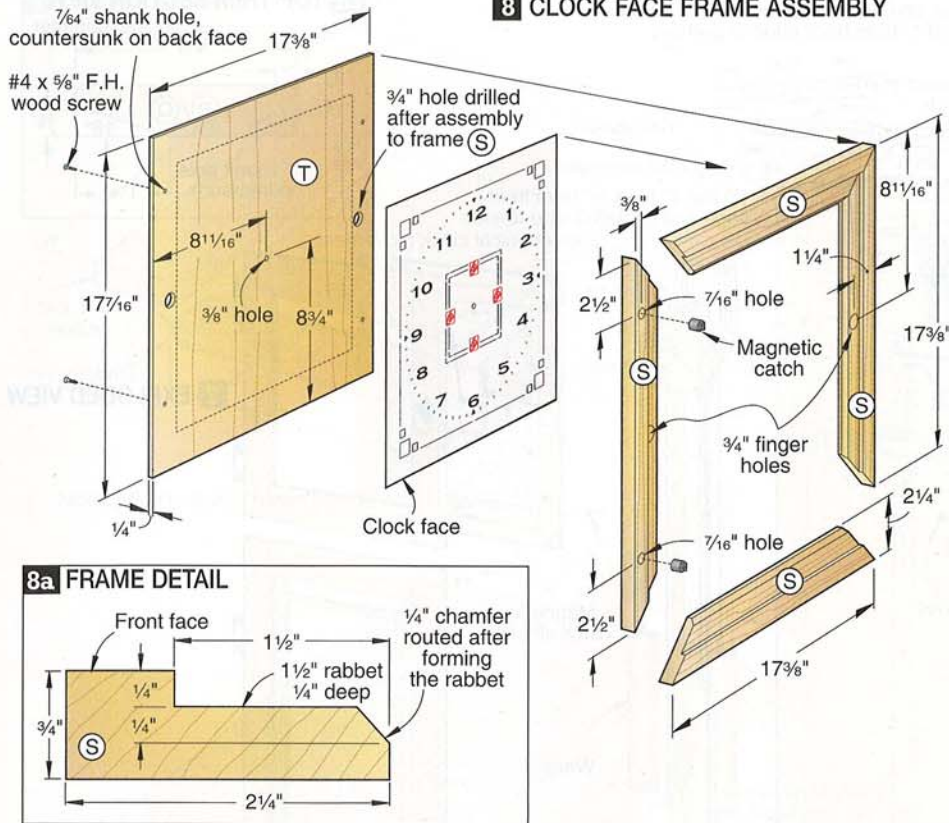

5 From $\frac{1}{4}$ " plywood, cut the backer (T) to size. Mark the top. Then, drill a $\frac{3}{8}$ " hole through the backer, where dimensioned. Position the backer (without the clock face) on the back of the frame flush with its top and sides. (The backer extends $\frac{1}{16}$ " from the frame's bottom, which centers the frame in the clock case with a $\frac{1}{16}$ " reveal at the top and bottom.) Clamp the parts together. Now, drill countersunk mounting holes through the backer and into the frame, and drive the screws.

6 Mark centerpoints on the frame for two $\frac{3}{4}$ " finger holes, where dimensioned.

Using a Forstner bit in your drill press, bore the holes through the frame and backer.

7 Match the location of the magnetic catch strikes on the back of the frame/backer assembly (S/T) with those of the catches in the face blocks (R). See **Drawing 7**. Drill pilot holes, and mount the strikes using the supplied screws. Install the assembly in the case.

Create the prized doors

1 Cut the top/bottom rails (U), top door stiles (V), and bottom door stiles (W) to the listed sizes.

2 Lay out $\frac{1}{4} \times \frac{1}{2}$ " mortises on the top and bottom door stiles (V, W), where dimensioned on **Drawing 9**. Using a $\frac{1}{4}$ " Forstner bit, drill the mortises $\frac{1}{16}$ " deep. Square them with a chisel.

3 Referring to **Drawing 9a**, cut tenons on the ends of the top and bottom door rails (U) to fit the stiles' mortises. Then, mark the locations for the door-pull mounting holes on the stiles (V, W), where dimensioned on **Drawing 9**. Drill a $\frac{1}{4}$ " counterbore $\frac{1}{4}$ " deep with a $\frac{3}{16}$ " hole centered inside through the stiles' front face at the marked locations, where shown on **Drawing 9b**.

4 Glue and clamp the doors together, checking for square. When the glue dries, sand the doors smooth.

5 Rout a $\frac{3}{8}$ " rabbet $\frac{3}{8}$ " deep around the inside edge of the doors, where shown on **Drawing 9**, to receive the glass and glass stops (X). Square the corners with a chisel.

6 Mount $2\frac{1}{2}$ " no-mortise hinges on the door stiles, where dimensioned, using the supplied screws. Then, position each door in its opening, flush with the legs' front face, and centered top to bottom. Check for a uniform reveal all around equal to the hinge-side reveal (approximately $\frac{3}{32}$ "). Remove the doors and plane their edges, if needed, to achieve the desired reveal. Now, screw the hinges to the legs.

7 Plane stock to $\frac{1}{4}$ " thick, and rip two $\frac{3}{8} \times 96$ " strips for the glass-stop blanks (X). Measure the doors' rabbeted openings, and then cut the horizontal and vertical stops to length to fit the openings. Set the stops aside.

8 Measure the opening between the bottom door's rails (U) and stiles (W). Then, plane stock to $\frac{1}{4}$ " thick, and cut the $\frac{1}{2}$ "-wide horizontal and vertical glass trim (Y, Z) to length to fit the opening. Next, using a dado blade, cut a $\frac{1}{4}$ " groove $\frac{1}{16}$ " deep centered on the trim's back face for clear silicone caulk, where shown on **Drawing 9c**. Now, cut $\frac{1}{2}$ " half-laps in the back face of the vertical trim and front face of the horizontal trim, where dimensioned on **Drawing 9**. Glue and clamp the trim together. When the glue dries, sand the assembly smooth.

9 Plane stock to $\frac{3}{8}$ " thick, and cut the door blocks (AA) to size, miter-cutting them, where shown on **Drawing 7**. Next, drill a $\frac{7}{16}$ " hole through the blocks, where shown. Then, install magnetic catches in the holes. Now, glue and clamp the blocks to the top of the bottom divider frame's front stile (H) and to the bottom of the middle divider frame's front stile, where dimensioned on **Drawing 4**. Match the location of the magnetic catch strikes on

INSTALL THE CLOCK SEAT AND MOVEMENT

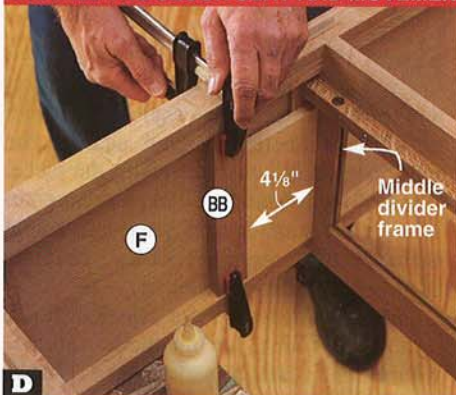

D Glue and clamp the cleats (BB) to the top side panels (F) using $4\frac{1}{8}$ "-wide spacers to position the cleats above the middle divider.

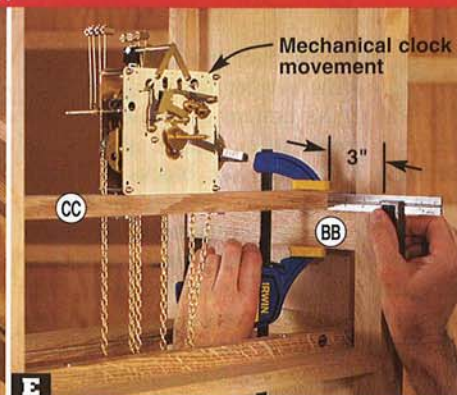

E Glue and clamp the clock seat (CC)/movement to the cleats (BB), locating the seat's front edge 3" back from the legs' front face.

the back face of the doors with the catches in the clock-face frame (S) and door blocks, and mount the strikes.

Time for the clock

1 Cut the cleats (BB), clock seat (CC), chime mount (DD), and chime-mount support (EE) to the listed sizes. Remove the frame/backer assembly (S/T). Then, install the cleats (BB) in the case against the top side panels (F), where dimensioned on **Drawing 7** and as shown in **Photo D**.

2 Cut a 1/2" slot 7" long 1/2" from the front edge of the clock seat (CC) and centered side-to-side, where shown. (We formed the slot by drilling 1/2" holes at the ends, and then scrollsawing it to shape.) Then, wearing cotton gloves to protect the brass, mount the mechanical clock movement on the seat, as directed in the instructions supplied with the movement. Now, install the seat/movement in the case, as shown in **Photo E**.

3 Glue and clamp the chime mount (DD) to the chime-mount support (EE), where shown on **Drawing 7**, keeping the support's top face and the mount's top edge as well as their ends flush. When the glue dries, drill countersunk shank holes through the support's bottom face, where shown.

4 Install the chimes on the mount (DD), as directed. Then, position the assembly in the case tight against the top divider frame with the back edge of the support (EE) 3 3/8" from the back (M), where shown. Using the support's mounting holes as a guide, drill 7/64" pilot holes 1/2" deep into the rails (I). Now, drive the screws.

Finish up

1 Remove the doors, clock movement, chimes, and hardware. Then, sand any areas that need it with 220-grit sandpaper. Remove the dust.

2 Apply a stain, if you wish. (We used Watco Danish Oil Finish, Dark Walnut, lightly sanding it when dry with 320-grit sandpaper.) Top-coat with a clear finish. (We applied three coats of AquaZar Water-Based Clear Satin Polyurethane, sanding to 320 grit between coats.)

Note: Let the finish dry for seven days before you install the clock movement because fumes will degrade the movement's lubricating oil, causing premature wear and mechanical problems.

3 Install the glass and glass stops (X) in the doors, where shown on **Drawing 9**, using #17x3/4" brads. To prevent splitting the stops, drill holes in them using a brad with its head snipped off.

4 Reinstall all of the hardware. Then, using the supplied screws, mount the

9 DOORS (viewed from back)

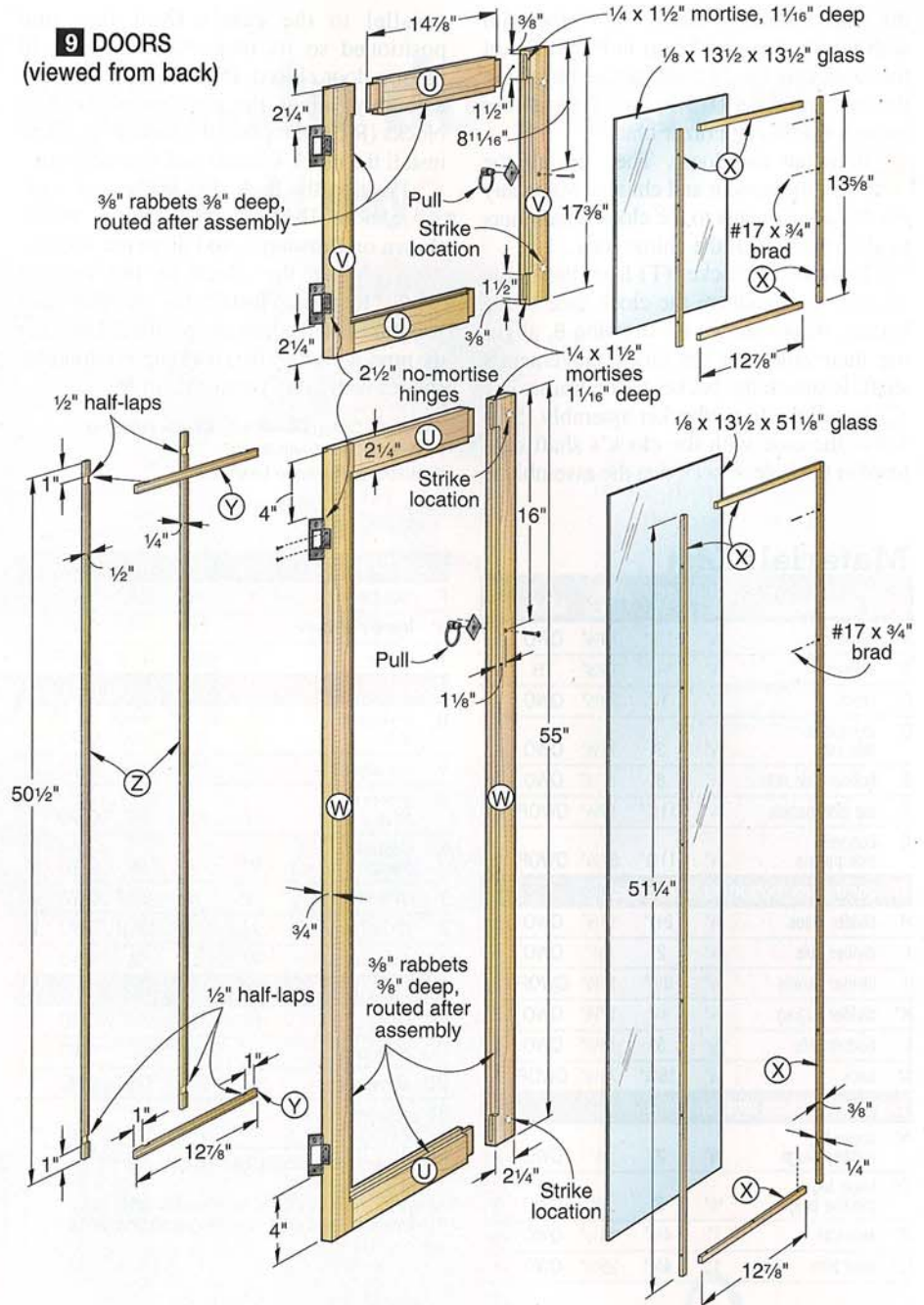

9a DOOR-RAIL TENON DETAIL

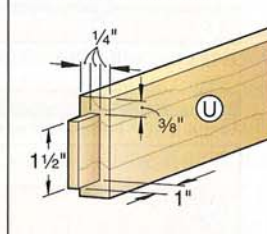

9b DOOR-PULL HOLE SECTION DETAIL

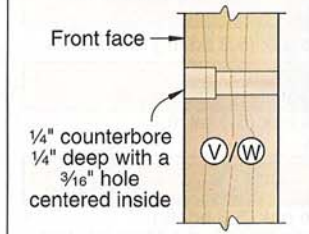

9c DOOR-TRIM DETAIL (viewed from back)

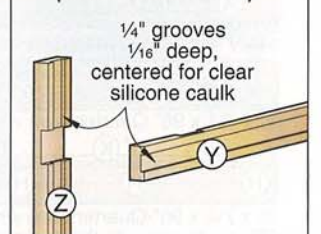

door pulls as shown on **Drawings 7** and **9**. Drive the supplied nails to secure the door-pull escutcheons.

5 To install the bottom door's trim assembly (Y/Z), first place the door faceup on

your workbench. Clean the glass. Then, to keep the long vertical trim (Z) straight, cut two 1x45" strips from 1/8" hardboard for spacers. Next, place a few dabs of clear silicone caulk in the 1/4" grooves in the back of

the trim assembly. Now, install the trim with the spacers, as shown in **Photo F**. Let the caulk cure for 24 hours before removing the tape and spacers. Trim any squeeze-out using a single-edge razor blade.

6 Remount the doors. Then, install the clock movement and chimes. Make any needed adjustments to the clock's hammers to align them with the chime rods.

7 Remove the backer (T) from the frame (S). Spray-adhere the clock face to the backer, where shown on **Drawing 8**, aligning their holes for the clock movement's shaft. Reattach the backer to the frame.

8 Install the frame/backer assembly (S/T) in the case with the clock's shaft centered in the hole. Check that the assembly is

parallel to the case's front face and positioned so its magnetic catches hold the top door closed. If needed, remove the assembly; adjust the position of the face blocks (R); and replace the assembly. Then, install the clock's hands and retaining nut.

9 Position the back (M) in the rear legs' rabbets. Drill mounting holes, where shown on **Drawing 3**, and drive the screws.

10 Move the clock to the desired location. Install the weights and pendulum, and adjust as specified. Now, set the time, and enjoy the charming Westminster chimes with every passing hour. 🕒

Written by **Owen Duvall** with **Chuck Hedlund**
Project design: **Kevin Boyle**
Illustrations: **Roxanne LeMoine**

INSTALL THE TRIM ASSEMBLY

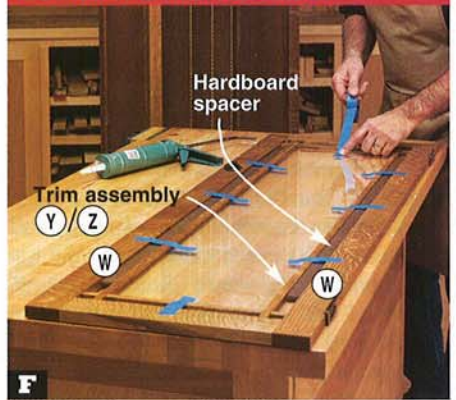

With the trim assembly (Y/Z) and spacers held tight against the glass and bottom door stiles (W), apply tape to hold the assembly in place while the caulk cures.

Materials List

Side assemblies	FINISHED SIZE			Matl.	Qty.
	T	W	L		
A* corners	3/4"	1 1/2"	79 7/8"	QWO	8
B* splines	1/8"	7 1/8"	79 7/8"	TH	4
C* fillers	3/4"	3/4"	79 7/8"	QWO	4
D top/middle side rails	3/4"	3"	11 1/2"	QWO	4
E bottom side rails	3/4"	6"	11 1/2"	QWO	2
F top side panels	1/4"	11 1/2"	14 3/8"	QWOP	2
G bottom side panels	1/4"	11 1/2"	52 1/4"	QWOP	2
Divider frames, bottom rails, and back					
H divider stiles	3/4"	2 3/4"	19 1/4"	QWO	6
I divider rails	3/4"	2"	8 1/2"	QWO	6
J divider panels	1/4"	8 1/2"	15 3/4"	QWOP	2
K* divider edging	1/4"	3/4"	17 1/2"	QWO	3
L bottom rails	3/4"	3"	18 1/2"	QWO	2
M back	1/4"	18 1/4"	74 7/8"	QWOP	1
Leg-mortise plugs and top trim					
N* upper leg-mortise plugs	1/2"	2"	3/8"	QWO	4
O* lower leg-mortise plugs	1/2"	5"	3/8"	QWO	2
P* side trim	1"	4 3/8"	16 1/2"	QWO	2
Q* front trim	1"	4 3/8"	25 1/4"	QWO	1

Clock face					
R face blocks	3/4"	3/4"	18 3/4"	QWO	2
S* frame members	3/4"	2 1/4"	17 3/8"	QWO	4
T backer	1/4"	17 3/8"	17 1/16"	QWOP	1
Doors					
U top/bottom rails	3/4"	2 1/4"	14 7/8"	QWO	4
V top door stiles	3/4"	2 1/4"	17 3/8"	QWO	2
W bottom door stiles	3/4"	2 1/4"	55"	QWO	2
X glass-stop blanks	1/4"	3/8"	96"	QWO	2
Y horizontal trim	1/4"	1/2"	12 7/8"	QWO	2
Z vertical trim	1/4"	1/2"	50 1/2"	QWO	2
AA door blocks	5/8"	2"	2"	QWO	2
Clock/chime supports and mounts					
BB cleats	3/4"	1 3/4"	11"	QWO	2
CC clock seat	3/4"	1 3/4"	19 1/4"	QWO	1
DD chime mount	3/4"	2 3/4"	18 3/4"	QWO	1
EE chime-mount support	3/4"	1 3/4"	18 3/4"	QWO	1

*Parts initially cut oversize. See the instructions.

Materials key: QWO—quartersawn white oak, TH—tempered hardboard, QWOP—quartersawn white oak plywood.

Supplies: Easy-release painter's tape; #20 biscuits; #4x5/8", #6x3/4", #8x1 1/4", and #8x1 1/2" flathead wood screws; #6x3/4" and #8x1 1/4" panhead screws; #17x3/4" brads; 1/8x13 1/2x13 1/2" glass (1); 1/8x13 1/2x5 1/8" glass (1); 1/8" hardboard; clear silicone caulk; spray adhesive.

Blades and bits: Dado-blade set; 1/4" brad-point bit; 45° chamfer and 3/8" piloted rabbeting router bits; 1/4", 7/16", and 3/4" Forstner bits.

Sources

Veneer. 1/4"-thick pressure-sensitive veneer, white oak quarter sliced, 24x96", no. 61332, \$59.99 (1). Call Rockler Woodworking and Hardware, 800/233-9359, or go to www.rockler.com.

Mechanical clock movement/hardware kit. Includes mechanical clock movement, chimes, clock face, magnetic catches with strikes and screws (6), door pulls (2), 2 1/2" no-mortise hinges (4). Order kit no. FC-04, \$338.95 ppd. Call Schlaubaugh and Sons Woodworking, 800/346-9663, or go to www.schsons.com.

Quartz clock movement/hardware kit. Includes battery-operated quartz chiming clock movement, pendulum drive, clock face, magnetic catches with strikes and screws (6), door pulls (2), 2 1/2" no-mortise hinges (4). Order kit no. FC-04Q, \$180.95 ppd. Call Schlaubaugh and Sons Woodworking, 800/346-9663, or go to www.schsons.com.

Lumber kit. Enough quartersawn white oak stock and plywood and tempered hardboard for one clock, kit no. W156, \$449.95 ppd. Heritage Building Specialties, call 800/524-4184, or go to www.heritagewood.com.

Cutting Diagram

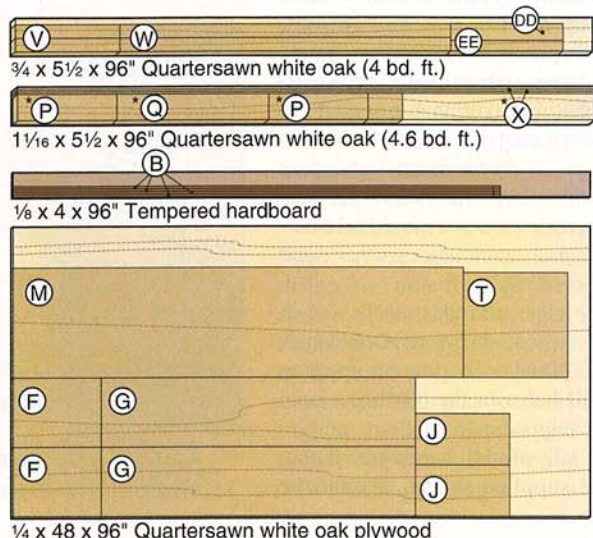
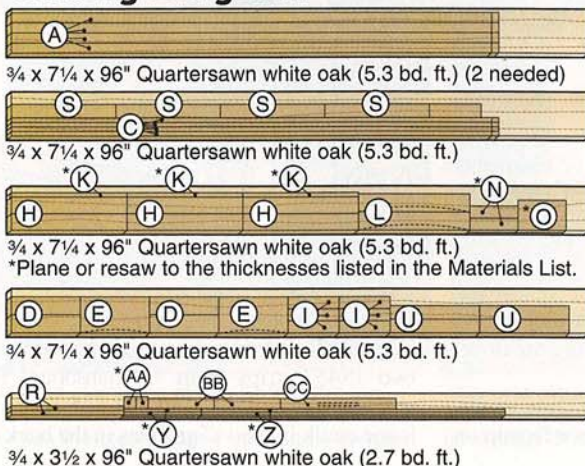

Two Ways...to do shelves

the old way...



ShopBot's way!



A tool to match your creativity

They're called CNC (Computer Numerically Controlled) tools in industry, where they do repeatable work. We call them Personal Robotic Tools (PRT) because they give you new skills and capabilities that are safe, efficient and fast! More than 3000 ShopBots have changed the way small shops do woodworking in more than 45 countries around the globe. They are used for everything from "weekend warrior" projects and crafts, to furniture manufacturing and production of aircraft components for the FA18. ShopBot's are ready for your shop, work areas range from 26"x32" to 5'x12' and larger.

ShopBot Goes a Step Beyond Servo's!

ShopBot's advanced new drive system gives you speed, performance and closed-loop dependability.

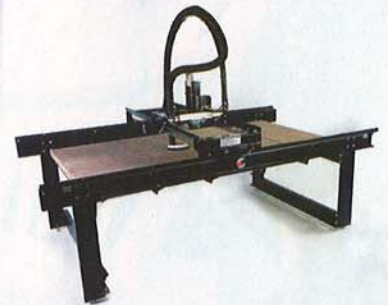

www.shopbottools.com

888-680-4466

ShopBot

Tools for tomorrow today!

VISIT WITH A MASTER

Sam Maloof

"The shape forces you back against the curved slats so the chair supports you from your shoulders all the way to the backs of your knees."

—Sam Maloof



Spend a day with America's quintessential chairmaker and learn a few tricks along the way.

An icon of American furnituremaking. An artist. A living legend. All of these words aptly describe Sam Maloof. But Sam shuns fancy labels in favor of a more fitting description. "I'm a woodworker," he says.

Though Sam has crafted more than 500 original furniture designs during five decades as a professional woodworker, his most famous piece remains his elegant, supremely comfortable rocking chair, seen at *left*. His chairs and other pieces are so uniquely original that they don't fit a particular furniture style, but have emerged instead as the "Maloof style."

Recently, we caught up with Sam in his Alta Loma, California, shop to see how this renowned woodworker creates his highly prized rockers that sell for \$20,000 and up. We quickly discovered that trying to derive a plan for one of Sam's chairs is comparable to getting a recipe from a chef that cooks with pinches and dabs: You probably won't be able to exactly re-create what he makes, but you can learn much about the craft by just observing.

Start with wonderful wood

Like all masters, Sam chooses his woods carefully and knows that beautiful lumber can separate a great piece from a good one. For many years, he built most of his pieces from walnut, which remains one of his favorite species thanks to its great workability and enduring good looks. He also often uses curly maple, zircote, and, on occasion, cherry. Many pieces also feature ebony accents.

Sam always keeps lumber on hand to ensure an adequate supply, and admits that



"I don't have to look for lumber, it finds me," Sam says. As a result, he needs four buildings to store his stash. Luckily, southern California offers ideal storage conditions: low humidity and moderate temperatures.

his passion for good wood may have gotten out of hand, as he now stores a few hundred thousand board feet of his favorites, all separated by species, thickness, and grain pattern, *below left*.

When the time comes to select wood for a chair, Sam carefully matches boards by color, especially when choosing walnut or cherry because they can have widely varying tones. Zircote and maple tend to be more consistent in color, so he selects them by carefully comparing and matching each board's distinctive grain.

Most of Sam's boards are thick, from 8/4 (2") through 16/4 (4"), because he cuts all chair parts except the rockers from solid stock, and many require large curves.

The rockers he creates from 1/4"-thick laminations glued on a form. This gives the rockers consistent shape and strength. Plus, bent lamination allows him to insert con-

trasting wood when desired, such as the ebony accent in the curly maple rocker seen at *left*.

Templates ensure success

Some woodworkers begin the building process by developing intricate plans for every dimension, part, and detail. Sam does not. Instead, he relies on templates, *below*, to give him the rough shapes needed for such parts as rockers, slats, and arms. Like his designs and techniques, he developed these templates using estimates and experience, not formal training.

"I made my original template for the back slats by cutting cardboard and holding it against my back, then reshaping it until it felt right," Sam says. "I've been using that template for over 30 years now. Everyone tells me how the chairs fit their backs just right, so I guess it works."

You won't find any jigs in Sam's shop, but you can't miss the plywood templates that hang everywhere space allows. Some are decades old, and still see regular use. Many bear the name of the original buyer of that style chair and provide a unique record of his clients.





BANDSAW SCULPTING WITH A MASTER'S TOUCH

Carefully eyeing his layout lines, Sam begins shaping the blank for a chair arm. He pivots and turns the arm as he works to follow the lines and create compound curves.

After about five minutes, Sam has transformed a rough blank into an arm that is ready for installation. He'll create the mirror image from the other blank, deftly matching the shapes as he works.

Sculpting the shapes

With his stock and appropriate templates in hand, Sam starts to rough out the parts at the bandsaw, a tool he has mastered like few other woodworkers, *above left*. He's quick to advise, though, that some of his methods "aren't exactly OSHA approved," and he knows better techniques exist. Regardless, he shapes chair parts with amazing agility, more sculpting than cutting. His templates give the rough shape. The rest he creates by eye and feel to make almost perfectly matched parts.

Forming the seat

To create a chair seat, Sam starts with five pieces of wood. When possible, he cuts them all from the same board to ensure the best color match.

He sculpts the seats to a shape that he believes lies at the heart of his chairs' comfort. "The shape forces you back and places you against the curved slats. This positions you so the chair supports you from your shoulders all the way to the backs of your knees," he says.

Beveling the edges of each seat board creates a contour that yields a more comfortable shape while requiring less shaping. Keeping the edges at 90° simplifies leg joinery.

Before gluing up the seat panel, Sam roughs out some of this sculpted shape at the bandsaw. The seats he makes today feature beveled edges on each of the boards, as seen *below*. This design allows deeper hollowing of the surface than was possible with the flat seat panels he used to make. Though today's chairs look similar to those made decades ago, these subtle refinements point to Sam's drive to constantly improve.

The joint Sam uses to join the seat and legs stands as another of those refinements made over many years. You can see this joint, which he calls the dado-and-rabbet, in the drawing and accompanying photo on the *following page*. "I spent four or five years developing that joint," he notes.

Though the joint offers loads of glue surface, Sam reinforces it with screws after assembling it with standard yellow glue. He's tried many types of screws over the years, and these days chooses ones designed for deck building because of their deep thread purchase. Some woodworkers may scoff and say deck screws aren't appropriate in fine furniture, but Sam sees it differently. He wants to ensure his chairs remain together.

He covers the screws with plugs which he used to make from the same wood as the chair. Now, plugs are often made of ebony. Screws also reinforce the rocker-to-leg joint. Where the arms meet the front legs, blind dowels (no screws) provide strength.

ANATOMY OF A MALOOF ROCKER SEAT

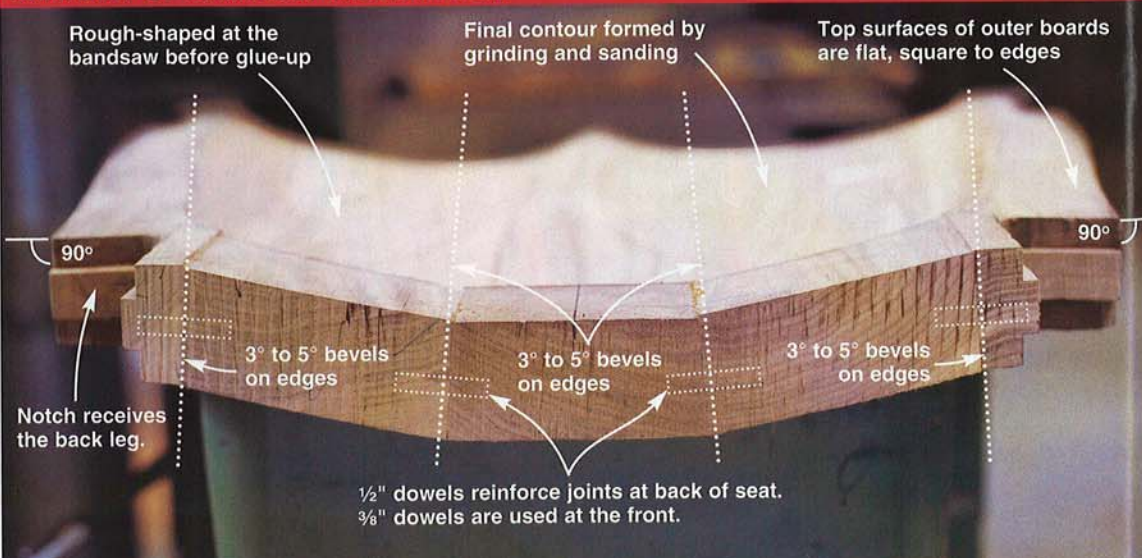

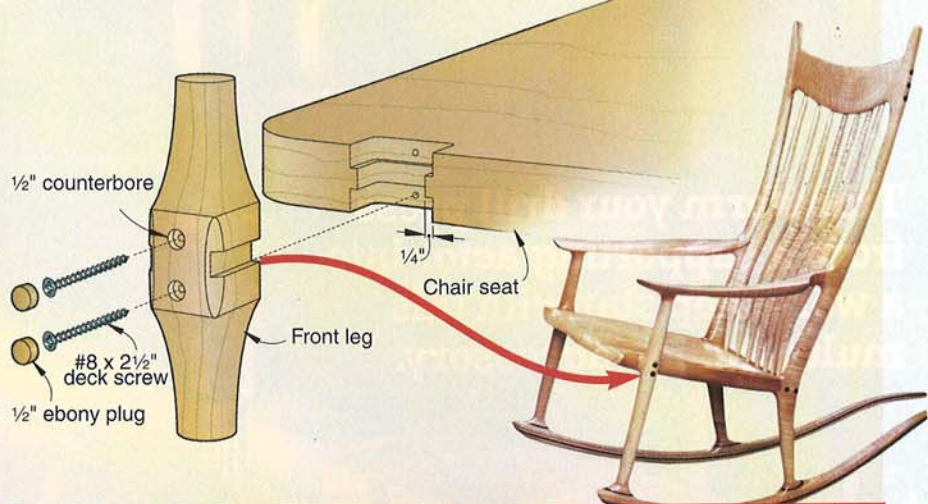

THE DADO-AND-RABBET JOINT

This unique joint attaches the front and back legs to the seat. The pieces interlock to form a twist-resistant joint with lots of glue surface. A couple of screws, covered by plugs, add strength to withstand long-term use. After assembly, rasps and files blend all the surfaces together.

Handwork yields final form

For most woodworkers, final assembly of a project means the work is almost complete. With Sam's chairs, though, much work remains. Why? At assembly, all pieces still hold only their rough shape. To create seamless joints and crisp details, Sam relies on hours of painstaking shaping. Pneumatic sanders and grinders speed this process, but most of the work gets done using just traditional hand tools, such as those seen below.



Traditional hand tools get a workout in Sam's shop. Sam and the boys commonly use rasps, files, riflers, sandpaper, and scrapers to refine the rough shapes into finished form.

This phase of the process takes many hours, which in the early years meant Sam could produce very few pieces annually. So, Sam employs talented craftsmen who get little of the glory, but play essential roles which Sam readily acknowledges. Seen in the photos, right, "the boys," as Sam calls them, are like sons. All three have been with him for at least 15 years.

During this shaping process, the chairs pass continually back and forth among all four guys. Because the process takes much time and because there are usually multiple chairs in process simultaneously, a month may pass before any one chair makes its way from beginning to end.

Once Sam approves the workmanship, a chair is ready for finishing. After sanding to at least 400 grit, a chair gets multiple coats of the finishes Sam developed. The first consists of equal parts boiled linseed oil, tung oil, and polyurethane varnish. Sam applies at least three liberal coats, allowing each to dry for a day. After the third coat, a second mixture of linseed oil, tung oil, and carnauba wax gets applied. Rubbing vigorously ensures that these coats blend thoroughly into those underneath. Again, he applies three coats over three days.

For many years, Sam brewed the finishes himself, but he now has them manufactured. You can purchase Sam's finishes through Rockler Woodworking and Hardware at www.rockler.com or 800/279-4441. A quart of either the poly/oil blend (#58644) or oil/wax blend (#58677) sells for \$15.99.

Finally, each chair receives a couple of coats of furniture wax. The multistep finish imparts a rich glow and adds depth to the grain figure. And, it holds up well, taking on a warm patina over years.

Sam's legacy and his future

Even at 88 years young, Sam works six days per week designing, cutting out, and assembling every piece of furniture. He also designs a few new pieces each year. "I love being in the shop. It's what I do," he says.

In addition, he established the Sam and Alfreda Maloof Foundation and devised a plan that will pass his business on to the boys; his son, Slimen; new wife, Beverly; and his business manager, Roz Bock.

So, does he have unfulfilled ambitions? Sure, but he keeps it all in perspective: "If I ever make it to the top of the mountain, there will be nowhere to go but back down. So I just keep climbing."

Learn more about Sam by reading *Sam Maloof, Woodworker*, or *The Furniture of Sam Maloof*. Both of these books are available from Amazon.com. Or you can visit malooffoundation.org where you'll find more information on Sam's business and schedules for public shop tours. ♣

Written by David Stone
Photographs: Edmund Barr

THE BOYS: SAM'S PARTNERS IN FURNITUREMAKING HEAVEN

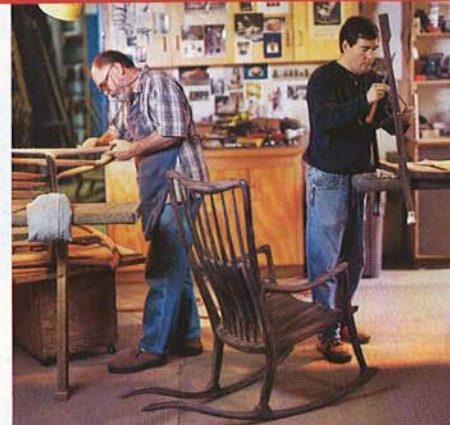
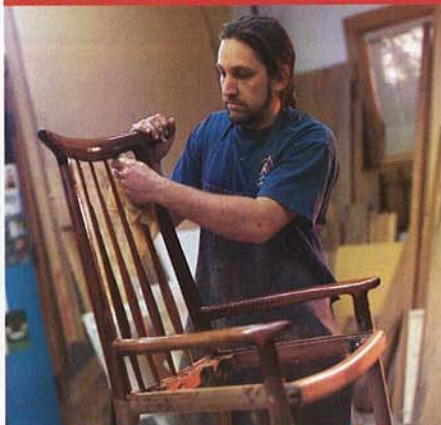

David Wade, left, applies Sam's special finish to a decades-old chair sent in for refurbishing, while Larry White, middle, and Mike Johnson shape new chairs still under construction.

Transform your drill press from a supporting actor into a workshop star with this multifunction accessory.

Hold-downs quickly and securely clamp workpieces for safe, accurate drilling.

The 3"-high, 32"-long fence slides forward and back, and locks in place in seconds.

A sliding, micro-adjustable stopblock ensures dead-on, repeatable positioning.

Generous 14½×29½" table eases handling of large workpieces.

feature-packed drill-press table

PULL-OUT FENCE EXTENSIONS

Lockable pull-out extensions add 9½" to each end of the fence.

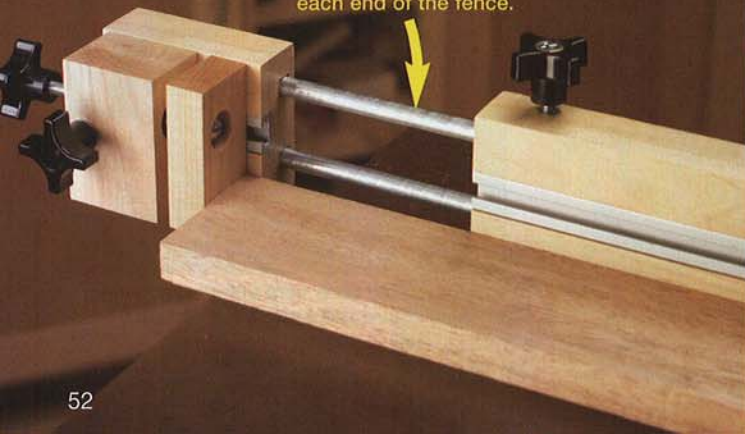

REPLACEABLE TABLE INSERT

A replaceable insert provides full workpiece support when drilling or sanding.



Although indispensable in a wood-working shop, most drill presses come equipped with a table more suited to metalworking. This add-on table with fence sets things straight, supplying everything the cast-iron table on your drill press lacks.

Start with the table

1 For the base (A), cut two $14\frac{1}{2} \times 29\frac{1}{2}$ " pieces of $\frac{1}{2}$ " plywood. (We used Baltic birch plywood for its flatness and absence of voids. You also can use regular birch plywood or medium-density fiberboard.) Glue and clamp the pieces together, keeping their ends and edges flush, where shown on **Drawing 1**.

2 From $\frac{1}{4}$ " tempered hardboard, cut the top sides (B), top front (C), and top back (D) to the sizes listed in the **Materials List**. Mark the $\frac{3}{8}$ "-radius finger notch on the front edge of part D, where shown on **Drawing 1**. Cut and sand it to shape. [The notch makes it easy to remove the insert (E).] Now spread glue on the backs of the hardboard top parts, and glue and clamp them to the 1"-thick plywood base, as shown in **Photo A**.

3 Draw the $\frac{3}{4}$ "-radius cutout at the rear of the table, where shown on **Drawing 1**. Bandsaw or jigsaw and sand it to shape.

4 To locate the $3\frac{1}{2} \times 3\frac{1}{2}$ " cutout in the add-on table base, install a $\frac{1}{8}$ " bit in the drill-press chuck, center your metal drill-press table under the bit, and lock the table in place. Position the add-on table to center the bit in the recess for the insert (E) created by parts B, C, and D. If the metal drill-press table protrudes beyond the front edge of the add-on table, slide the add-on table forward until the two are flush. Clamp the add-on table in place. Now drill a $\frac{1}{8}$ " hole all the way through the base (A). Remove the add-on table, and turn it upside down. Mark the $3\frac{1}{2} \times 3\frac{1}{2}$ " cutout centered on the $\frac{1}{8}$ " hole. Then drill $\frac{3}{8}$ " holes at the corners, and cut the opening with a jigsaw. Now cut the insert (E) to the size listed.

5 For a drill press with slots through its metal table, cut the groove for the mini-track in the bottom of the add-on table where shown on **Drawing 1**.

For a drill press without slots in its metal table, drill two $\frac{1}{4}$ " mounting holes. Locate the holes about halfway between the center of the table and its rear edge and as far apart as possible. Then clamp the add-on table in place as before, and trace the hole locations on its bottom. Cut the groove for the mini-track so it passes over the hole locations.

6 Turn the table over, and cut dados for the top mini-tracks, where shown on

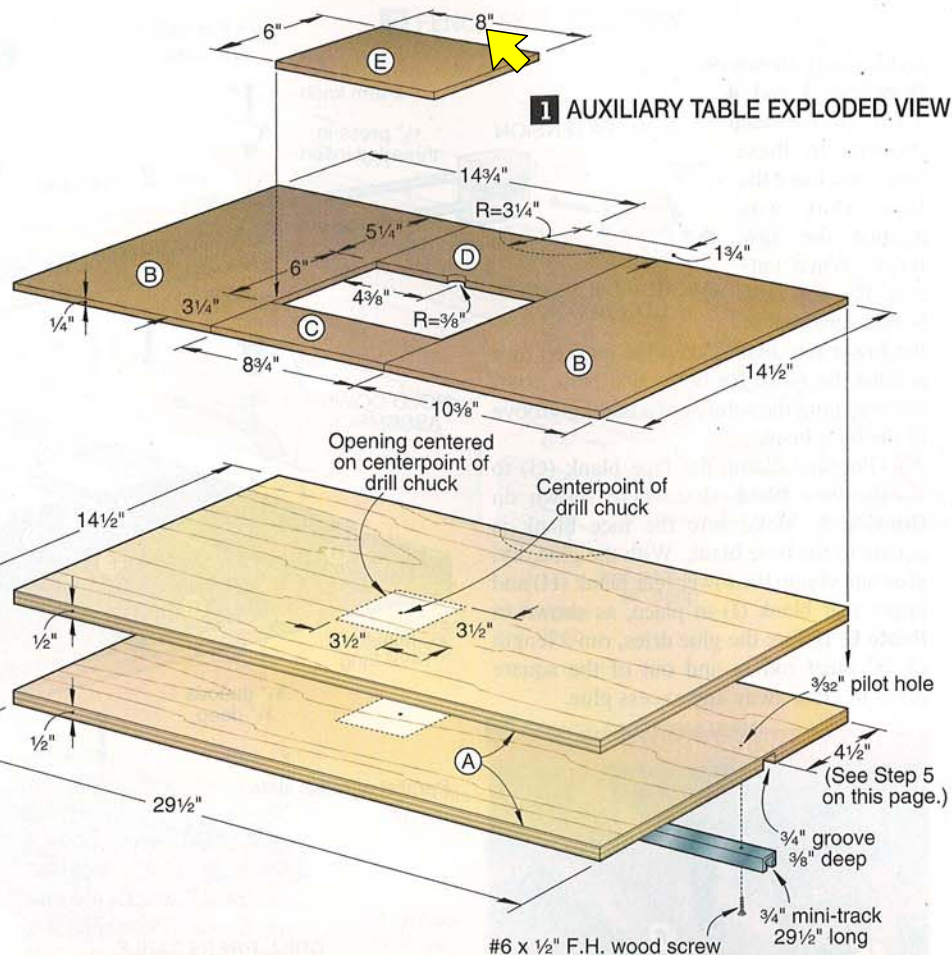

GLUING UP THE TABLE

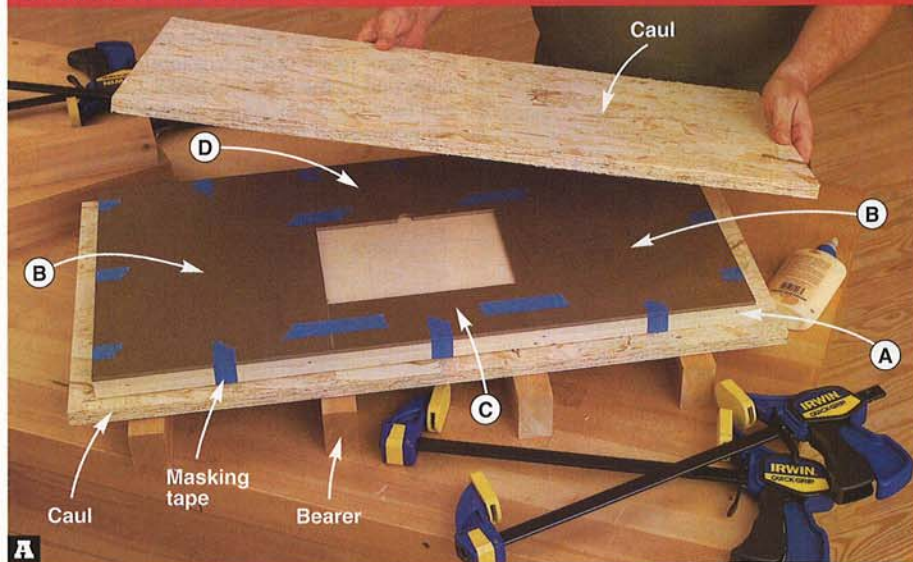

With glue applied to their bottom surfaces, position top parts B, C, and D on the 1"-thick base (A). To keep them from shifting, tape the top parts to each other and to the base with masking tape. Then clamp the top and base between $\frac{3}{4}$ "-thick cauls and 2x3 bearers.

Drawing 2. (The dados are centered on the joint lines between the parts B and the parts C and D.)

Note: To add under-table dust collection for the sanding-drum setup shown in the photo, near left, see page 16.

Now make the fence

1 Cut the base blank (F), face blank (G), lower rear blank (H), and upper rear blank (I) to size. Install a $\frac{3}{8}$ " dado blade in your tablesaw and position the fence to cut centered grooves in the thickness of parts H

and I, where shown on

Drawings 3 and 4.

Then cut 3/16"-deep grooves in these parts, and mark the face that was against the saw fence. When cutting the top and bottom grooves in

the lower rear blank, keep the marked face against the fence for both cuts. Now without changing the setup, cut a mating groove in the base blank.

2 Glue and clamp the face blank (G) to the base blank (F), where shown on **Drawing 4**. Make sure the face blank is square to the base blank. With the glue dry, glue and clamp the lower rear blank (H) and upper rear blank (I) in place, as shown in **Photo B**. Before the glue dries, run a length of 3/8" steel rod in and out of the square holes to clear away any excess glue.

MAKING THE FENCE

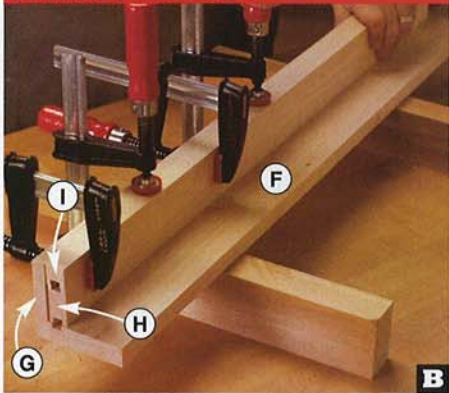

2 EXPLODED VIEW

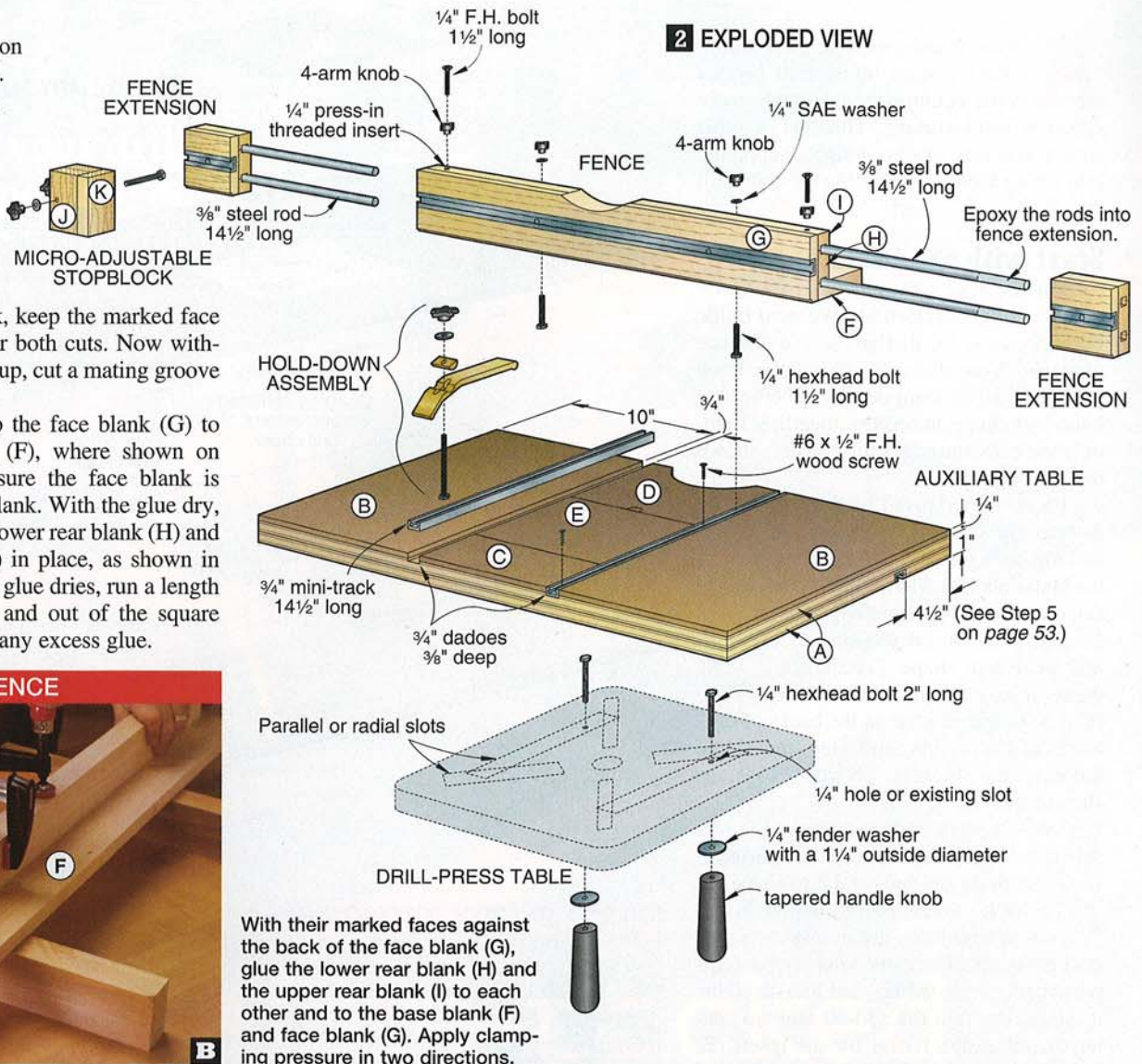

With their marked faces against the back of the face blank (G), glue the lower rear blank (H) and the upper rear blank (I) to each other and to the base blank (F) and face blank (G). Apply clamping pressure in two directions.

Tips on using threaded inserts

Shop fixtures and jigs often require the installation of various clamping or adjustment knobs. That's when you'll reach for threaded inserts. Commonly available in sizes from #8-32 (a #8 screw body with 32 threads per inch) to 3/8"-16 (a 3/8" screw body with 16 threads per inch), there are two basic types: thread-in and press-in, shown at *near right*.

Use thread-in inserts in softer woods and plywood where their coarse outside threads cut easily into the surrounding wood. Simply drill a hole sized for the body of the insert, and screw it into place. In very hard woods, such as white oak and maple, or when the insert is close to the edge of a part and screwing it in may split the wood, drill a hole slightly larger than the outside thread diameter, and epoxy the insert in place. To protect the

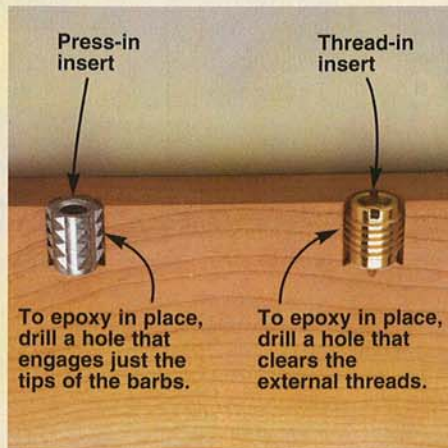

internal threads from epoxy, cover the end of the insert, as shown *above right*.

Press-in inserts, with their barbed exteriors, work well in hard woods, soft woods, and plywood. Drill a hole sized for the body of the insert, and press it into place with a clamp or tap it in with a hammer

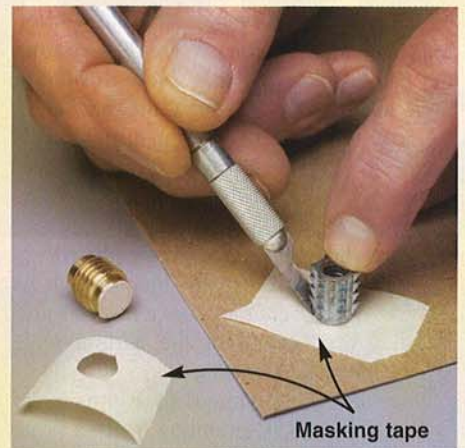

and a block of wood. For applications in which the clamping action tends to push the insert out of the wood, such as the knobs that tighten down on the drill-press fence extension rods, drill a hole that engages just the tips of the insert barbs and epoxy it in place.

3 Cut a $\frac{3}{4}$ " groove $\frac{3}{8}$ " deep for the mini-track in the fence face (G), where shown on **Drawing 4**. Then cut a $\frac{1}{8} \times \frac{1}{8}$ " sawdust-relief rabbet along the bottom edge of the fence face.

4 Trim one end of the assembled fence blank square, and then cut it into three pieces, where shown on **Drawing 3**, making a $22\frac{1}{2}$ "-long fence and two $3\frac{1}{2}$ "-long extensions. Now cut off the base portions of the extensions, where shown on **Drawing 4**.

5 Bending a fairing strip to join their endpoints and centerpoints, mark the centered radius cutouts on the top of the fence and the back of its base (F), where shown on **Drawing 3**. Bandsaw or jigsaw, and sand them to shape. Then drill $\frac{1}{4}$ " holes for the bolts that hold the fence to the table and a hole for the drill-press chuck key in the fence base, where shown.

6 To install press-in threaded inserts in the fence portion of part I, drill $\frac{7}{16}$ " holes to intersect the top square hole in the fence, where shown on **Drawings 3** and **4**. Spread epoxy in the holes, and press the inserts in place. When the epoxy cures, ream out any excess that may have dripped into the extension rod holes with a $\frac{3}{8}$ " drill bit. For more information on using threaded inserts, see the sidebar, *opposite*.

Finish and assemble the table and fence

1 Cover the bottoms of the grooves and dadoes for the mini-track in the table and fence with masking tape. Now apply a clear finish to all the parts. (We used two coats of satin polyurethane, sanding between coats with 220-grit sandpaper.) When the finish dries, remove the masking tape.

2 Using the countersunk holes in the mini-track as guides, drill pilot holes into the mating table and fence parts. (The mini-track supplied with the hardware kit listed in **Sources** on page 56 comes cut to the needed lengths.) Apply epoxy to the bottoms of the grooves and dadoes, and screw and clamp the mini-track in place.

*Note: The mini-track has a small flange along one outside edge, where shown on **Drawing 4**. To make certain the track in the fence aligns with the track in the exten-*

sions, orient the flange in the same direction in all three parts.

3 Cut four $14\frac{1}{2}$ "-long pieces of $\frac{3}{8}$ " steel rod with a hacksaw. Using 80-grit sandpaper, rough up $3\frac{1}{2}$ " at one end of each rod, and epoxy these ends into the square holes in the fence extensions. To hold the rods parallel while the epoxy cures, insert their other ends into the square holes in the fence.

4 To make knobs for locking the fence extensions in place, refer to **Drawing 2**, and thread $1\frac{1}{2}$ "-long flathead bolts partway into a pair of four-arm knobs. Apply epoxy under the heads, and then seat the bolts in the knobs.

5 Referring to **Drawing 2**, slide the heads of two hexhead bolts into the auxiliary table bottom mini-track. Position the auxiliary table on the drill-press table, dropping the bolts into the slots or holes. Add washers and thread on the tapered handle knobs. *Note: The tapered handle knobs accept about $\frac{5}{8}$ " of bolt length. You may need to trim the 2"-long hexhead bolts to accommodate the thickness of your drill-press table.*

6 Slide hexhead bolts into the auxiliary table top mini-tracks. Align the holes in the fence base with the bolts, drop on flat washers, and fasten the fence with four-arm knobs. Slide the extension rods into the fence, and thread in the locking knobs.

$\frac{1}{4}$ " press-in threaded insert, epoxied into place

3 FENCE EXPLODED VIEW

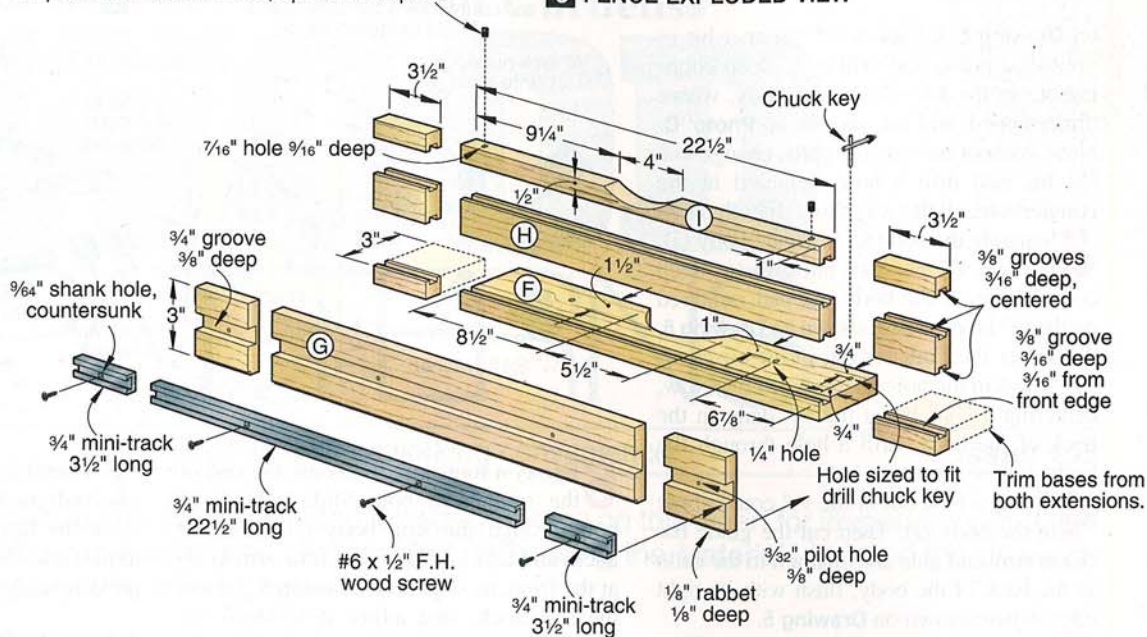

4 FENCE SECTION VIEW

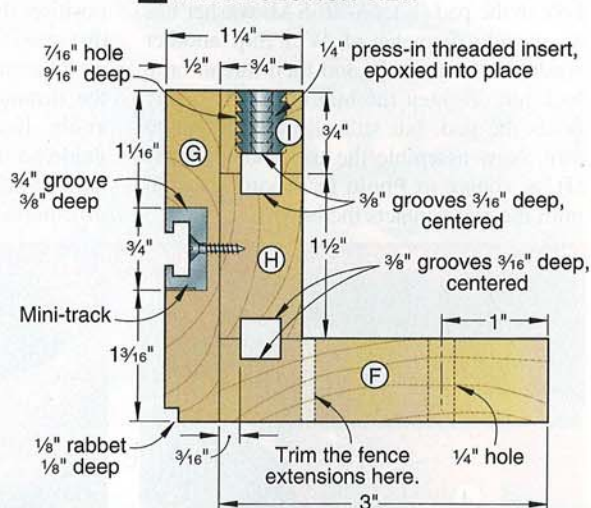

Add an adjustable stopblock

1 To form the body (J), cut two pieces of $\frac{3}{4}$ " stock to $2 \times 2\frac{1}{8}$ ", and glue them together face-to-face, keeping their ends and edges flush. With the glue dry, cut a $\frac{1}{4}$ " dado $\frac{3}{16}$ " deep centered in the back of the body, where shown on **Drawing 5**.

2 Cut the pad (K) to size, and adhere it with double-faced tape to the right side of the body (J) in the configuration shown

on **Drawing 5**. Chuck a 1/2" Forstner bit in your drill press, and drill a 3/8"-deep counterbore in the left side of the body, where dimensioned and as shown in **Photo C**. Now, without moving the parts, change to a 1/4" bit, and drill a hole, centered in the counterbore, all the way through both parts.

3 Separate the pad (K) from the body (J). Using a 3/4" Forstner bit, drill 3/8"-deep counterbores in the body and pad, centered on the 1/4" holes, where shown on **Drawing 5**. To center the Forstner bit, insert pieces of 1/4" dowel in the holes before drilling. Now, centering a 17/64" bit in the 1/4" dado in the back of the body, drill a hole through the body, where shown.

4 Epoxy a lock nut in the 1/2" counterbore in the body (J). Then cut the guide bar (L) to size, and glue and clamp it in the dado in the back of the body, flush with its right edge, where shown on **Drawing 5**.

5 Apply a clear finish to the parts. With the finish dry, slip a 1/4" SAE washer onto the roundhead bolt, and insert it in the hole in the pad (K). (A 1/4" SAE washer has an outside diameter of 5/8".) Slip another washer onto the bolt, and then thread on a lock nut. Tighten the lock nut so it firmly holds the pad, but still allows the bolt to turn. Now assemble the pad and the body (J), as shown in **Photo D**, driving the bolt until the pad contacts the body.

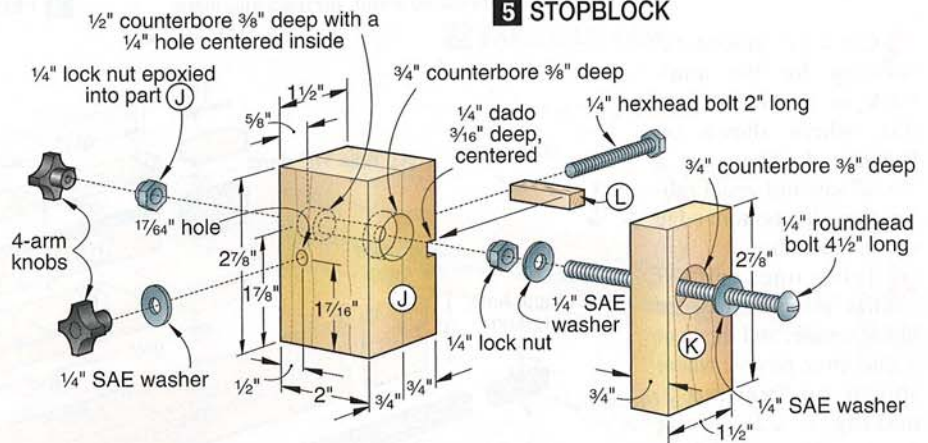

6 Epoxy a four-arm knob onto the end of the roundhead bolt. Slide a hexhead bolt through the stop body (J) from the back, and add a washer and four-arm knob at the front, as shown on **Drawing 5**. To use the stopblock, first adjust it to leave 1/2" between the pad (K) and the body. Slide the guide bar and the bolt hexhead into the mini-track, using a ruler or tape measure to position the stopblock close to the desired distance from the drill bit. Clamp it in place by tightening the front knob. Now fine-tune the distance to the bit by turning the end knob. Because the clamping knob and guide bar (L) are centered in the stopblock body, you can use it on either side of the drill-press chuck by simply turning it over.

7 Assemble the hold-down clamps in the configuration shown on **Drawing 2**. Slide the hexheads of their bolts into the mini-track. Now your *woodworking* drill press is ready for action. 🌲

Written by **Jan Svec**
Project design: **Jeff Mertz**
Illustrations: **Roxanne LeMoine**

Materials List

Table	FINISHED SIZE			Matl.	Qty.
	T	W	L		
A base	1"	14 1/2"	29 1/2"	LP	1
B top sides	1/4"	10 5/8"	14 1/2"	H	2
C top front	1/4"	3 1/4"	8 3/4"	H	1
D top back	1/4"	5 1/4"	8 3/4"	H	1
E insert	1/4"	6"	8"	H	1
Fence					
F base blank	3/4"	3"	32"	M	1
G face blank	1/2"	3"	32"	M	1
H lower rear blank	3/4"	1 1/2"	32"	M	1
I upper rear blank	3/4"	3/4"	32"	M	1
Stopblock					
J body	1 1/2"	2"	2 7/8"	LM	1
K pad	3/4"	1 1/2"	2 7/8"	M	1
L guide bar	1/4"	3/8"	1 1/8"	M	1

Materials key: LP—laminated plywood, H—tempered hardboard, M—maple, LM—laminated maple.

Supplies: Masking tape, double-faced tape, 1/4" dowel, epoxy.

Blades and bits: Stack dado set; 1/2" and 3/4" Forstner bits.

Sources

Hardware kit. #6x1/2" flathead wood screws (12); 3/4" mini-track: 29 1/2" long (1), 14 1/2" long (2), 22 1/2" long (1), and 3 1/2" long (2); 1/4" press-in threaded inserts (2); 3/8" steel rod 14 1/2" long (4); 1/4" flathead bolts 1 1/2" long (2); 1/4" roundhead bolt 4 1/2" long (1); 1/4" hexhead bolts: 1 1/2" long (2), 2" long (3); 1/4" SAE flat washers (5); 1/4" lock nuts (2); four-arm knobs (6); tapered handle knobs (2); 1/4" IDx1 1/4" OD fender washers (2); hold-down assemblies (2). Kit no ADP-1, \$42.95 plus \$7.95 shipping. Schlabaugh & Sons Woodworking. Call 800/346-9663, or order online at schsons.com.

Sheet goods kit. Two 1/2x14 1/2x29 1/2" pieces of Baltic birch plywood and one 1/4x15 3/4x31 3/4" piece of tempered hardboard. Kit no. LP-6, \$15.95 ppd. See above for telephone number and Web address.

DRILL AND ASSEMBLE THE STOPBLOCK

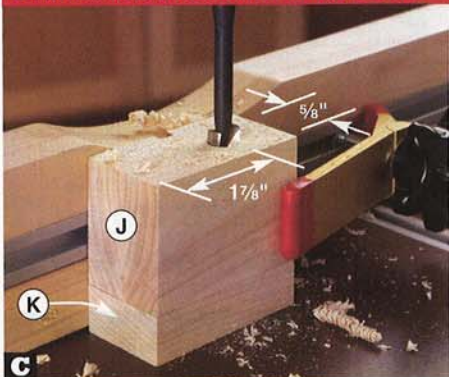

With the pad (K) down and the dadoed back of the body (J) against the fence, clamp the parts in place, and drill a 1/2" counterbore 3/8" deep in the side of the body.

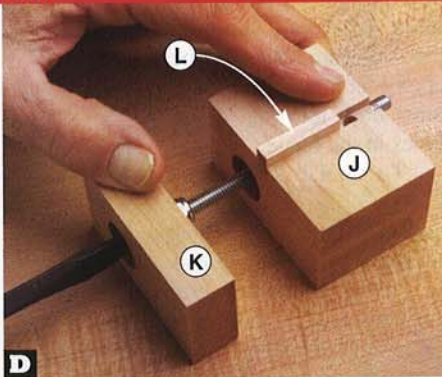

With the pad (K) mounted on the bolt with washers and a lock nut, slide the bolt into the stop body (J), and drive it into the lock nut epoxied in the body.

Cutting Diagram

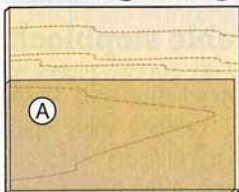

1/2 x 24 x 30" Baltic birch plywood (2 needed)

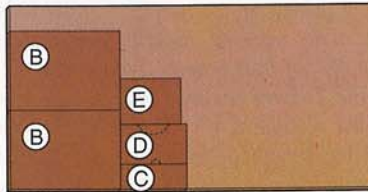

1/4 x 24 x 48" Hardboard

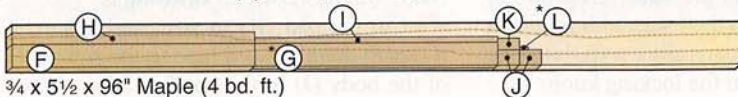

3/4 x 5 1/2 x 96" Maple (4 bd. ft.)

*Resaw and plane to the thicknesses listed in the Materials List.

Better Homes and Gardens®

WOOD PATTERNS

June/July 2004

For your woodworking convenience

Issue 156

Dear Reader: As a service to you, we've included full-size patterns on this insert for irregular-shaped and intricate project parts. You can machine all other project parts using the Materials List and the drawings accompanying the project you're building.

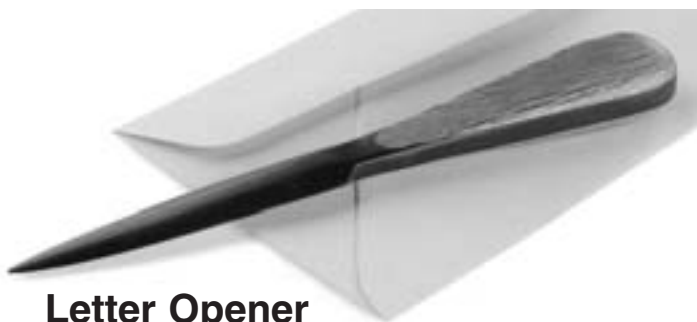

Letter Opener
Page 65



Mallet Page 96

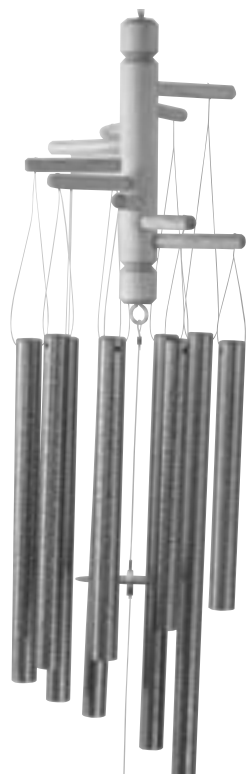

Wind Chimes
Page 94



Garden Bench Page 74

Wind Chimes Page 94

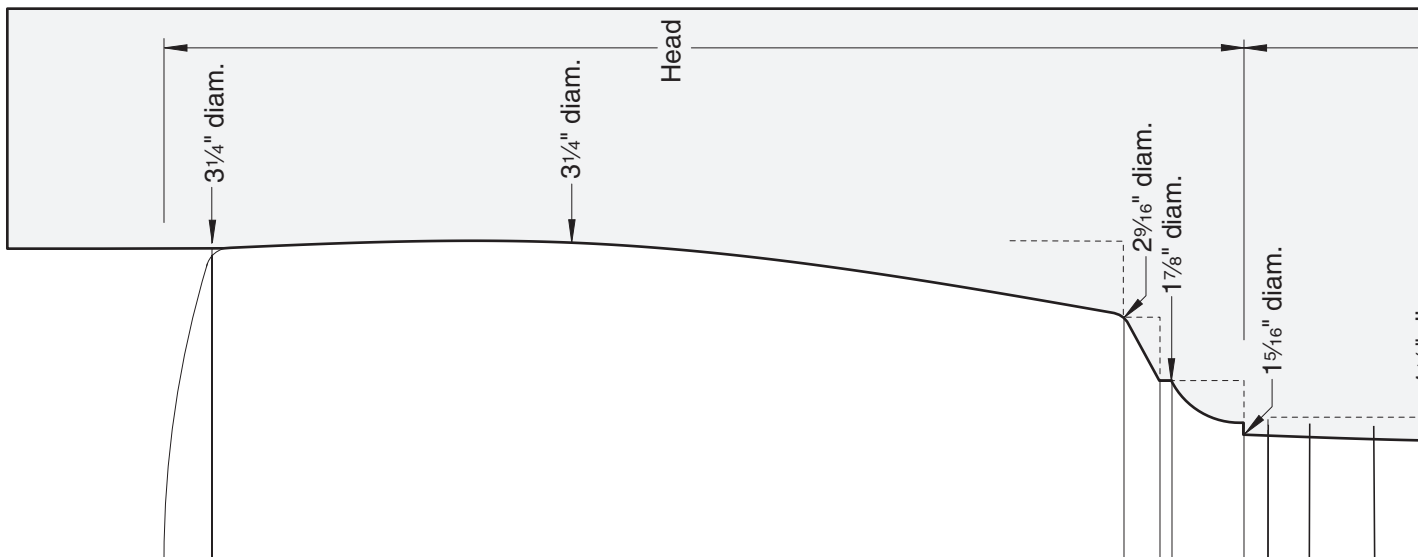
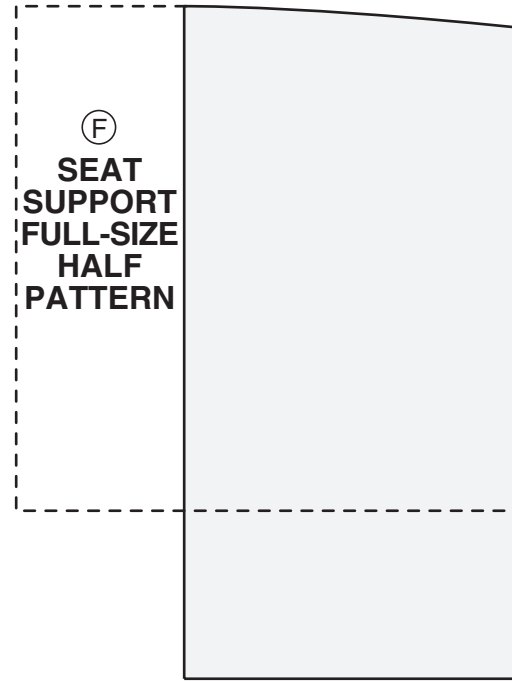
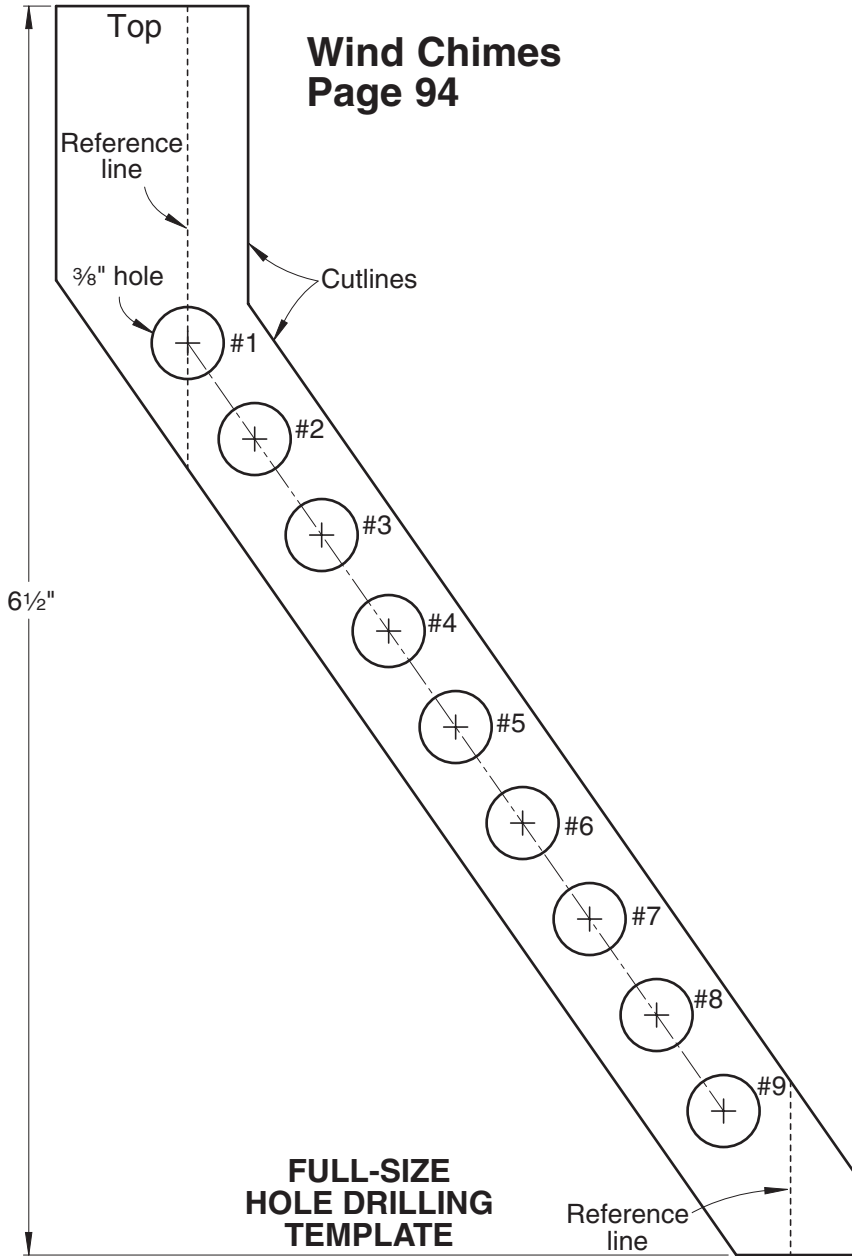

**Garden Bench
Page 74**

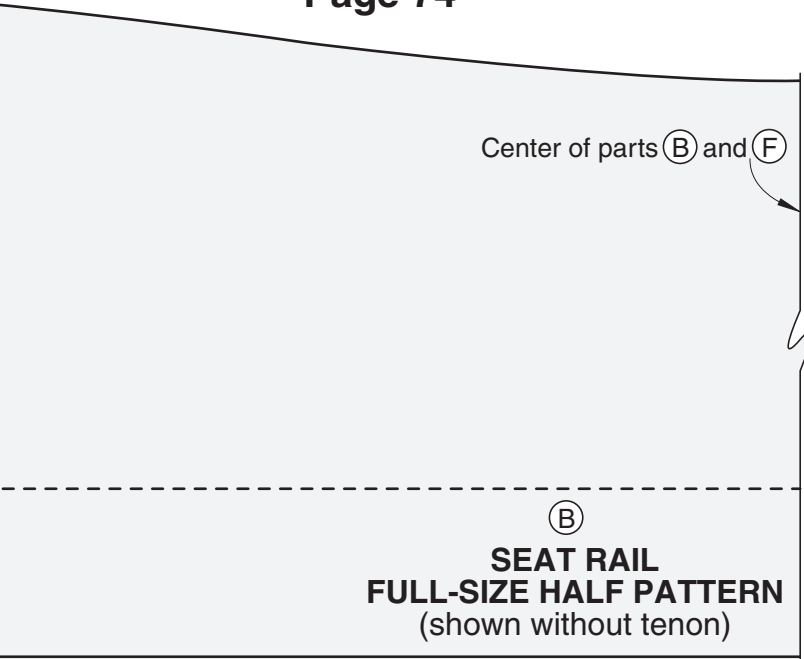

Mallet Page 96

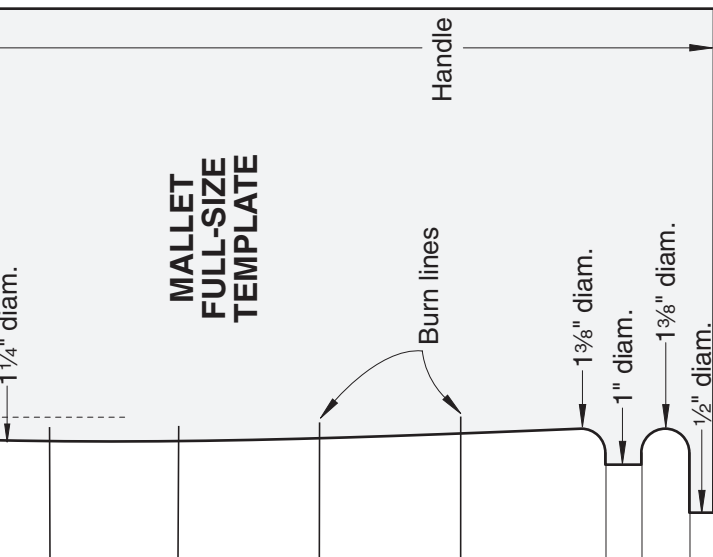

**FULL-SIZE
PATTERN
LETTER OPENER**

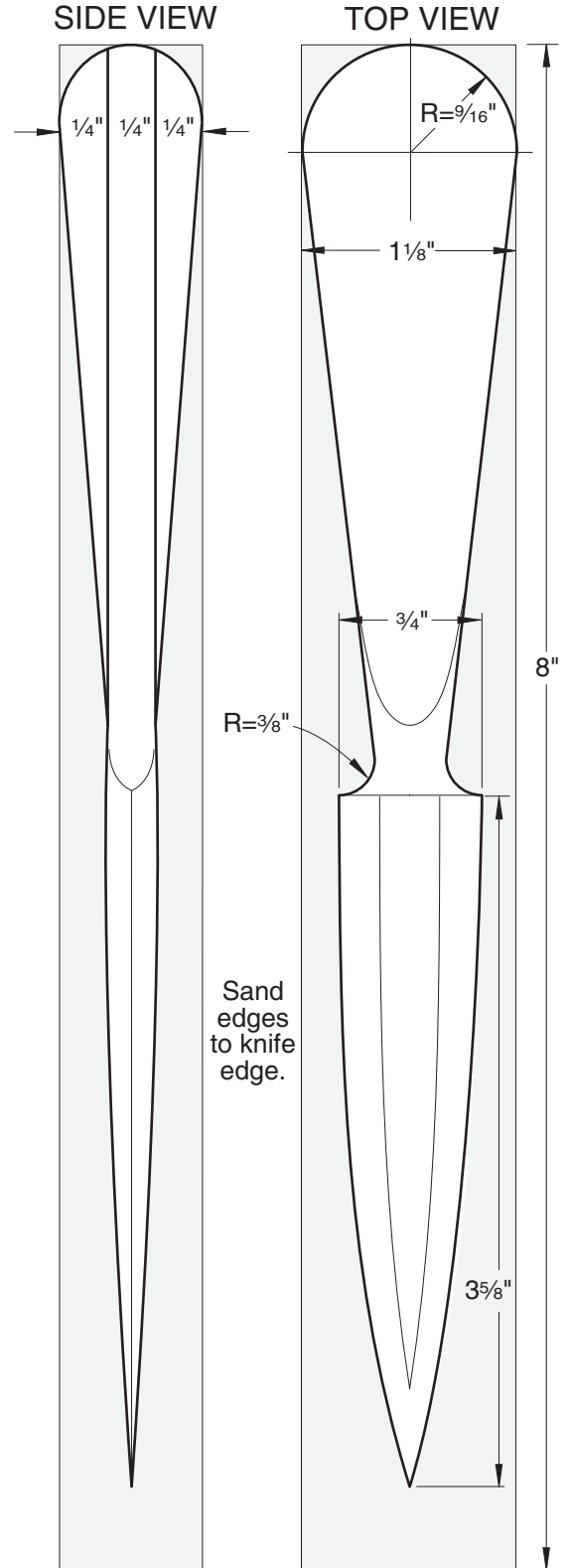

**Letter Opener
Page 65**

Best-Ever Plans for Your Yard or Home

View over **350** more plans at woodstore.woodmall.com

from the editors of **WOOD**® magazine



Adirondack Lawn Chair
WP-OFS-1001 \$13.95



Adirondack Footstool
and Side Table
WP-OFS-1014 \$10.95



Adirondack Rocker
WP-OFS-1016 \$13.95



Trellised Arbor
MD-00263 \$11.95



Mailbox Planter
MD-00195 \$8.95



Double Settee
WP-OFS-1075 \$13.95



Adirondack Chair
and footstool
MD-00197 \$11.95



Flower Tuteur
MD-00185 \$8.95



Planter Box
MD-00265 \$8.95



Arched Bench and Chair
WP-OFS-1040 \$13.95



Folding Adirondack Chair
WP-OFS-1062 \$13.95



Porch Glider
WP-OFS-1028 \$13.95



Porch Rocker
WP-OFS-1008 \$10.95



Picnic Table Suite
MD-00110 \$11.95



Porch Swing
WP-OFS-1002 \$10.95



Gardener's Potting Bench
MD-00193 \$8.95



Garden Arbor
MD-00050 \$8.95



Dog House
MD-00047 \$11.95



Arched Garden Bridge
MD-00139 \$11.95



Cold Frame
MD-00166 \$8.95

Call toll free **1-888-636-4478** for credit card orders.

Or visit the WOOD Store at woodstore.woodmall.com to order and see more woodworking plans, woodworking techniques, and tool reviews.

Complete guide to woodworking glues

Just as woodworking tools have changed, so have the glues that hold together your wood projects. If you still rely on just one glue, you've probably overlooked big performance advantages available from the latest generation of adhesives.

Do you know that there are now yellow glues with extended open times that have replaced

traditional white woodworking glues? Or have you heard about water-resistant and waterproof one-part glues for exterior projects?

To help you sort through the many glue choices, we've developed the poster that starts on the next page. Put it up on your shop wall and you'll never have to look far for an answer to your next gluing question.

Still stuck? There are now plenty of resources to help you navigate through glue issues, including the Titebond 800/347-GLUE help line and titebond.com Web site. Or, post your gluing question online at woodmagazine.com/generalforum. Woodworkers from far and wide likely will rush to your rescue.

4 common gluing mistakes to avoid

1 Gluing pieces not acclimated to the room temperature and moisture level. Glues won't set up properly if the boards are at different temperatures. And you'll notice a dimension change (stepped joints) if boards aren't at the same moisture level. So before machining and gluing, allow at least 3 days for all workpieces to adjust.

2 Overlooking the importance of glue shelf life. A manufacturing or expiration date should be printed on the glue container. Contact the manufacturer's customer service department if you can't decipher the code. For Titebond products (see example at *right*), the first number represents the final digit of the year in which the glue was produced; it's followed by a letter designating the month. ("A" represents January, "B" February, and so forth, skipping "I"). Ignore the rest of the code, which relates to the particular batch of glue. To know how old is too old, see the "Shelf Life" column on the poster.

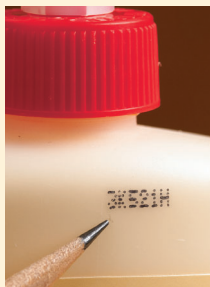

3 Poor procedures in removing glue squeeze-out. If you don't completely remove glue left on surfaces next to joint lines, your finish will have a splotchy appearance. To avoid problems, allow glue to skin over before removing excess. After glue loses its wet look, remove the squeeze-out with a sharp chisel or scraper. Then soak a clean rag in tap water, squeeze out the excess, and wipe down the joint. Follow with a dry rag.

4 Not waiting for the glue to cure before machining. Glue temporarily swells the wood along a glue line (**Drawing A**). If you joint, plane, or sand too quickly and remove the swelled wood, the joint will look good for only a short time (**Drawing B**). But when completely dry, your hastily machined joint will have a valley (**Drawing C**). To avoid problems, let the glue cure for the "Full-Strength Time" listed on the poster. (Effect exaggerated for clarity.)

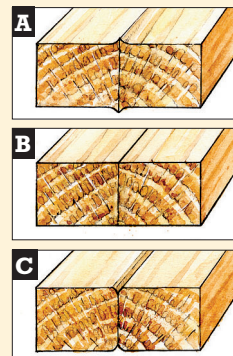

			TOTAL ASSEMBLY TIME (1)	MINIMUM CLAMP TIME (2)	FULL-STRENGTH TIME (3)	STRENGTH RATING (4)	WATER RESISTANCE (5)	HEAT RESISTANCE (6)
POLYVINYL ACETATE (PVA)	 ADHESIVE TYPE YELLOW	BEST USE Interior woodworking projects.	15 minutes	1/2 hour	24 hours	3,600 psi	G	G
	 YELLOW (extended assembly time)	Interior woodworking projects where long open time is desired. Recommended for bent laminations and larger, more involved assemblies.	20–25 minutes	1/2 hour	24 hours	3,510 psi	G	E
	 DARK WOOD	Ideal for dark hardwoods, such as walnut and mahogany. Interior use only.	15 minutes	1/2 hour	24 hours	3,600 psi	G	G
	 WEATHERPROOF	Exterior woodworking projects where water resistance is important. Interior projects that may come in contact with food and water.	15 minutes	1/2 hour	24 hours	3,750 psi	E	G
	 WEATHERPROOF (extended assembly time)	Exterior woodworking projects where long open time is desired. Good choice for gluing bent laminations. Interior projects subjected to water.	20–25 minutes	1/2 hour	24 hours	3,840 psi	E	G
	 MOLDING AND TRIM	Ideal for hard-to-clamp joints. Interior use only. Strong initial grip.	15 minutes	1/2 hour	24 hours	3,000 psi	G	P
	 WATERPROOF	Exterior projects requiring longer assembly time or lower application temperature than nonextended cross-linking PVAs.	20–25 minutes	1/2 hour	24 hours	4,000 psi	E	G
	 POLYURETHANE	Exterior projects requiring long working time and waterproof joinery.	20–25 minutes	2–4 hours	4 hours	3,500 psi	E	E
	 POLYURETHANE HOTMELT	Any project requiring quick-setting bonds. Needs little or no clamping. Bonds well when fit is marginal and with end grain. Bonds wide variety of materials.	30 seconds	1–2 minutes	24 hours	1,480 psi	E	E
	 HIDE GLUE	Ideal for authentic repairs in antiques and musical instruments that you may want to disassemble later. Will expand and contract with wood.	5 minutes*	10 minutes	24 hours	500 psi	P	P
	 HIDE GLUE-PREMIXED	Ready-to-use formula. Long assembly time. Sensitive to moisture (easy to disassemble later). Latex paint applied over dried glue will provide a crackled paint surface.	20–30 minutes	1 hour	24 hours	3,590 psi	P	E
	 5-MINUTE EPOXY	Excellent for repairs and joints that don't mate tightly. Cures quickly to any thickness. Fills gaps. Easily colored. Won't shrink. Bonds dissimilar materials.	3 minutes	1 hour	24 hours	5,000 psi	G	G
	 STRUCTURAL EPOXY	Like 5-minute epoxy but creates waterproof joint that can be used underwater. Easily colored. Won't shrink. Excellent for oily exotic woods.	1 hour	24 hours	7 days	7,500 psi	E+	E
	 CYANOACRYLATE (instant glue)	Strengthens weak areas and thin, delicate parts. Available in thin and thick (gap-filling) viscosities. Thin CA best used with tight-fitting parts.	**	*	24 hours	2,900 psi	E	P

1 How much time you have from applying glue to clamping the joint.

* Varies depending on water/glue ratio.

** No open assembly time for thin cyanoacrylates; gap-filling CA glues give you about 5 minutes of open time.

2 Depends on wood species, moisture content, temperature, and humidity.

* Thin, 15 sec.; gap-filling, 60 sec. For thin-CA joints, mate surfaces, and then apply CA glue.

3 Moisture delays water-based glues; dry conditions delay polyurethane glues.

4 Pressure in pounds per square inch (psi).

Depending on species, most wood will fail before the adhesive.

The high psi for epoxy, for example, reflects bonding strength for non-wood materials.

5 (E+) **Excellent plus** - Bond not affected by long-term submersion in water.

(E) **Excellent** - Bond not affected by short-term submersion or soaking in water.

(G) **Good** - Bond not affected by dampness or high humidity.

(F) **Fair** - Could be affected by severe humidity or damp conditions.

(P) **Poor** - Affected by almost any moisture.

woodworking glues



GAP-FILLING (7)	MINIMUM APPLICATION TEMPERATURE	CLEANUP		SHELF LIFE (YEARS)	NON-WOOD MATERIAL IT ALSO BONDS	COST (8)	COMMENTS
		BEFORE SET	AFTER SET				
No	50°F	Water	Scrape or sand	2	Leather, cloth, paper	\$.31/oz.	Fast grab. Best general-purpose interior glue. Least expensive. Good sandability. Long shelf life.
No	40°F	Water	Scrape or sand	1	Leather, cloth, paper	\$.37/oz.	Good sandability.
No	50°F	Water	Scrape or sand	2	Leather, cloth, paper	\$.33/oz.	Minimizes visibility of glue line in dark hardwoods. Dyed version of yellow glue.
No	55°F	Water	Scrape or sand	2	Leather, cloth, paper	\$.37/oz.	Approved for indirect food contact for such projects as cutting boards. Great general-purpose glue. Paintable. Dries and cures through chemical reaction. Long shelf life. Good for wet-use applications.
No	60°F	Water	Scrape or sand	2	Leather, cloth, paper	\$.41/oz.	Approved for indirect food contact for such projects as cutting boards. Paintable. Good for wet-use applications.
Yes	55°F	Water	Scrape or sand	1	Leather, cloth, paper	\$.34/oz.	Thick formula fills some thin gaps. Power sanding not recommended. Doesn't run or drip.
No	47°F	Water	Scrape or sand	1	Leather, cloth, paper	\$.53/oz.	Best option for most outdoor projects. Less messy than polyurethanes or epoxies.
No	50°F	Mineral spirits	Scrape or sand	1	Most materials except some plastics	\$1.08/oz. (12 oz. size)	Triggered by contact with moisture; may be applied to damp surface. Polyurethane adhesives foam up and are tough to remove from hands; wear gloves during application. Relatively long clamping time.
Yes	250°F	Not applicable	Scrape or sand	1	Most materials except some plastics	\$6-\$8 for a 50-gram cartridge	Requires specialty heat gun. WW30 (30-second) sets up quickly; WW60 (60-second) has gap-filling properties; WW75 (75-second) also bonds non-porous materials. Gloves recommended to protect from hot adhesive.
No	120°F	Water	Scrape or sand	Indefinite	Leather, cloth, paper	\$6-\$8 per pound	Dissolves in water. Use in glue pot/warming device (some use Crock-pot) at about 145°F. May be stored in refrigerator between uses. Disassemble joints with steam and heat. Water-based finishes could affect hide glue.
No	50°F	Water	Scrape, sand, or water	1	Leather, cloth, paper	\$.62/oz.	Requires no mixing, heating, or stirring. Has the "crackle" appearance of traditional hide glues.
Yes	35°F	Alcohol or lacquer thinner	Scrape or sand	1	Most materials except some plastics	\$1.00/oz.	Two-part adhesive. Resin and hardener react with each other, producing heat. Bonds many plastics. Gloves recommended. Three different hardeners available for various temperature ranges.
Yes	35°F	Alcohol or lacquer thinner	Scrape or sand	1	Most materials except some plastics	\$.70-\$.80 per oz.	Two-part adhesive. Resin and hardener react with each other, producing heat. For bonding oily woods (such as teak), sand, wipe with lacquer thinner, and apply epoxy within 60 minutes. Bonds many plastics. Gloves recommended.
*	Minus 65°F	Not applicable	Scrape, sand, or solvent	1	Most materials except some plastics	\$5.00/oz. for a 2-oz. bottle	Accelerator reduces cure time; 75 percent strength at end of cure. Specialty solvents debond joints. Little glue required; use one drop per square inch. Gloves recommended because it bonds to skin instantly.

6 Applies to power sanding and overheated conditions (for example, enclosed trailer on desert).

(E) **Excellent** - Glue loses little or no strength up to 150 degrees F. No gumming of the sanding belt, even with extensive sanding.

(G) **Good** - Noticeable loss of up to 50 percent of strength at 150 degrees F (substantially weaker joint at 150 degrees). Sands well, but can load up with extensive power sanding.

(P) **Poor** - Dramatic loss of 75 percent of strength at 150 degrees F. Poor sanding characteristics with any mechanical sanding (even hand-sanding).

7 Ability to bond successfully when materials aren't tightly mated.

* Thin, no; gap-filling, yes

8 Unless noted, retail cost per ounce in 16-ounce bottle.

The Best Wood Glue Ever

What makes Titebond® III Ultimate Wood Glue the best ever? It's waterproof, yet cleans up with water. It allows eight minutes of open assembly time and offers an application temperature as low as 47°F.

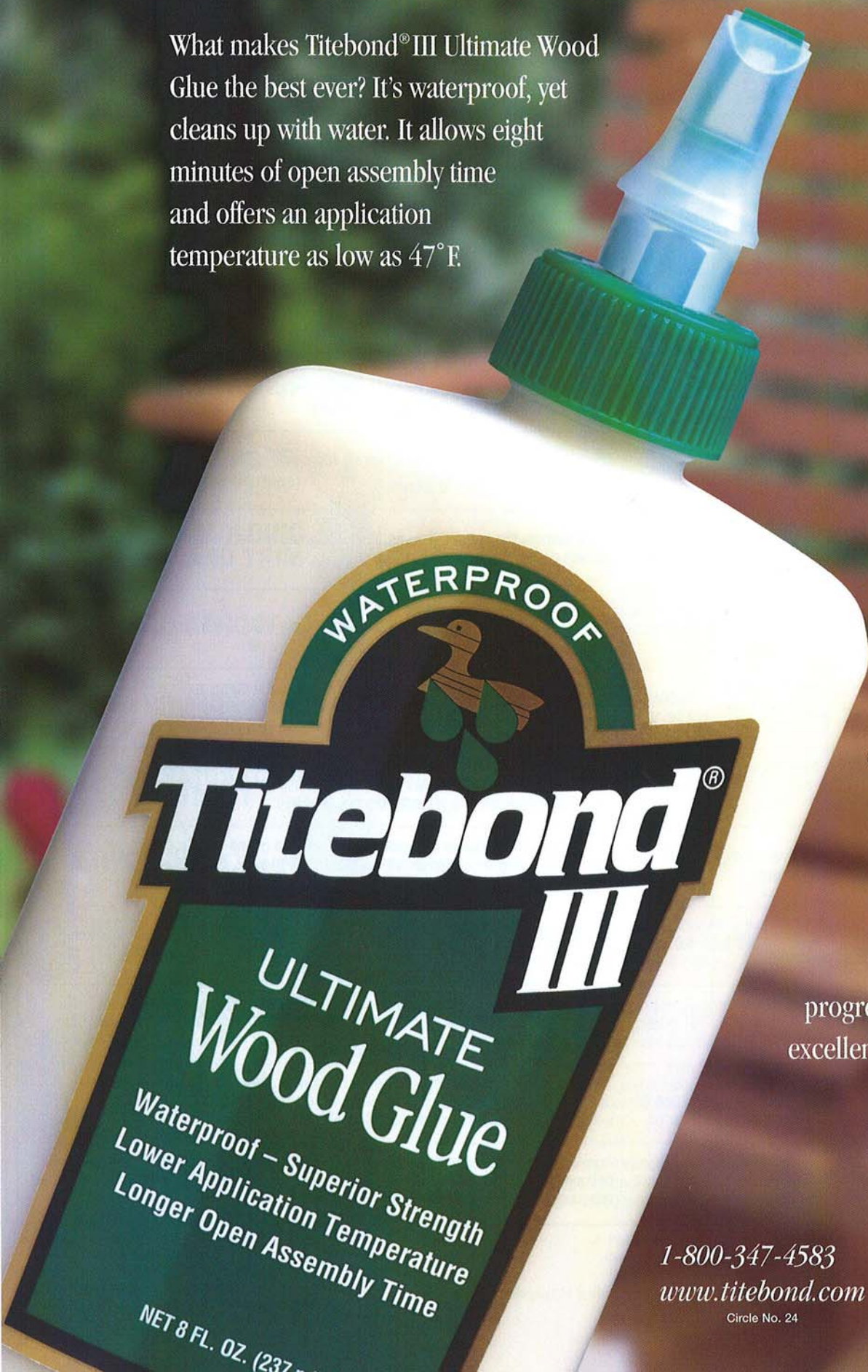

Plus it's vastly stronger, safer, easier to clean up and less expensive than polyurethane glues.

Titebond® III. We see it as a natural progression of tradition and excellence. You'll see it as the ultimate wood glue.

1-800-347-4583
www.titebond.com

Circle No. 24

Don't toss your scraps—turn them into something useful

Letter-perfect opener

It may not make bills more fun to open, but it will let you enjoy your woodworking firsthand.



1 Rip and crosscut one piece of a dark wood and two pieces of a light wood (we used wenge and lacewood respectively) to $\frac{1}{4} \times 1\frac{1}{8} \times 8$ ". With the dark wood in the middle, laminate the pieces face-to-face, with the edges and ends flush.

2 Make a copy of the Top and Side View patterns from the *WOOD PATTERNS*® insert. Using spray adhesive, adhere the paper Top View pattern to the top of the laminated blank.

3 Crosscut a piece of 2x4 to about 6" in length. Using cloth-backed double-faced tape, secure the blank to one face of the 2x4. Cutting just outside the marked line, bandsaw the opposite face of the blank to shape, as shown in **Photo A**. Using double-

faced tape, secure the waste back to the face from which it was just cut. Now, secure the 2x4 to that face, and cut the other face of the blank to shape. Tape the second piece of waste back in place. Remove the 2x4 from the blank.

4 Adhere the Side View pattern to one face of the laminated blank and bandsaw to shape, as shown in **Photo B**.

5 Remove the patterns and waste from the letter opener blank.

6 Power-sand or file the edges of the handle portion to shape, working slowly to get comfortable rounded edges. Hone the blade portion of the letter opener, as shown in **Photo C**. Strive for sharp edges and a point for ease in slitting envelopes later.

7 Finish-sand the letter opener and apply the finish. (We sprayed on three coats of aerosol gloss polyurethane.) Rub lightly with 220-grit sandpaper or 0000 steel wool between coats. 🌲

Project design: Will Cummer

Make the entire set

If you like the looks of this hardwood letter opener, you may want to spend a few more hours crafting the other four pieces of our matching desk set. See the May 2003 issue of *WOOD*® or download the plans online at woodmagazine.com/gifts

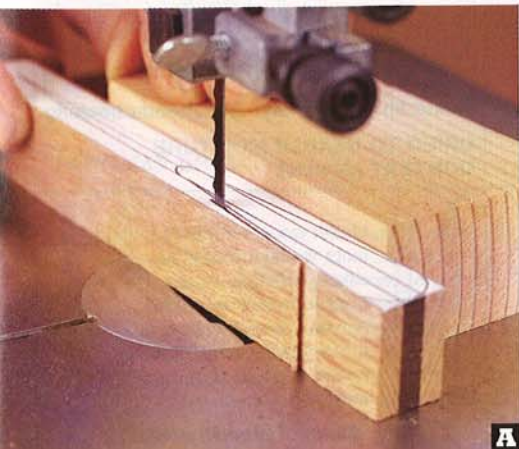

For safety when cutting, adhere the letter opener blank to a section of 2x4.

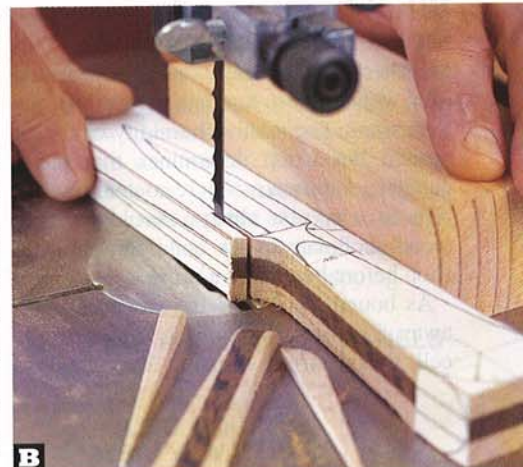

With the waste pieces taped back in place, reattach the 2x4 and finish bandsawing the blank to shape.



Adhere 100-grit sandpaper to a piece of plywood, and chamfer both blade edges.

Part II: how to deal with wood moisture

You probably know that wood has to be dried in order to be useful as lumber. Removing the water makes the material dimensionally stable, predictably machinable, and accepting of glues and finishes.

But have you stopped to consider how water is stored in wood? Do you know how that water is removed, or what happens to wood fibers as they dry?

Knowing the answers to those questions, and understanding what can go wrong if wood gets dried improperly, will make you a smarter buyer and user of this natural resource. Here's the short course on wood moisture and its effects.

What happens when wood releases water

Whether dried naturally (air dried), or in a kiln, wood dries to a certain percentage, and then stops. The relative humidity of the air around the wood determines this point, called equilibrium moisture content (EMC). This is why you always should let your wood acclimate to the conditions in your shop before beginning a project.

As bound water (see the wood cell cutaway for an explanation) is removed, the cell walls shrink, causing the wood to

Potential wood movement (inches) caused by an 8 percent change in moisture content:

	Quartersawn	Flatsawn
Cherry	.118	.227
Douglas Fir	.154	.253
Mahogany	.096	.131
Maple (hard)	.154	.317
Pine (white)	.131	.237
Red Oak	.128	.275
Walnut	.176	.250
Western Red Cedar	.077	.160
White Oak	.176	.336

change dimension. Boards shrink most across their tangential plane (face grain), so flatsawn boards shrink more than those that are quartersawn, as shown *above*.

Because wood cells vary in size, density, and orientation, they may shrink unevenly, causing boards to warp in various ways. To minimize these problems, shy away from boards that show wild figure, inconsistent growth-ring spacing, or an off-center pith.

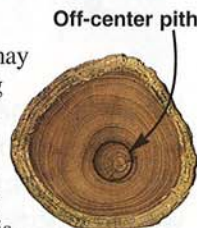

Shrinkage also stresses the wood. If not properly relieved, this tears the fibers apart, as illustrated *below*. You can stop shrinkage by replacing bound water with a stable substance that will remain in the cell walls. Turners do this by soaking blanks in polyethylene glycol (PEG). But this technique remains impractical for use with whole logs or large pieces.

CAREFUL DRYING RESULTS

Wood dries from the outside in, as the water it contains moves naturally from areas of highest to lowest concentration. This creates uneven pressures in the outer portion (the **shell**) and the inside of the board (the **core**).

WHEN DRYING GOES WELL

When dried correctly, a dry board appears the same as when wet, only smaller.

SCENARIO 1: FRESHLY CUT BOARD

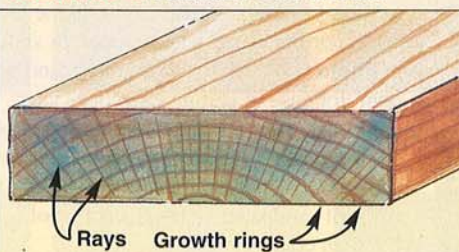

SATURATED ("GREEN") WOOD

Most trees arrive at commercial mills and get cut into logs while still fairly wet. That means each board that gets sliced free has a relatively consistent moisture content throughout its thickness and length. At this point, cell walls are fully saturated, and the cell cavities may still be filled completely with water.

SCENARIO 2: PROPERLY DRIED BOARD

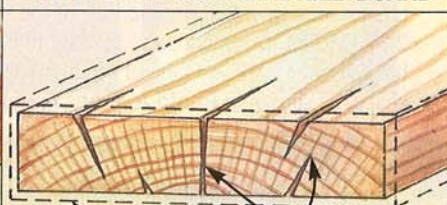

Board shrinks evenly. Minor end checking

DRIED TO USABLE MOISTURE CONTENT (6-11%)

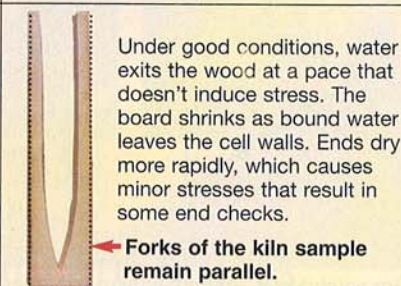

Forks of the kiln sample remain parallel.

WOOD CELL CUTAWAY VIEW

(Actual length = 1/16 - 1/4")



WATER VAPOR

— Small amounts may remain in the cell cavity, even in "dry" wood.

BOUND WATER

— This water is held in cell walls. Some remains behind in "dry" wood.

FREE WATER

— Water stored in the cell cavity. It is removed completely during the drying process.

As wood dries, it first sheds its **free water**, and then the **bound water**. Eventually, moisture loss stops, leaving some bound water and, possibly, **water vapor** in the cavity.

Calculating water content

Moisture content (MC) tells us the ratio of the weight of water in a piece of wood compared to its weight completely dry. We express it as a percentage. To determine MC, first weigh a piece of wood. Then, dry it until it contains no water (determined when weight loss stops). Next, compare the weights as follows:

$$\frac{\text{wet weight} - \text{dry weight}}{\text{dry weight}} = mc$$

For example, if a piece weighs 25 lbs. wet and 20 lbs. dry, its MC equals 25 percent:
 $(25-20)/20 = 5/20 = .25$ or 25%

Thankfully, you don't have to weigh and dry lumber to determine its MC. A moisture meter does the job for you.

For indoor projects, MC should lie between 6 percent and 11 percent to cope with dehumidified conditions. See the map, right. Construction lumber and outdoor woods, subjected to high humidity levels, should range from 15 to 20 percent MC to minimize expansion and contraction.

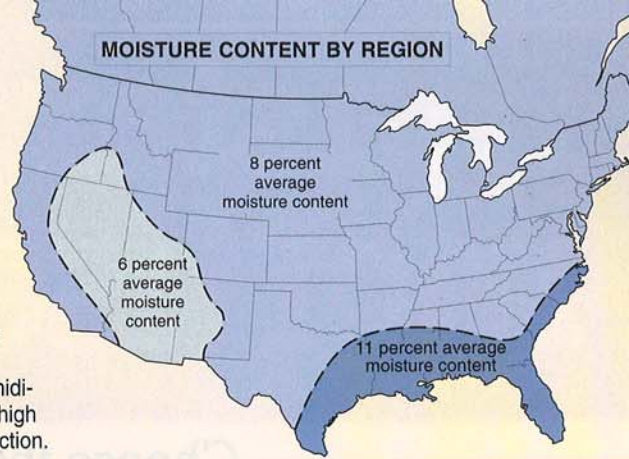

HOW WOOD WARPS IN A MILLED LOG

As boards dry, natural shrinkage causes them to cup away from the pith. The amount of cupping varies, depending on the board's location in the log.

Good boards may warp if they are dried improperly, as this piece did when dried too quickly.

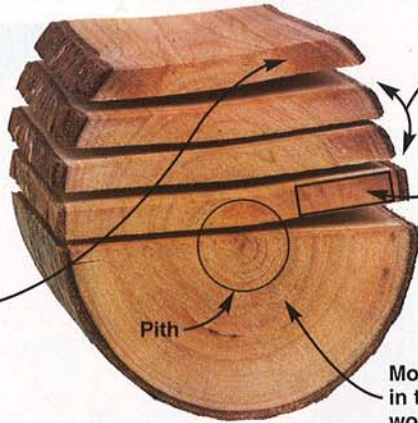

In general, boards located farthest from the pith cup the least.

Areas of quartersawn grain remain relatively flat.

Most severe cupping occurs in the pith and the juvenile wood that surrounds it.

Preventing problems with moisture and movement

Wood becomes most stable when it reaches EMC, and that's controlled by relative humidity. So what happens when humidity levels fluctuate? Wood is described as hygroscopic, meaning it will continue to take on and shed moisture and, because of this, expand and contract.

You can see how this happens in glued-up panels. At some points during the year, they may be dead flat. At other times, though, panels warp, as shown below. This movement won't cause problems if you build your projects to withstand it, as discussed in issue 150, page 80. Don't have that issue? You can download the article at woodmagazine.com/woodmovement.

To slow down the movement of water vapor into and out of the wood, always apply finish to your completed projects. Apply the same number of coats to all surfaces to equalize the rate of moisture exchange. This helps prevent cupping.

IN HIGH-QUALITY LUMBER

Lumber producers constantly manipulate the temperature, humidity, and airflow inside the kiln, and cut thin, tuning-fork-shaped cross sections regularly to look for signs of problems before they become too severe to correct.

WHAT CAN GO WRONG

Drying stresses wood fibers, which can lead to serious defects.

SCENARIO 3: REVERSE CASE HARDENING

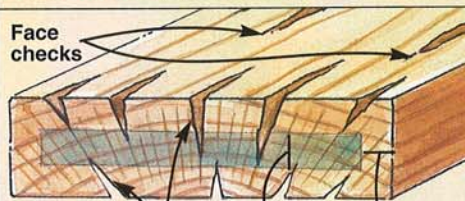

Severe end checks Wet Core Dry shell

PARTIALLY DRIED



In this situation, the board's shell dries too quickly in relation to the inner core. The shell tries to shrink but can't due to the still-swollen core. This tears the shell apart to create severe end and face checks. Reintroducing moisture can swell the checks shut, but the board is ruined.

Forks of the kiln sample spread open.

SCENARIO 4: CASE HARDENING

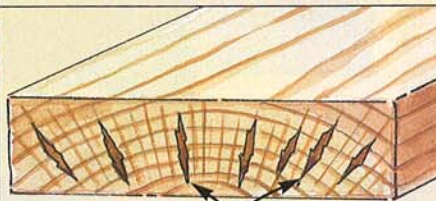

Honeycomb cracks

FULLY DRIED



Here, the shell dries too quickly, but retains enough strength that it doesn't tear apart. Instead, the shell holds together as it dries and crushes the still-swollen core. As the core dries and shrinks, it gets pulled apart by the shell.

Forks of the kiln sample close in.

WARPING IN GLUED-UP PANELS



Alternating growth rings



All growth rings oriented same way

(Cupping exaggerated for clarity)

Alternating growth-ring direction creates a panel that stays relatively flat, but wavy. Orienting all rings the same way produces a panel that cups but retains a smooth surface.

Up next: How wood's anatomy affects machining

In the next issue, we'll examine which wood properties determine success or failure when the time comes to machine your lumber into project parts. 🌲

Written by David Stone Illustrations: Eric Flynn

master the mortise-and-tenon

Choose the best method for your shop and budget, and we'll show you the foolproof path to success.

Make your mortise in one of three ways

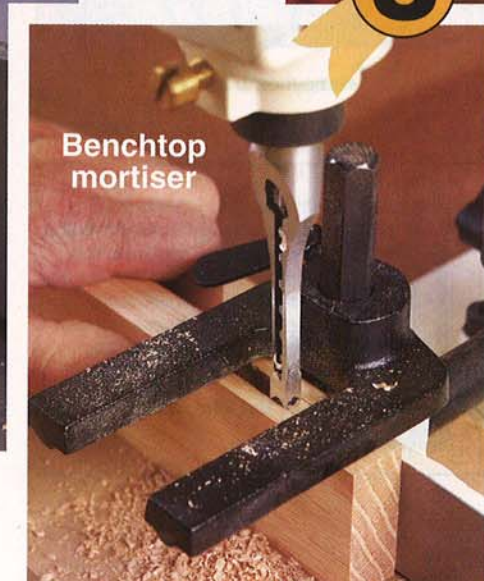
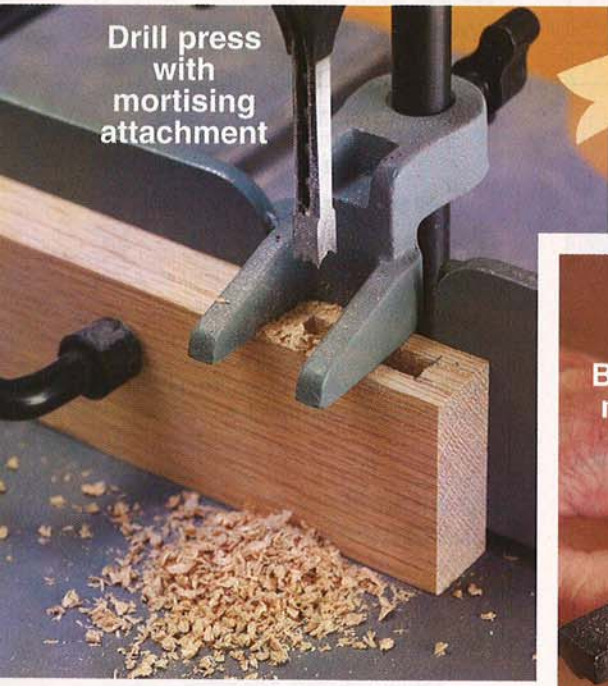
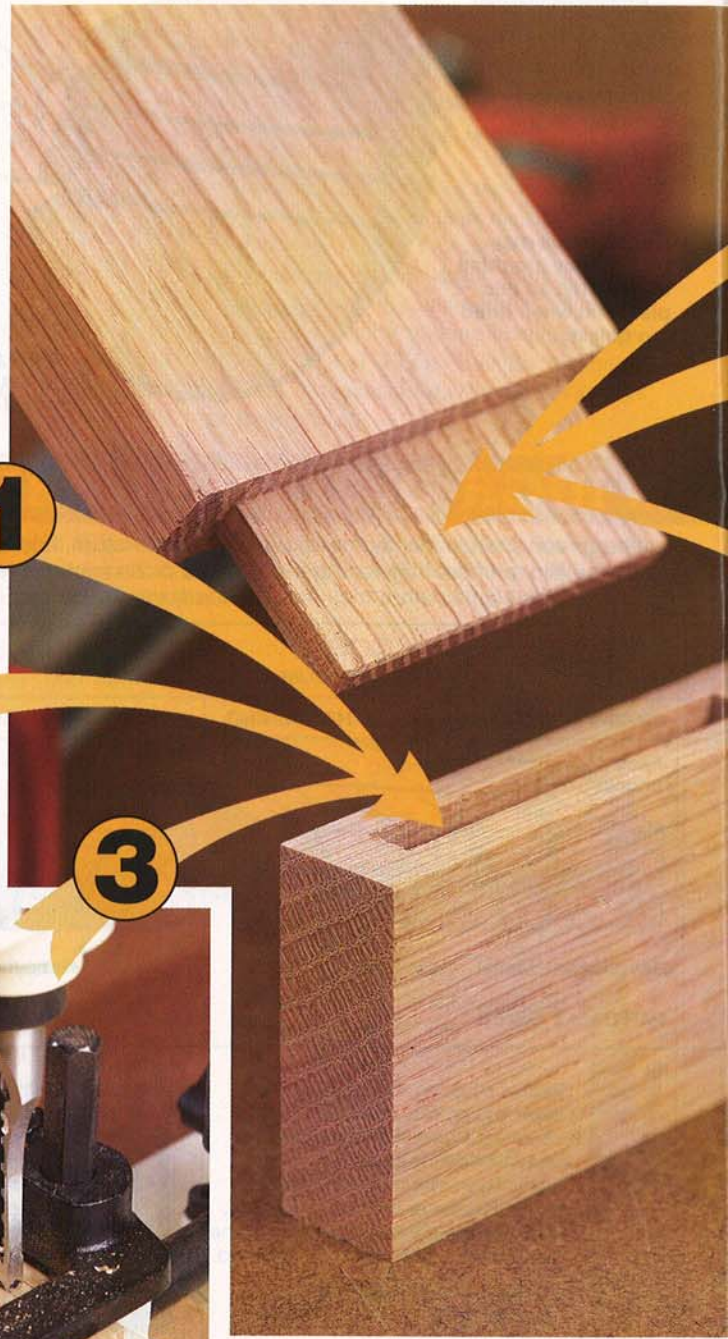
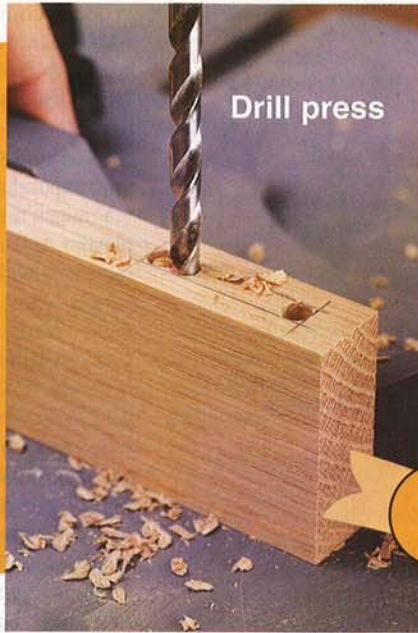

joint

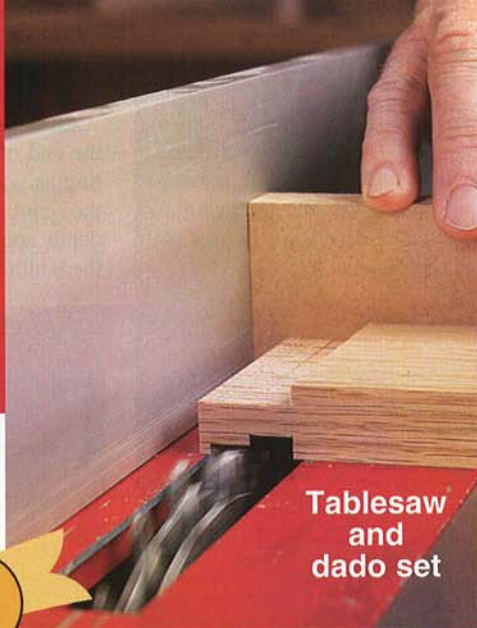

Tablesaw
and
dado set

1

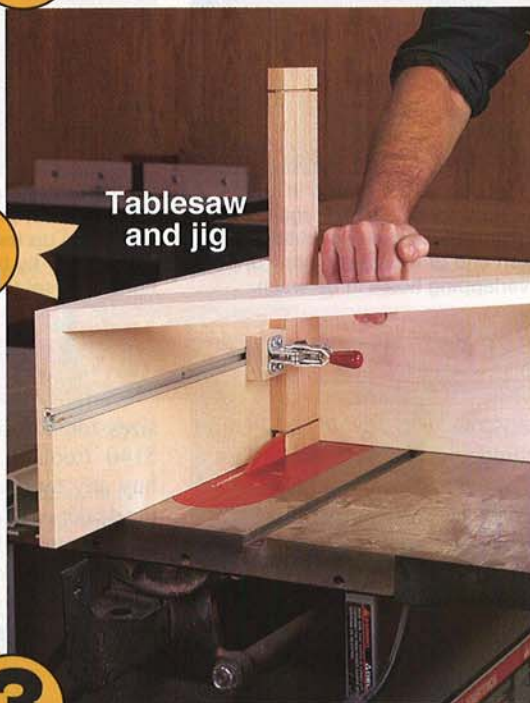

Tablesaw
and jig

2

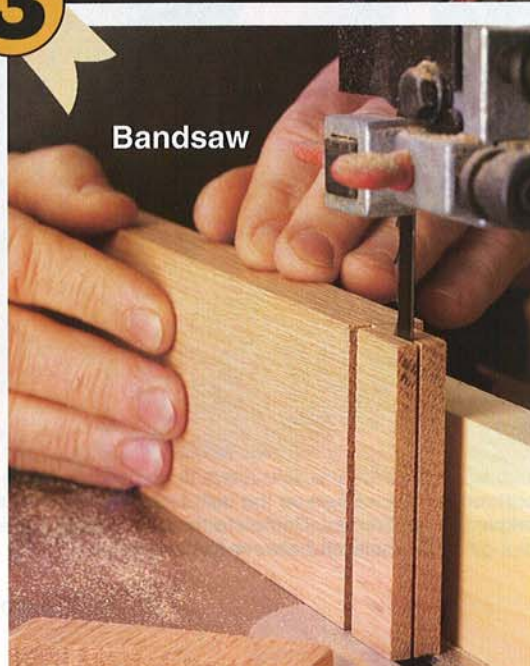

Bandsaw

3

Cut clean tenons using one of these techniques

Mastering mortise-and-tenon joinery has always ranked at the top of woodworkers' skill priority lists. That's because its great strength makes it the premier joinery technique for furnituremaking. No wonder our project designers used mortise-and-tenon joinery throughout the mission clock project on page 38.

Machining mortise-and-tenon joint members takes only a moderate amount of time and fuss, provided you have a few basic tools. To help you succeed at the king of joints, we'll walk you through making the blind mortise-and-tenon joint (the most common, where the tenon is completely enclosed in the mortise), letting you choose the options that best suit your tools and preferences. But before we begin, take a minute to review the basic terms and design proportions in the drawing, below.

Note: Plane your stock to consistent thickness prior to making these joints. (Include a couple of scrap pieces for testing tenoning setups.) This step makes all of your work easier while ensuring accuracy.

ANATOMY OF A BLIND MORTISE-AND-TENON JOINT

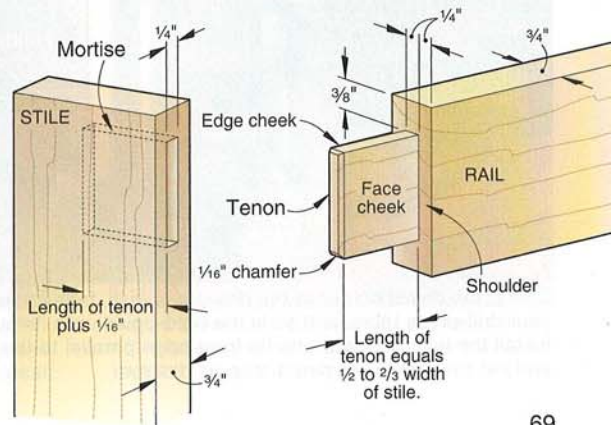

Start with the mortise

Always cut the mortise first and then size the tenon to fit snugly. It's quicker and easier to adjust the dimensions of a tenon (as we'll show later) than to change a mortise.

Establish the mortise width at one-third of the workpiece thickness. This ratio results in

a joint with plenty of strength in both the tenon and the sidewalls. Most woodworking projects call for 4/4 stock, which measures approximately $\frac{3}{4}$ " thick after surfacing and sanding, so a $\frac{1}{4}$ "-wide mortise works well for most of your projects.

Also, avoid mortising less than $\frac{3}{8}$ " from the end of a workpiece. This prevents splitting as you shape the mortise and assemble the joint. For strength, make the mortise depth approximately one-half to two-thirds the width of the workpiece.

Mortise method 1: Rely on your drill press

Pro: This method requires no expensive or specialized equipment.

Con: Cleaning up the mortise with a chisel takes time.

If you have a drill press and chisels, you're ready to mortise. Equip your drill press with a brad-point bit that matches the mortise width; a brad-point bit wanders less than a standard twist bit as you drill overlapping holes to form a mortise.

Now use a sharp pencil or marking knife and a combination square to lay out the mortise opening. Then set the drill-press fence to center the bit between the mortise sides and adjust the depth stop. (See page 52 for instructions on building a precision drill-press fence.) Finally, follow the two-step process shown in the photos at right.

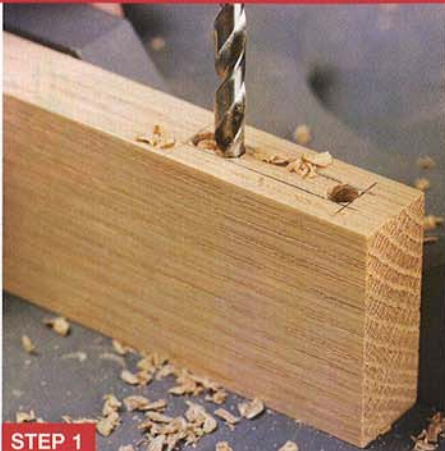

STEP 1

Adjust the fence to center your drill bit in the layout lines. Hold the workpiece against the fence, and form the mortise by drilling to full depth at each end of the layout. Now drill a series of overlapping holes in between.

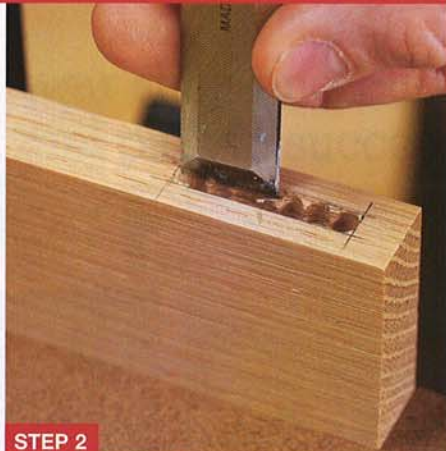

STEP 2

Clamp the workpiece to your workbench. Place a wide, sharp chisel on the layout line and clean up the mortise walls with hand pressure or by tapping with a mallet. Use a narrow chisel to square the ends.

Mortise method 2: Add a mortising attachment

Pro: A no-chisel way to drill and square the mortise in one step. Moderate price.

Con: Installing and removing the mortising attachment takes time, and the drill press can't be used for other tasks with the attachment in place.

To speed up your work, avoid hand chisel work by equipping your drill press with a mortising attachment. Its hollow-chisel design—a drill bit surrounded by a sharp, square sleeve—lets you form a mortise by drilling a series of square holes. We bought a kit that includes hollow chisels in four

sizes for \$70 from Tool Crib at 800/635-5140 (toolcrib.amazon.com). Before you buy any mortising attachment, check with the dealer or manufacturer to make sure that it fits your drill press. The photos below describe the simple procedure for using this handy accessory.

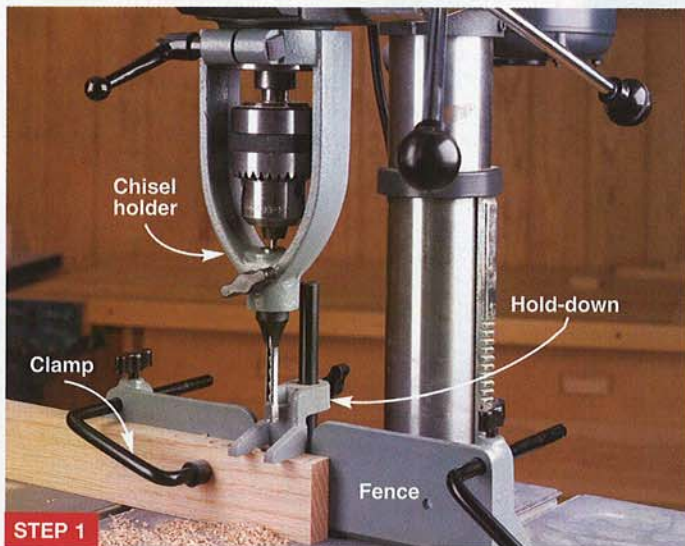

STEP 1

Clamp the chisel holder to the drill-press quill, fasten the fence to your drill-press table, and slide the hold-down onto its support rod. Install the hollow chisel with its front edge parallel to the workpiece and set the drill-press depth stop as desired.

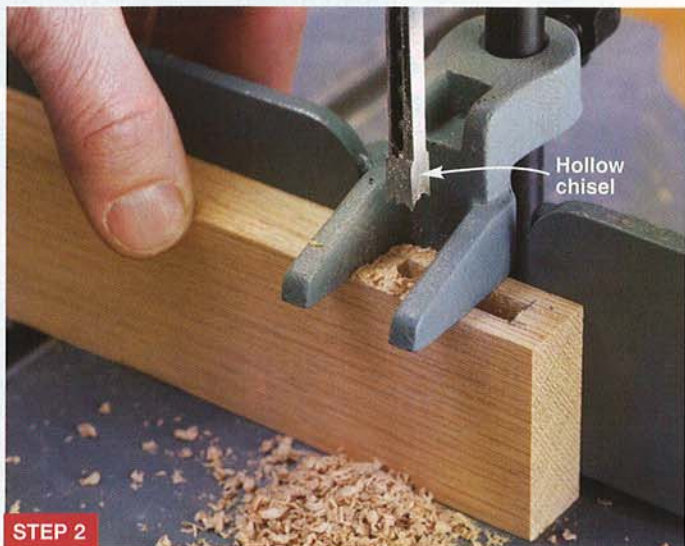

STEP 2

With the hold-down tightened against the workpiece, use moderate pressure on the quill-feed lever to bore a hole at each end of the mortise. Complete the job by drilling a series of slightly overlapping holes in between the end holes.

Mortise method **3**: Step up to a benchtop mortiser

Pro: Yields quick, clean mortises with minimal setup.

Con: A benchtop mortiser serves only one purpose in your shop. Entry-level models cost \$200–\$240.

Woodworkers who make a lot of mortises find it handy to own a dedicated machine. A benchtop mortiser works like the drill-press attachment, but it's always ready to use. Refer to the photos at *right* for details and see the tool review on *page 78* for information about the features and performance of several models.

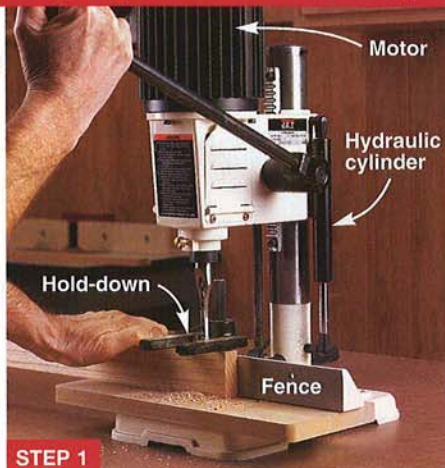

STEP 1

Set the fence of your benchtop mortiser to place the hollow chisel squarely within your mortise layout lines. Then adjust the hold-down to secure your workpiece.

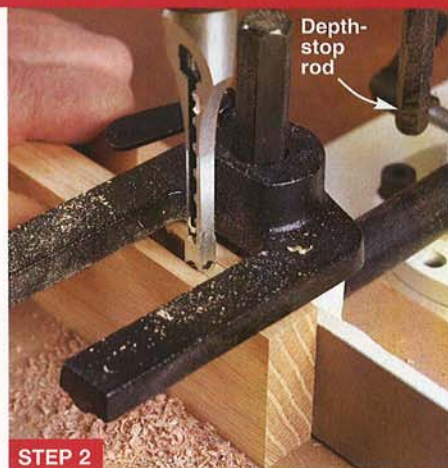

STEP 2

Adjust the depth-stop rod to establish the mortise depth and keep it consistent. Drill a hole at each end of the mortise and a series of slightly overlapping holes in between.

Now it's tenoning time

After you finish the mortises, use your scrap test pieces to set up for forming tenons. The ideal tenon slides into its mating mortise with firm hand pressure. Center the tenon on the edge of the workpiece (between

faces) and make it $\frac{1}{16}$ " shorter than the mortise depth; this hidden gap provides a place for excess glue and guarantees that the tenon won't bottom out in the mortise, spoiling the fit of the joint.

What's the best way to cut the tenons? Match your equipment to one of the operations discussed *below*. If you have it all—dado set, tablesaw, and bandsaw—experiment to discover which method you prefer.

Tenon method **1**: Keep it simple with your tablesaw and a dado set

Pro: No jigs are needed, and you make all cuts with the workpiece completely supported by the table.

Con: Some lesser-quality dado sets produce a rough surface and can splinter wood when crosscutting; such surfaces must be sanded. Also, you might find it awkward to handle workpieces over about 4' in length.

In the *WOOD*® magazine shop, we usually choose this method for cutting tenons because it's quick, simple, and reliable. Align your tablesaw rip fence parallel with the dado set and make sure that your miter-gauge fence sits at right angles to the dado set. These steps are critical for making a square, tight-fitting tenon.

You'll also need to install a miter-gauge auxiliary fence that extends to the rip fence. Make this fence by attaching a 2"-wide strip of straight material to the gauge with screws or double-faced tape. Now follow the step-by-step photos at *right*.

If you're in the market for a dado set, see issue 150, page 92, for the results of our tool test or visit woodmagazine.com/dadodl to purchase that article as a printable download. We reviewed 15 models, ranging in price from \$50 to \$260.



STEP 1

Install a dado set and set the rip fence. The distance from the fence to the left side of the dado set equals the tenon length.

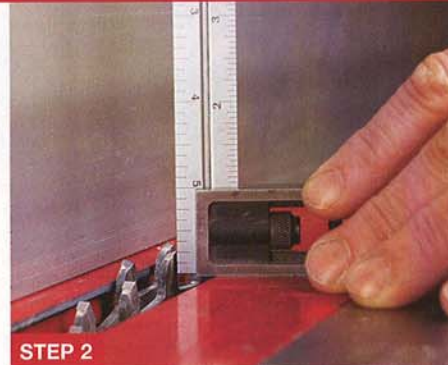

STEP 2

Adjust the dado set height to establish the thickness of the tenon. For stock surfaced to $\frac{3}{4}$ ", set this height at $\frac{1}{4}$ " and make test cuts.

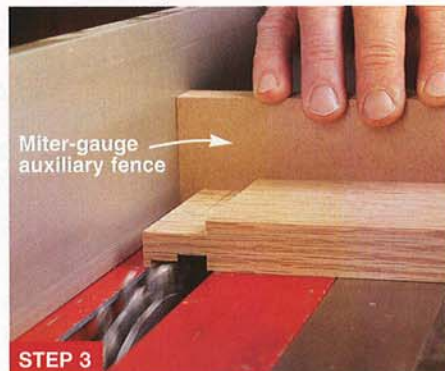

STEP 3

Butt the workpiece end against the rip fence for the first pass. Follow with more passes to form the cheek and then flip and repeat.

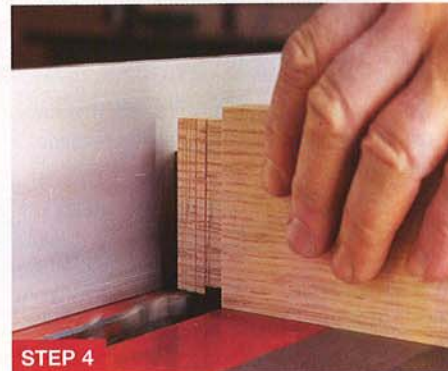

STEP 4

Adjust the dado set height if necessary and cut the tenon edge cheeks with the same methods used for the face cheeks.

Tenon method 2: Stay with the tablesaw, but add a shop-made jig

Pro: Smooth results at little cost.

Con: Saw blade's working height limits tenon length; jig takes up storage space in your workshop.

If you're not prepared to pay \$100 or more for a high-quality dado set, cut tenons with the workpiece held vertically on the tablesaw. You need a dependable jig for this operation; the drawing at right shows you how to build one at minimal expense. We designed it to clamp the workpiece in place and ride flush against the rip fence.

Now, mount a combination blade in your tablesaw and add an auxiliary fence to your miter gauge. Also install a zero-clearance throat plate to keep the thin waste pieces from being caught and kicked back. Now proceed as shown below.

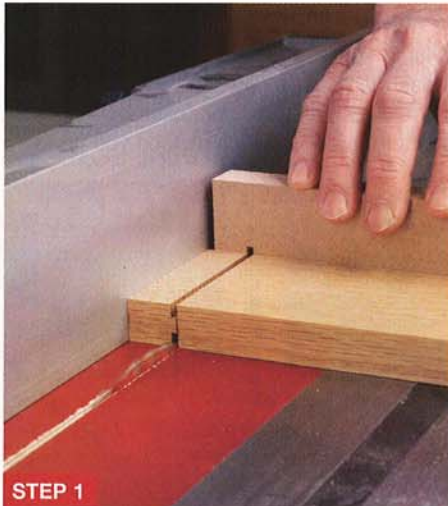
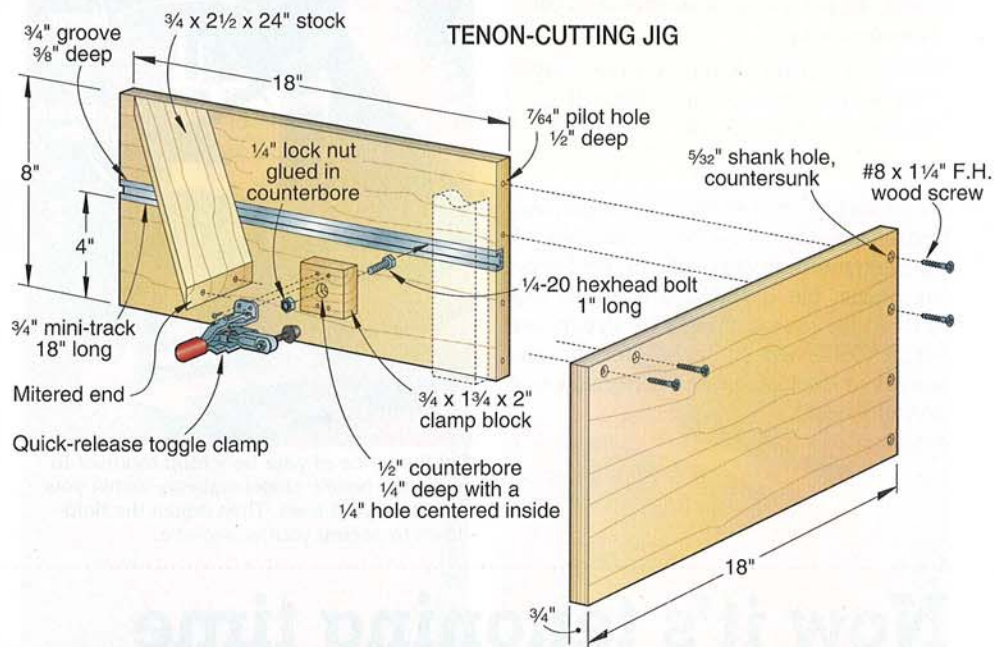

STEP 1

Set the rip fence to establish the length of the tenon and adjust the miter-gauge auxiliary fence so that it nearly touches the rip fence. Set the blade height to establish the tenon thickness. Butt the workpiece against the rip fence and make four passes around the workpiece. Cut a test piece as well.

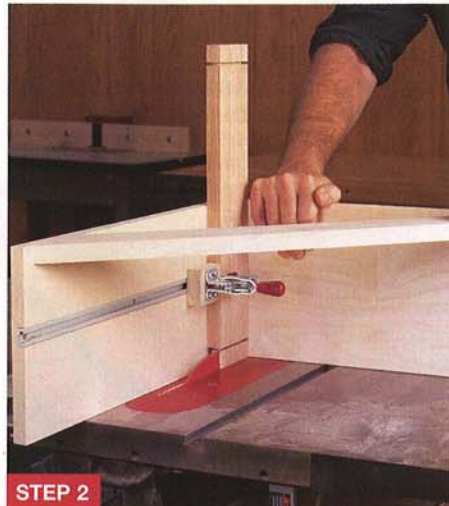

STEP 2

Before cutting the finished piece, use your test piece to set the rip fence. Raise the blade to the kerf's height and set the fence to cut the face cheek on the left side of the blade. Make the cut, flip the workpiece around, cut the other face cheek, and test the result in a completed mortise.

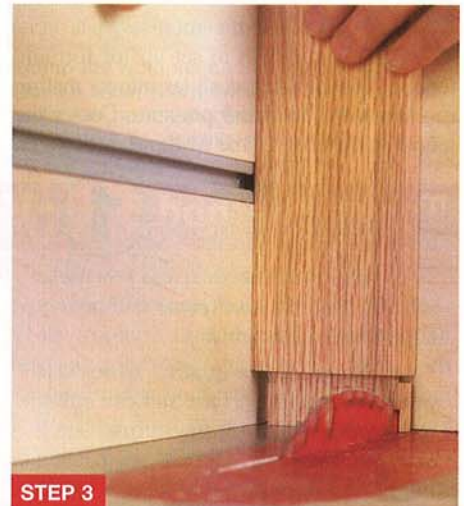

STEP 3

For the edge cheeks, remove the clamp and place a test piece as shown. Adjust the rip fence as necessary, hold the test piece firmly in place, and make the cut. Flip the piece edge for edge, cut the other edge cheek, and test the fit in a mortise. Adjust if needed and then cut the tenon edge cheeks.

Alternative tenon method 2: Buy a commercial jig

Pro: A fine-tuning knob makes this jig easier to adjust than our shop-made version shown above.

Con: Not designed to cut edge cheeks. Most jigs cost about \$100.

Would you rather buy a jig than make your own? In issue 152, we tested three similarly priced models and liked them all. A tenoning jig, such as the Delta version shown at right, offers great convenience and accuracy and should last a lifetime.

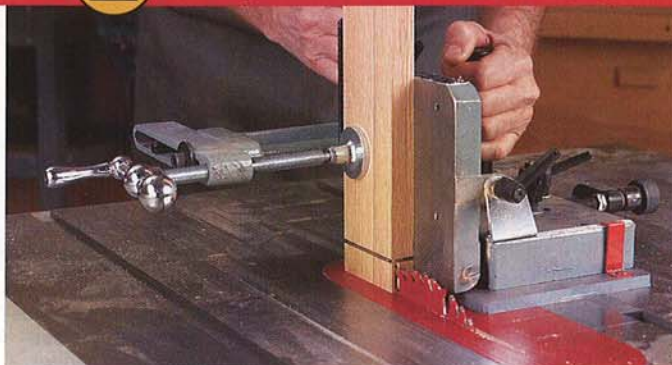

Cutting a tenon with a commercial jig is similar to the process used with our shop-made jig. Cut a kerf around the rail, use a zero-clearance throat plate, and cut on the side away from the jig body. Cut the edge cheeks with a bandsaw, as shown in Tenon Method 3, opposite page, top, or with a crosscut handsaw.

Tenon method **3**: Try the bandsaw for smooth cuts and versatility

Pro: It's easier to handle pieces over 4' long on a bandsaw than on a tablesaw.

Con: A dull or poorly tensioned blade results in an uneven face cheek.

None of the tenoning methods discussed so far solve the handling problem you face when cutting oversize workpieces. Rather than hold big pieces vertically on your tablesaw, cut their tenons on your bandsaw, supporting the weight of the rail with a table-height support.

Set up for this technique by installing a blade designed for resawing; a $\frac{1}{2}$ "-wide blade with three teeth per inch is a good choice. Make test cuts in scrap to determine whether you need to compensate for blade drift by setting your fence at an angle. A bandsaw works just fine for short workpieces, too, and surpasses many dado sets in producing smooth tenon cheeks.

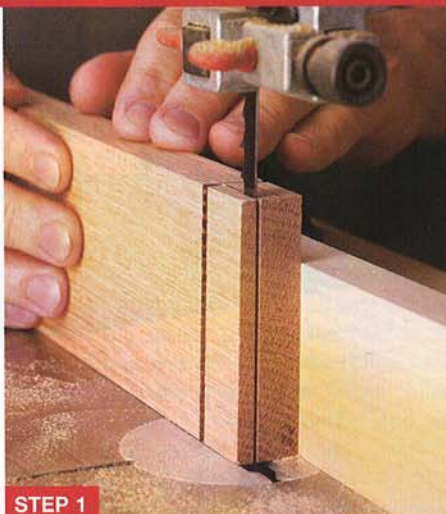

STEP 1

Cut a kerf around the workpiece as in Step 1, *opposite page*. Now, clamp a straight fence to the left side of your table to cut the face cheek on the right-hand side of the blade. Flip it edge for edge and cut again.

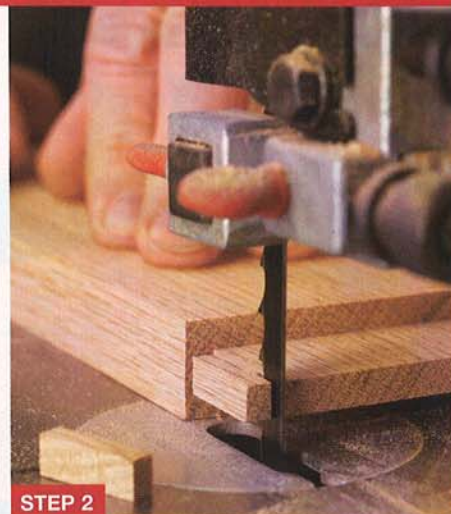

STEP 2

Unclamp and reset the bandsaw fence to cut the edge cheeks, as shown. Again, set up the operation so the waste piece falls away from the blade instead of being trapped against the fence.

Fine-tune tenons for a good fit

Despite your most careful efforts, sometimes you'll need to make a tenon thinner or thicker to achieve a good fit. Don't count on glue alone to fill gaps—that approach will only weaken the joint.

For a tenon that's slightly oversize, use a sanding block to remove a modest amount of material as shown in the "Sanding" photo. Sandpaper wrapped around a block is likely to ruin the straight line of the shoulder, so use self-adhesive sandpaper on the bottom only. Or, if you prefer, use a rabbeting plane and a light touch, as shown in the "Planing" photo.

Fix a tenon that's too thin by gluing on oversize filler pieces as shown in the "Shimming" photo. Saw, plane, or sand the tenon to final thickness after the glue dries.

Finally, use a sanding block to form a chamfer around the end of each completed tenon, as shown in the "Chamfering" photo. This simple step helps you get the tenon started into its mortise with no fuss at assembly time even if the glue has begun to swell the wood fibers. ♣

Written by Jim Pollock with Kevin Boyle



SANDING

Use 150-grit sandpaper and a sanding block to slightly reduce the thickness of a tenon. Place self-adhesive paper on a block or stick regular sandpaper in place with spray adhesive or double-faced tape.

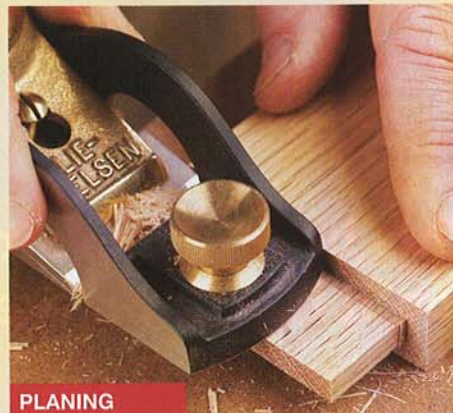

PLANING

A sharp rabbeting plane removes material more quickly than sandpaper. Here you see a low-angle plane (Lie-Nielsen model 60 $\frac{1}{2}$ R), designed to cut efficiently across grain and leave a smooth surface.

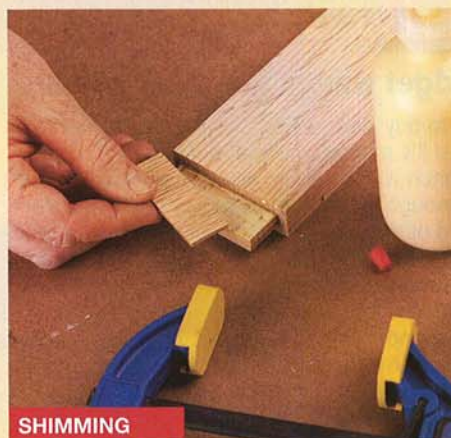

SHIMMING

When a tenon proves to be too thin, glue a wood shim on each face cheek to keep the tenon centered. Make the shims thick enough to allow remilling of the tenon.

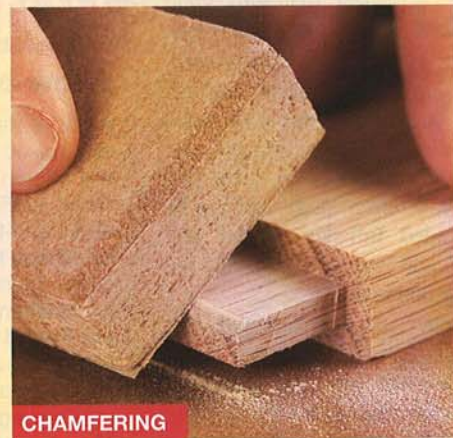

CHAMFERING

Grab your sanding block again to shape a $\frac{1}{16}$ " chamfer around the tenon end. A chamfered tenon slides more easily into place as you put the joint together.

easy-does-it garden bench



This beauty's so simple to build, you'll be sitting pretty in no time.

Looking for a weekend project that will yield years of outdoor service? Here it is. This contoured, eye-catching bench derives its durability from rock-solid mortise-and-tenon joinery and decay-resistant cedar. It has just eight different parts, and we've included full-size curved seat rail and support patterns for your convenience.

Better yet, you can build the bench from knotty-grade cedar posts and deck boards, yet achieve the knot-free appearance of clear-grade cedar at a fraction of the cost. To learn how, see the **Builder's Note** from our penny-pinching Design Editor, Jeff Mertz, at *right*.

BUILDER'S NOTE

A low-budget way to get clear cedar

If you've tried to buy clear-grade cedar recently, you've discovered that it's a pricey, special-order item. To build this garden bench with premium stock, you would spend about \$245, enough for most of us to say uncle. But, for about one-third of this cost, you can get the same unblemished look that I did using readily available knotty-grade cedar (found at home centers) and working around the knots when laying out the parts, as shown *right*. Of course, you'll need to spend a little time finding the clearest boards (it took me about 15 minutes), and you may need to buy an extra board or two for insurance, as I did. But the savings are significant. My materials cost about \$85, including the extra boards.

Jeff Mertz
Design Editor

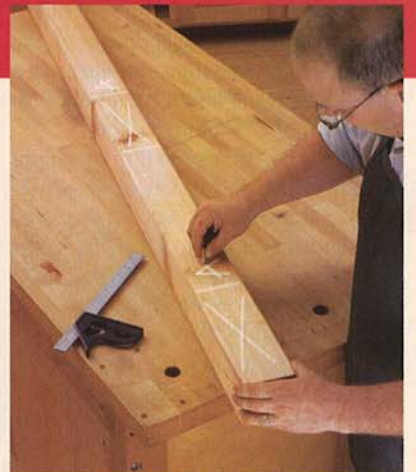

Look over your stock to find the clearest areas. Then, lay out the parts with chalk, as I'm doing here on a 4x4 post for the bench legs (A).

For the lumber and other items needed to build this project, see [page 77](#).

Start with the legs

1 From a 4x4 cedar post 8' long, cut four clear 18"-long workpieces for the legs (A). Using your jointer, square two adjacent faces on each piece. Then, cut a 2¼"-square leg from each piece.

2 Mark the two best faces on each leg for the outside. Then, lay out the ¾x2½" mortises on the legs' inside faces, where dimensioned on **Drawing 1**, making sure you have mirrored pairs of legs. Using a ⅜" Forstner bit in your drill press and a fence to keep the holes aligned, drill the ⅞"-deep mortises. (The mortises are ⅛" deeper than the mating tenons' length to prevent glue squeeze-out and ensure tight-fitting joints.) Now, square their sides and ends with a chisel.

3 Rout ⅛" round-overs along all of the legs' edges and ends. Then, sand the legs smooth using 180-grit sandpaper.

Next up: the frame parts

1 From 5/4 cedar deck boards planed to 1" thick, cut the seat rails (B), bottom side rails (C), and front/back rails (D) to the sizes listed in the **Materials List**. Cut an extra piece with the same

thickness and width for forming test tenons. (Our deck boards measured 1⅛" thick. We planed them to 1" thick by removing equal amounts of material from both faces.)

2 To form the tenons on the rails' ends, where dimensioned on **Drawing 2a**, fit your tablesaw with a ¾" dado blade, and raise the blade to ⅝". Next, attach an auxiliary fence to the saw's rip fence and an auxiliary extension to the miter gauge as a backer to prevent tear-out. Position the fence so it just touches the dado blade. Now, form a ⅜" tenon ¾" long on the end of your test piece, as shown in **Photo A**. Test the tenon's fit in the leg (A) mortises. If necessary, adjust your setup, and retest. When you're satisfied with the fit, cut the tenons on the ends of the rails (B, C, D).

3 Raise your dado blade to ½". Then, crosscut both edges on your test piece to trim the tenon's width to 2½". Check its fit in the leg mortises. Adjust the blade height, if necessary, to achieve a good fit. Now, trim the tenons on the rails.

4 Make four copies of the combined seat rail (B) and seat support (F) full-size half

patterns on the **WOOD Patterns®** insert. Set two of the copies aside for a seat support. Then, cut out and spray-adhere the remaining copies to a seat rail, aligning the applicable patterns' ends with the tenons' shoulders. (You'll need to flip one of the patterns over to complete the contour.) Now, bandsaw and sand to the pattern line. Using the rail as a template, mark the contour on the other seat rail, and cut and sand it to shape. Remove the patterns.

5 Lower your dado blade to ¼". Then, making two passes, cut a 1" dado centered on the inside face of the bottom

1 LEG
(Left rear shown)

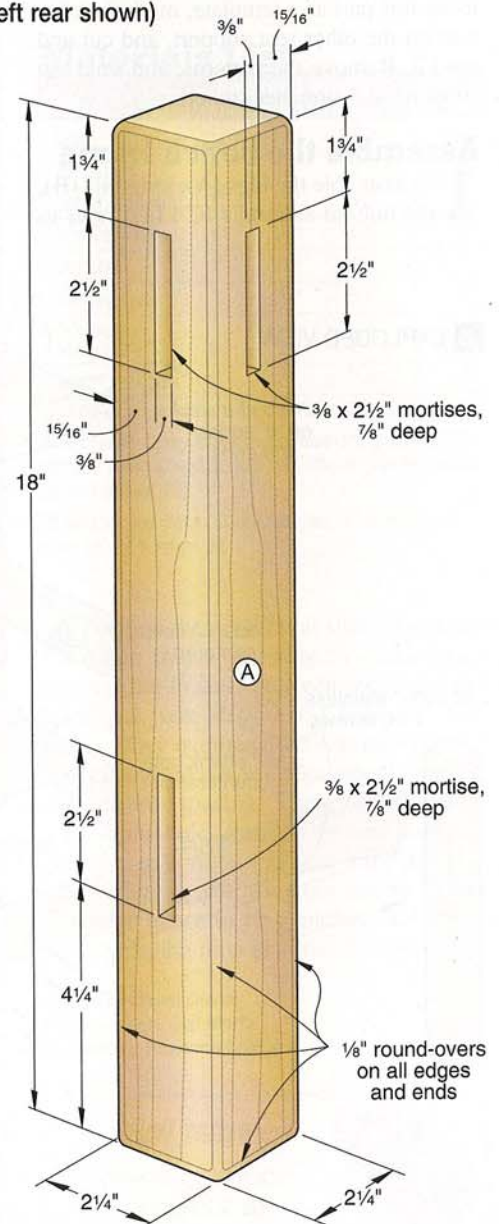

CUT A TEST TENON

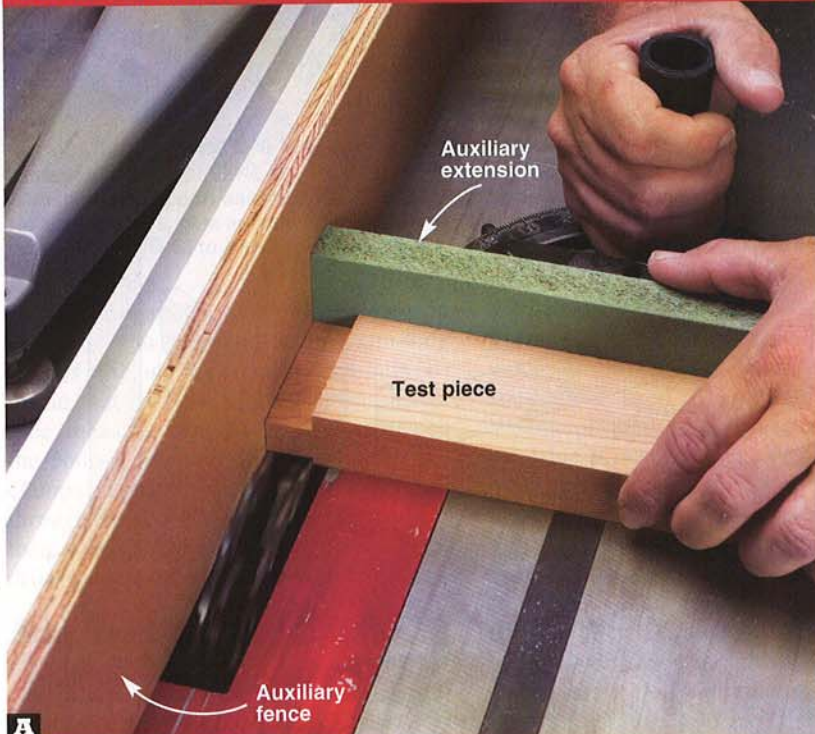

Keeping the end of your test piece tight against the auxiliary fence, crosscut both faces to form a ⅜" tenon ¾" long.

side rails (C), where shown on **Drawing 2**. Now, cut two 1" dados $\frac{1}{4}$ " deep on the inside face of the front/back rails (D), where dimensioned.

6 Mark the center of the arches on the bottom side rails (C) and front/back rails (D), where dimensioned. Then, bend a fairing stick to these points, and draw the arches. (For a free fairing stick plan, go to woodmagazine.com/fairing.) Bandsaw and sand the arches to shape.

7 Round over the edges of the rails (B, C, D), where shown. Sand the parts smooth.

8 Cut the stretcher (E) and seat supports (F) to the sizes listed. Then, retrieve the two copies of the seat support half pattern, and spray-adhere them to a seat support, aligning them with the support's ends. Bandsaw and sand them to shape. Now, using this part as a template, mark the contour on the other seat support, and cut and sand it. Remove the patterns, and sand the supports and stretcher smooth.

Assemble the bench frame

1 To assemble the legs (A), seat rails (B), and bottom side rails (C), first refer to

Drawing 2 for the required orientation of the parts. Then, referring to the manufacturer's instructions, apply a thin layer of polyurethane glue in the mortises of two legs, and assemble the legs, a seat rail, and a bottom side rail. Clamp the assembly together, as shown in **Photo B**. (We applied glue only in the mortises to prevent squeeze-out.) Repeat to assemble the other two legs, seat rail, and bottom side rail.

2 Glue and clamp the seat supports (F) between the front/back rails (D), and check for square. Then, drill countersunk screw holes through the rails, centered in their dados, and into the supports, where shown. Drive the screws. (We bought the stainless steel flathead screws for our project from McFeely's. Call 800/443-7937 or go to www.McFeelys.com.) Keep the assembly on a flat surface while the glue dries.

3 Glue and loosely clamp the end assemblies (A/B/C) to the seat

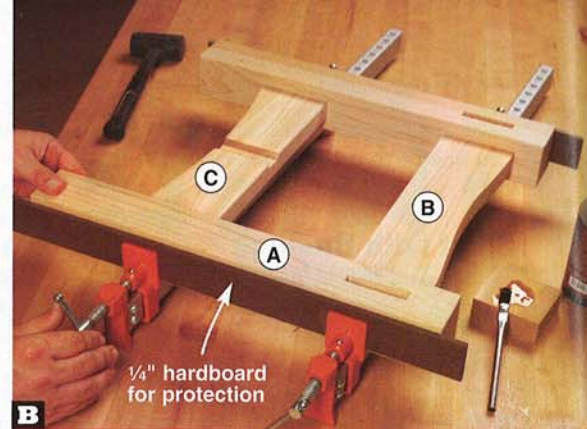

ASSEMBLE THE ENDS

Using scrap $\frac{1}{4}$ " hardboard strips to protect the legs (A) from marks, clamp together the legs, seat rail (B), and bottom side rail (C).

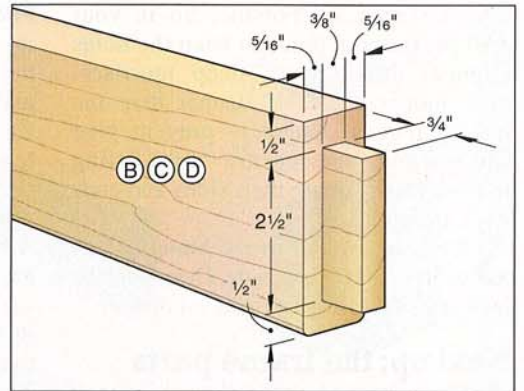

2 EXPLODED VIEW

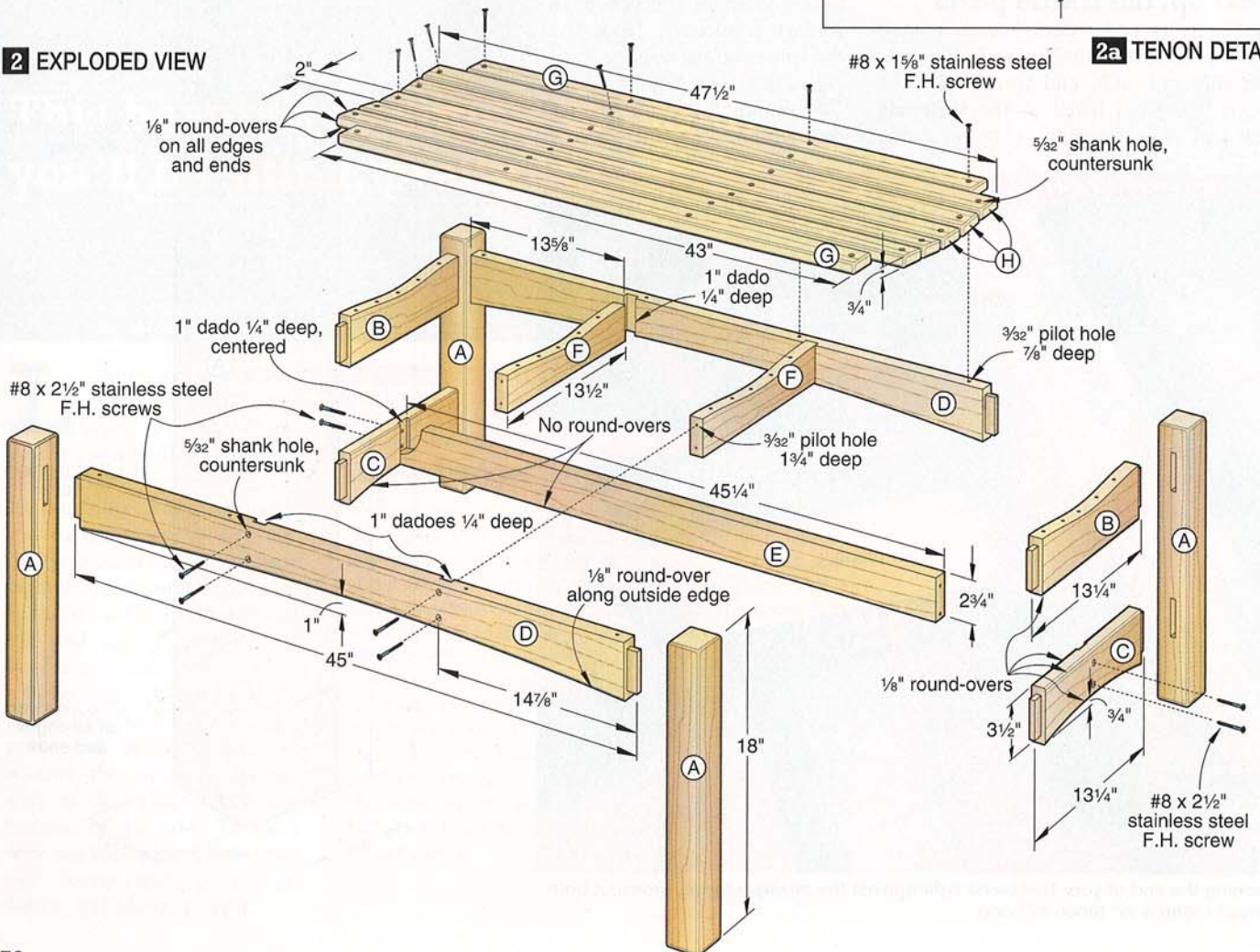

Cutting Diagram

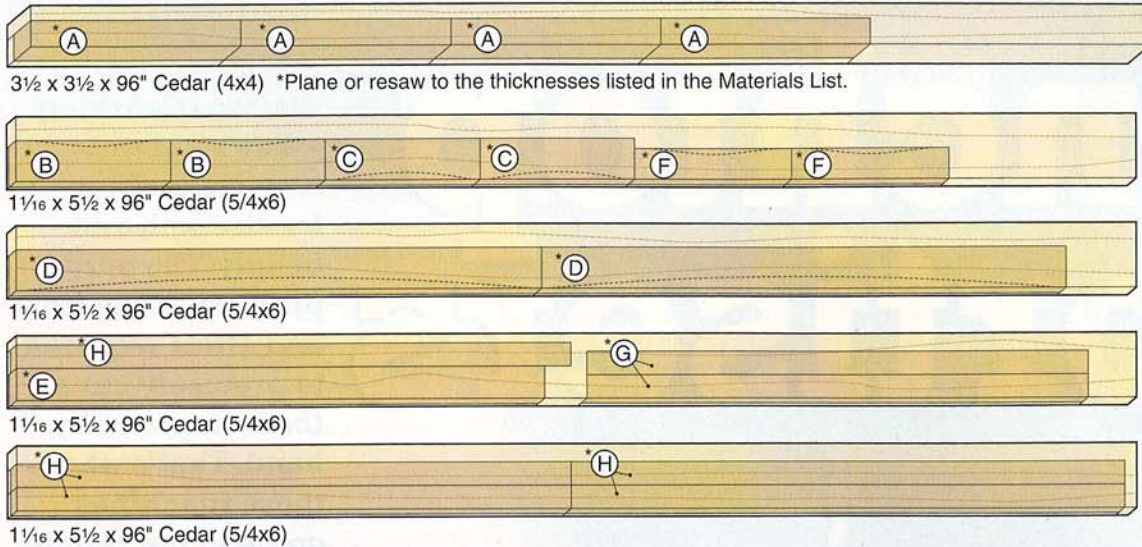

COMPLETE THE FRAME



With the seat support assembly (D/F) on 1 1/2"-tall spacers, glue and clamp the end assemblies (A/B/C) to the front/back rails (D).

support assembly (D/F), as shown in **Photo C**. You can avoid using extra-long clamps by clamping from the seat rails (B) to the seat supports (F), as shown. Then, glue the stretcher (E) in place between the bottom side rails (C), and tighten the clamps. Drill countersunk screw holes through the bottom side rails, centered over their dadoes, and into the stretcher. Now, drive the screws.

Add the slats and finish

1 Plane 5/4 cedar deck boards to 3/4" thick. Cut the front/back seat slats (G) and center seat slats (H) to size. Round over the slats' edges and ends, where shown on **Drawing 2**. Sand the slats smooth.

MOUNT THE SEAT SLATS

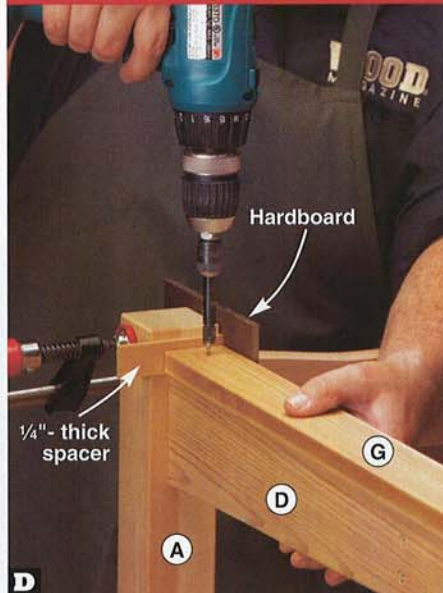

Using 1/4"-thick spacers and hardboard scraps to position the front/back seat slats (G) on the frame, drill the holes, and drive the screws.

2 Before mounting the slats, apply a coat of waterproof penetrating oil wood sealer to the bench frame and slats. (We used Behr Premium Clear Weatherproofing Wood Sealer & Finish, available at Home Depot.) To give the bottoms of the legs (A) extra protection, soak them in sealer in a disposable pie pan.

3 When the sealer dries, position the front/back seat slats (G) on the bench frame with their ends 1/4" from the legs (A) and their inside edge flush with the legs' inside face, as shown in **Photo D**. Then, drill countersunk screw holes through the slats and into the front/back rails (D), where shown on **Drawing 2**, and drive the screws.

Materials List

Part	FINISHED SIZE			Matl.	Qty.
	T	W	L		
A legs	2 1/4"	2 1/4"	18"	C	4
B seat rails	1"	3 1/2"	13 1/4"	C	2
C bottom side rails	1"	3 1/2"	13 1/4"	C	2
D front/back rails	1"	3 1/2"	45"	C	2
E stretcher	1"	2 3/4"	45 1/4"	C	1
F seat supports	1"	2 5/8"	13 1/2"	C	2
G front/back seat slats	3/4"	2"	43"	C	2
H center seat slats	3/4"	2"	47 1/2"	C	5

Materials key: C—choice of cedar, redwood, or cypress.

Supplies: Spray adhesive, polyurethane glue, #8x2 1/2" stainless steel flathead screws (12), #8x1 5/8" stainless steel flathead screws (28).

Blades and bits: Dado-blade set, 1/8" round-over router bit, 3/8" Forstner bit.

4 Position the center seat slats (H) on the bench frame, inserting 1/4"-thick spacers (not hardboard) between them and the front/back seat slats (G). Center the seat slats so they overhang the seat rails (B) 3/8" at each end. Make any adjustments needed for uniform spacing. Then, drill countersunk screw holes through the seat slats and into the seat rails and seat supports (F), where shown, and drive the screws. Now, move the bench to your garden, kick back, and take some time to smell the roses. 🌹

Written by **Owen Duvall**
Project design: **Jeff Mertz**
Illustrations: **Roxanne LeMoine**

Find more
great outdoor
projects at
woodmagazine.com/outdoor



SHOP-TESTED

benchtop mortisers

Few woodworking joints rival a mortise-and-tenon for strength and beauty. The only problem is the time and effort required to precisely cut *all those mortises* by hand. That's where these machines come to the rescue. Read on to learn which of seven machines bore best.



Are you ready for a benchtop mortiser?

The article on *page 68* shows three options for making mortises, and your need for speed may motivate you to buy a dedicated machine. Benchtop mortisers (sometimes called “hollow-chisel mortisers”) cut mortises faster—and cleaner—than drilling a row of holes and cleaning up the mortise with a chisel. Drill-press attachments work fine for occasional use or for mortises smaller than $\frac{3}{8}$ ", but most drill presses aren't designed to provide the pressure and leverage required to plunge a larger bit and chisel into hardwoods.

Be aware, though, that benchtop mortisers (and drill-press attachments) fall short when it comes to boring through-mortises. Despite our best efforts to control tear-out as the chisel/bit exits the wood, we've found the results unacceptably rough. Often, though, that tear-out will be hidden by the shoulders of the mating tenon.

5 key buying considerations

1 Motor speed. All of the machines in our test displayed ample power to cut mortises, but some do the job faster than others. The reason: Five units spin the bit at speeds of about 1,720 rpm, while the Bridgewood HM-11 and Shop Fox W1671 run about twice as fast, with speeds of 3,400 and 3,450 rpm. Some woodworkers disdain high-speed machines, arguing that the auger bit overheats easier, causing it to lose its temper and not hold a sharp edge. In our shop tests, though, we measured little difference in auger-bit temperatures between high-speed and low-speed machines after boring a 4"-long mortise, as shown at *right*.

We did find a significant difference, however, in the amount of time it took to make that same mortise with each of the machines. In hardwoods, the high-speed mortisers did the job in about half the time of the slow-speed machines. We noticed, too, that the slow machines were more prone to stalling in hardwoods, often caused by an errant wood chip getting trapped between the bit and chisel.

How a mortiser drills square holes

Yes, you can drill a square hole with a round bit. Here's how: An auger-type drill bit spins inside a hollow four-sided chisel secured to the mortiser. The bit itself locks inside the head of the machine. When you pull down on the mortiser's feed lever, the bit and chisel plunge simultaneously into your workpiece.

Like all drill bits, the auger bit bores a hole and ejects the chips. Meanwhile, the four sharp edges of the chisel pare the wood around the bored hole into a square shape. The auger bit removes this waste, as well, through a chip ejection slot in the chisel. To learn more about bit/chisel sets and how to get the most out of them, see “5 things you need to know about hollow mortise chisels” on *page 100*.

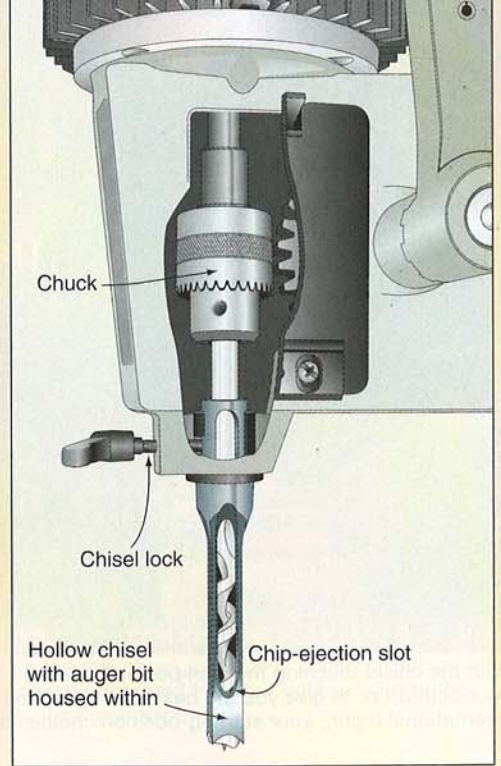

2 Plunging action. Here's where the benchtop mortisers have it all over drill-press-mounted attachments. A long handle means more leverage, and Shop Fox's 22" handle is the longest in the test, followed by the 21" handles on the General International

machines. These three mortisers also have a horizontal “L” grip (shown on the *next page*), making them easier to operate through their full range of motion.

We also prefer multi-position handles that you reposition to gain a more comfort-

3,450 RPM MOTORS WORK FASTER, BUT NOT NECESSARILY HOTTER THAN 1,725 RPM MOTORS

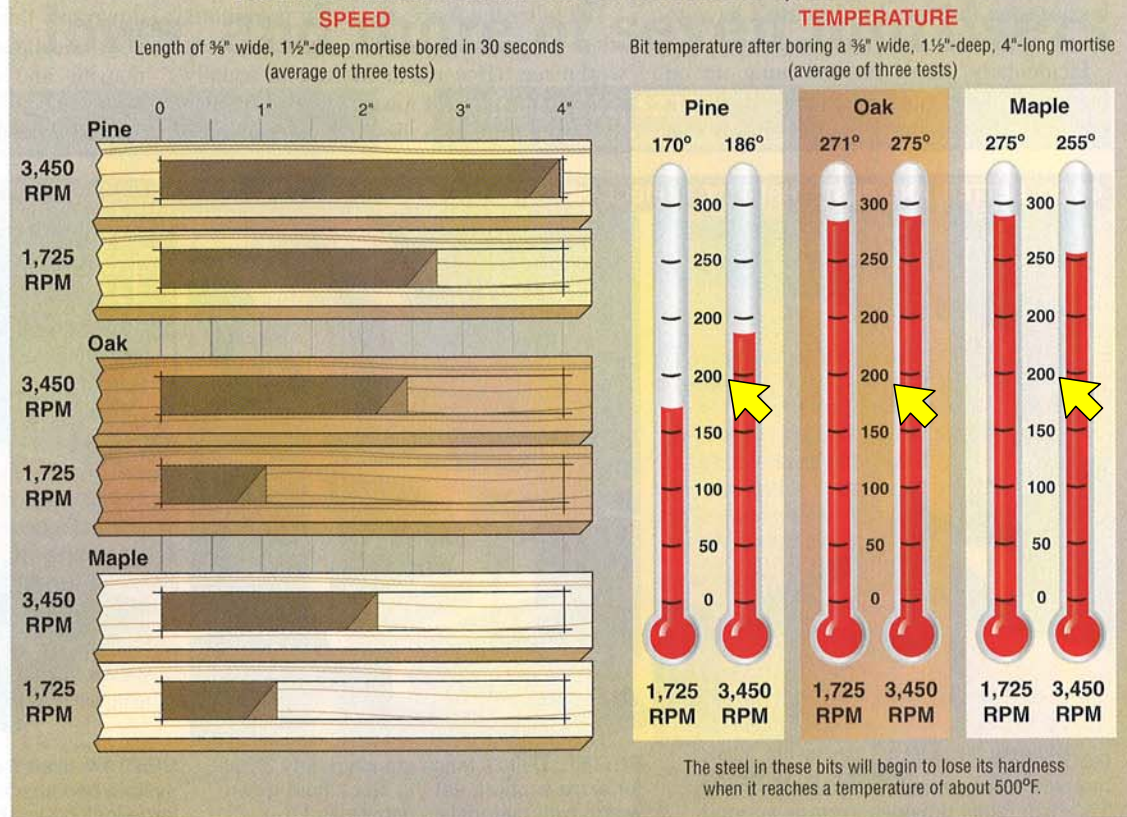

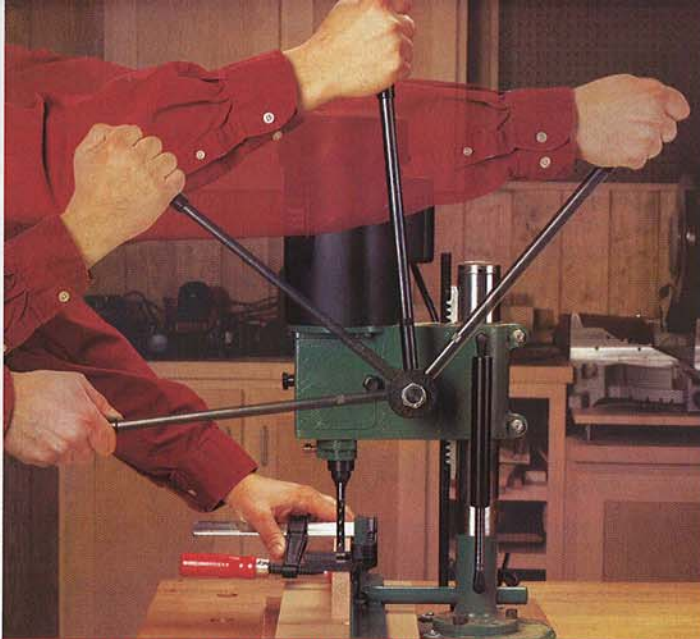

MULTIPLE HANDLE POSITIONS MAXIMIZE LEVERAGE

With the chisel touching the workpiece, the handle of the Bridgewood mortiser (*left*) can be placed in any of four positions (every 45°) to suit your comfort or to give you the best leverage. (We prefer the straight-up position for starting.) With the two-position handle of the General International (*right*), your starting-position choices are limited to reaching behind the machine or making only a shallow cut.

able or advantageous starting point, regardless of the thickness of your workpiece, length of chisel, or depth of mortise. The photos *above* demonstrate the importance of these handles.

All of the tested mortisers employ a reliable depth stop to ensure consistent cutting depth, but only three (the Fisch and both General International models) also have a top stop to limit upward travel of the head. That feature saves you both time and energy because the mortiser head doesn't have to return to its full height after each cut.

Incidentally, don't get too hung up on buying the longest stroke (plunge depth) in the test. Most hollow mortise chisels can

cut only 4–5" deep, so any stroke capacity more than that is overkill.

3 Fences and hold-downs. A mortiser's fence fixes the distance between the mortise and the edge of the workpiece, and all proved reliable and square to the tabletop. Fence locks on the two machines that have microadjusters (Fisch and Shop Fox) were difficult to access, while Delta's rack-and-pinion mechanism offers fast, but not fine, fence adjustments.

The taller the fence, the better it supports when you're mortising the edge of a wide workpiece. (Because a mortise is usually made in the edge of a workpiece, we'll use the term *width* to describe the vertical

dimension.) However, in most cases, the fence height also dictates the minimum width of workpiece you can mortise. Only the recessed fences on the Delta (shown *below center*) and General International mortisers allow the hold-down to go lower than the top of the fence.

Workpiece hold-downs on nearly all of the mortisers we tested are made of cast iron, a sometimes rough surface that can mar your workpiece. (Setting the hold-down two thicknesses of paper higher than your workpiece virtually eliminates the marring and still allows you to slide the workpiece as you lengthen the mortise.) The General International machines stand

GOOD, BETTER, AND BEST: THREE WORKPIECE-HOLDING SYSTEMS

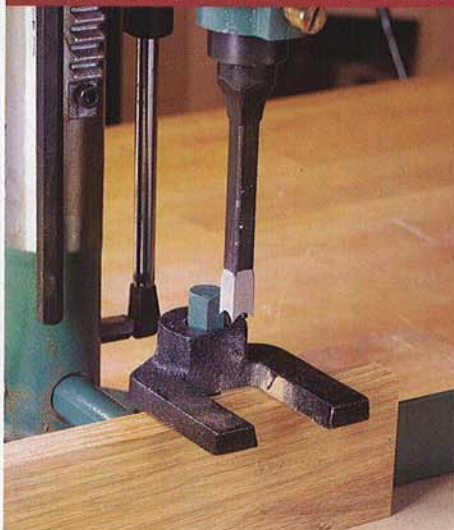

GOOD: Bridgewood's stock hold-down requires a hex wrench to secure it. And its 1½"-high fence provides average support.



BETTER: Delta's fence stands nearly 3" tall for extra support, yet the stock hold-down works with material as narrow as 1".

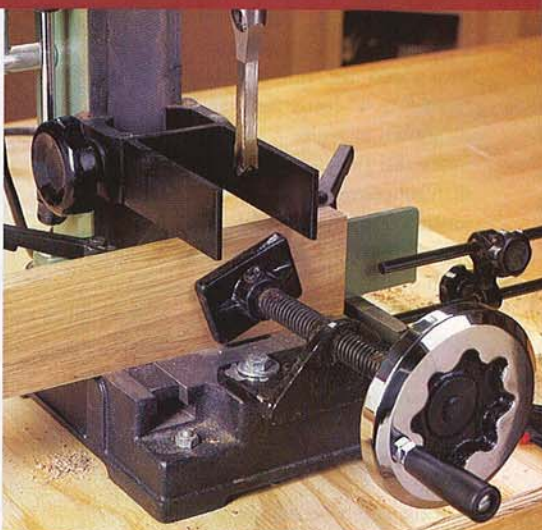

BEST: We liked General International's holding system because of its column-mounted hold-down, large locking knob, and handwheel stock clamp.

SOME MACHINES MAKE THE CHORE OF CHANGING BITS AND CHISELS LESS CHALLENGING



General International's handy ratcheting lock secures the chisel. The rest of the mortisers require a wrench or screwdriver.



Jet's long chuck key and wide-open access to the drill chuck (left) make it easy to secure bits. By contrast, Bridgewood's chuck (right) can only be operated from the right or front of the machine, and the handle of the chuck key hits the cover knob.

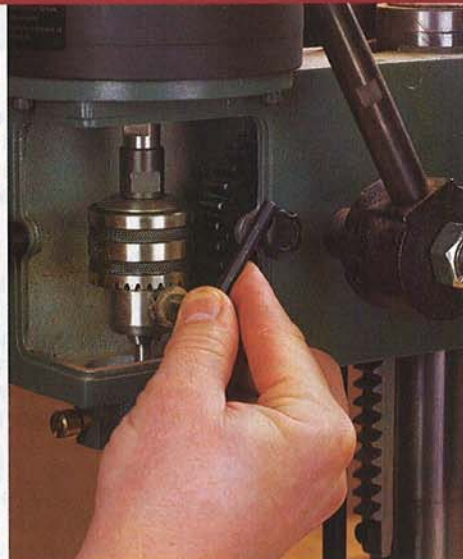

out here for a couple reasons. First, the long "fingers" on the hold-down keep workpieces from twisting as you pull the chisel out of them. Second, the hold-down locks with a large handwheel rather than a ratcheting knob or hexhead screw.

4 Changing chisels and bits. The General International mortisers make this task as tool-free as possible (see photo above), requiring only a chuck key to install

the bit. Delta's hexhead wrench is on one end of the chuck key, making that the only tool needed for bit and chisel changes. Jet's chuck key (shown above) is the longest, reaching easily inside the mortiser's head to tighten and loosen the chuck; Bridgewood's (top right photo) is the shortest, and a real knuckle-banger.

5 Workpiece capacities. The true capacities of these machines are tough to nail

down, because hollow-mortise chisel lengths vary from size to size and brand to brand. The "Maximum Distance From Bushing to Table" column in the chart at the end of this article gives a comparative indication of each mortiser's true capacity. To learn a machine's capacity for a particular chisel, subtract the length of the mortise chisel (our 3/8" chisel, for example, was 4 1/4" long) from the dimension listed in the chart.

The highs, lows, and more of seven mortisers

Bridgewood HM-11, \$190

800/235-2100, wilkemach.com

High points

- ◆ The high-speed motor cuts mortises faster than the slow-speed motors found on most other models.
- ◆ Four possible handle positions for each mortise allow the user to choose the most comfortable or advantageous one.

Low points

- ◆ Short handle means more muscle is required to cut 1/2" or wider mortises.
- ◆ Short chuck key makes bit changing difficult, and access is limited for left-handed users.
- ◆ No chisels included in purchase price.
- ◆ The only mortiser that requires a hexhead wrench to set the cutting-depth stop.
- ◆ No onboard storage for adjustment tools.

More points

- ◆ A good performer, but strictly barebones compared to the other machines.



Delta 14-651, \$230

800/438-2486, deltamachinery.com



High points

- ◆ Hexhead wrench on chuck key makes for one-tool bit/chisel changes.
- ◆ The unique rack-and-pinion fence mechanism makes for silky-smooth adjustments to the fence location.
- ◆ Large cast-iron table/base provides a broad, stable work surface, enabling you to mortise into the face of wide workpieces.
- ◆ Cutout in fence allows the hold-down to work with pieces as narrow as 1".
- ◆ Head rotates to mortise off the table.
- ◆ Onboard storage for all adjustment tools.
- ◆ Four chisels included in purchase price.

Low points

- ◆ Straight handle grip is not as ergonomic as horizontal grip found on some machines.

More points

- ◆ Included riser block and extra-long hold-down post add 1 1/4" of workpiece capacity when you need it, but defeats the rack-and-pinion fence adjuster when installed.





High points

- ▲ Top stop on depth stop limits upward travel of the head, saving you both time and energy.
- ▲ Onboard storage for all adjustment tools.

Low points

- ▼ Straight handle grip is not as ergonomic as horizontal grip on some other machines.
- ▼ Strong head-return spring works against you, especially when cutting deep or wide mortises.

More points

- ▶ Microadjustable fence makes it easy to fine-tune a mortise location, but the locking knob is awkward to use.



High points

- ▲ The best workholding system in the test, with a substantial hold-down and a screw clamp.
- ▲ Cutouts in fence allow hold-down to secure workpieces narrower than the fence is tall. The fence also features a scale showing its distance from the center of the mortise.
- ▲ Besides a depth-of-cut stop and a top stop to limit upward head travel, this machine also has a mortise-length stop.
- ▲ Long handle for better leverage and horizontal grip for operator comfort.
- ▲ Four chisels included in purchase price.

Low points

- ▼ Two-position handle limits your choice of starting points to optimize leverage.
- ▼ Onboard storage for chuck key, but not for adjustment tools.
- ▼ Instruction manual is vague, assuming too much knowledge on the part of the user.

More points

- ▶ If you don't need to make angled mortises, or work off the table, this is the best in the bunch.

SEVEN BENCHTOP MORTISERS, MAKING THE GRADE

BRAND	MODEL	HP	SPEED	MOTOR				CAPACITY (INCHES)					CONSTRUCTION					HANDLE	PERFORMANCE GRADES (7)						
				MINIMUM WORKPIECE WIDTH UNDER HOLD-DOWN	MAXIMUM DISTANCE FROM BUSHING TO TABLE (1)	CHUCK	MAXIMUM DISTANCE FROM FENCE TO CHISEL CENTER	STROKE (2)	MAXIMUM CHISEL SHANK SIZE	TABLE MATERIAL (3)	TABLE SIZE (LxW, INCHES)	BASE DIMENSIONS (DxW, INCHES)	COLUMN CONFIGURATION (4)	LENGTH (INCHES)	STYLE (5)	NUMBER OF POSITIONS (6)	CHUCK ACCESS		CHISEL CHANGING EASE	DEPTH STOP EFFECTIVENESS	HOLD-DOWN EFFECTIVENESS	HOLD-DOWN ADJUSTMENT	FENCE ADJUSTMENT		
BRIDGEWOOD	HM-11	1/2	3,400	1 5/8	8 1/8	3/8	3 1/2	4 1/2	5/8	MDF	13 1/2 x 6	7 1/2 x 12	F	16	S	4	C	B-	B-	B+	B	C+			
DELTA	14-651	1/2	1,725	1	8 3/8	3/8	3 3/4	4 5/8	1/2	CI	12 1/4 x 8 1/4	13 1/2 x 16 1/4	R	18	S	3	A	B+	B	B+	B+	A-			
FISCH	BTM99-44252	3/4	1,725	1 1/2	7 3/4	1/2	2 3/4	4 3/8	1/2	MDF	13 1/2 x 6	7 3/4 x 10 1/4	F	18	S	3	A	B	A	B+	B	A			
GENERAL INTERNATIONAL	75-050 M1	1/2	1,720	1	10 1/8	1/2	3	6	3/4	CI	7 1/2 x 5	7 x 11 1/2	F	21	H	2	A-	A	A-	A-	A-	B+			
	75-050 T	1/2	1,720	1 3/8	10	1/2	3	6 3/4	3/4	CI	8 x 8	8 3/4 x 14	TR	21	H	2	A-	A	A-	A-	A-	B+			
JET	JBM-5	1/2	1,720	1 3/4	8 1/8	3/8	3 1/8	4 5/8	1/2	MDF	12 1/4 x 7 1/2	7 5/8 x 12 1/2	R	16	S	3	B+	B-	B	B	B+	C+			
SHOP FOX	W1671	3/4	3,450	2 1/8	13 1/8	1/2	4	4 3/4	3/4	MDF	16 x 6	11 x 14	R	22	H	3	A	B	B	B	B	A			

NOTES: 1. Subtract the length of the mortise chisel from this dimension to determine the mortiser's capacity. Chisel lengths vary by diameter and manufacturer.
 2. Maximum plunging distance of the chisel.
 3. (CI) Cast iron (MDF) Medium-density fiberboard
 4. (F) Fixed column (R) Column rotates (TR) Column tilts and rotates
 5. (H) Horizontal grip (S) Straight grip
 6. Within the range of the user's reach.
 7. A Excellent B Good C Fair D Poor

These machines mortise to the max

Although we prefer fast-cutting high-speed mortisers, we found the rugged construction and user-friendliness of the General International 75-050 T impossible to resist, so it's our Top Tool. True, it's the most expensive machine in the test, and it lacks a multi-position handle. But the solid hold-down, fence

scale, front-mounted clamp, length stop, and tilting head are features normally found only on industrial-grade mortisers that cost twice as much. And, aside from chucking the auger bit, every routine adjustment on this machine is performed without the use of a single tool. Don't need the tilting, rotating head? The General International 75-050

M1 is nearly the same machine, except for those functions, for \$40 less.

Our choice for Top Value was tougher, with a virtual tie between the Delta 14-651 and the Shop Fox W1671. We like Shop Fox's powerful high-speed motor, with which we bored cleanly—and quickly—into oak and maple without stalling. Figure

General International 75-050 T, \$340

514/326-1161, general.ca



High points

- ◆ This machine has all the great features found on the 75-050 M1: excellent stock hold-downs and fence; depth, top, and length stops; and a long handle with horizontal grip.
- ◆ The head of this mortiser tilts to make angled mortises, such as those in chair legs and back splats. It also rotates (without using tools) for off-the-table mortising.
- ◆ Large cast-iron base provides a broad, stable work surface.
- ◆ Four chisels included in purchase price.

Low points

- ◆ Same low points as General International 75-050 M1.

More points

- ◆ This mortiser can do it all, and do it well, so it's our choice for Top Tool.

Jet JBM-5, \$200

800/274-6848, wmhtoolgroup.com



High points

- ◆ No tools needed to secure fence and hold-down.
- ◆ Long chuck key makes tightening and loosening the drill chuck easy.
- ◆ 3"-long fingers on hold-down are about 1" longer than most to better stabilize thick workpieces.

Low points

- ◆ Short handle means more muscle is required to cut 1/2" or wider mortises.
- ◆ Straight handle grip is not as ergonomic as the horizontal grip found on some machines.
- ◆ Onboard storage for chuck key, but not for adjustment tools.

More points

- ◆ Head rotates to mortise off the table, but the machine must be unbolted from the bench to do so.
- ◆ Optional riser block (\$20) boosts workpiece capacity by 2".

Shop Fox W1671, \$230

800/840-8420, shopfox.biz



High points

- ◆ The high-speed motor cuts mortises faster than the slow-speed motors found on most other models.
- ◆ Long handle for better leverage, and horizontal grip for operator comfort.
- ◆ Big-capacity machine: Bores to the center of an 8" workpiece, and the head and hold-down can be quickly reconfigured to mortise pieces about that wide (both best in the test).
- ◆ Large cast-iron base provides a stable work surface.

Low points

- ◆ Only one chisel included in purchase price.

More points

- ◆ Microadjustable fence makes it easy to fine-tune a mortise location, but the locking knob is awkward to use.
- ◆ Head rotates to mortise off the table, but the machine must be unbolted from the bench to do so.

				ACCESSORIES (8)							
TABLE/FENCE SQUARENESS	TOOL STORAGE	OVERALL EASE OF USE	QUALITY OF MANUAL	CHISELS INCLUDED (INCHES)	STANDARD	OPTIONAL	CORD LENGTH	WARRANTY (YEARS)	COUNTRY OF ASSEMBLY (9)	WEIGHT (POUNDS)	SELLING PRICE (10)
A-	D	B	B+		B, SX		6'	1	T	50	\$190
A	A-	A-	A-	1/4, 5/16, 3/8, 1/2	H, R, SX, T		6'	2	C	55	230
A-	A	B+	B	1/4, 3/8, 1/2			6'	2	C	66	240
A	C	A-	C	1/4, 5/16, 3/8, 1/2	B, S		5'6"	2	T	76	300
A	C	A-	C	1/4, 5/16, 3/8, 1/2	B, S		5'6"	2	T	98	340
A-	C	B	B	1/4, 3/8, 1/2	B, SX, T	R	6'	2	T	53	200
A-	B+	B+	A-	1/2	B, H, T		9'6"	2	C	92	230
8.				(B) Bushing for 3/4" chisel (H) Hold-down extension (R) Riser block (S) Length stop (SX) Spindle extension (T) Tool caddy	9.		(C) China (T) Taiwan	10. Prices current at time of articles production and do not include shipping, where applicable.			

on adding another \$40 or so to the price to get a full set of chisels, though. Delta includes all the chisels you're likely to need, comes nicely appointed with a rack-and-pinion fence and riser block, and all routine adjustments are made with the chuck key. If you don't mind its slower speed, this mortiser is a great value. 🌲

Written by Dave Campbell with Jeff Hall

Share your opinion

of these mortisers in our Interactive Tool Review at

woodmagazine.com/mortisers



getting a grip on **four-jaw lathe chucks**



Teknatool of New Zealand started the woodturning chuck revolution in 1988. Shown above is the business end of its Nova Titan chuck.

When first introduced, four-jaw chucks were viewed by many as a luxury just for professional turners. But they offer so many advantages that anyone from novice level on up would benefit from owning one.

With prices ranging from about \$35 up to \$280, you're probably asking yourself why you should buy a four-jaw chuck for your lathe. Here are some of the best reasons:

- Chucks provide quick, accurate, and positive centering of bowl blanks and standard turning squares.
- There's no need to glue a waste block to your turning blank or give up bowl-blank thickness to accommodate the screws needed to fasten it to a faceplate.

■ When using a chuck to turn a bowl from green stock, you can rough it out, remove it from the lathe, and then later remount it with greater ease and convenience than with faceplate mounting.

■ Accessory chuck jaws are available to hold work as small as a 1/4"-diameter tenon on a miniature vessel and as large as the rim of an 18"-diameter platter.

■ You can turn a bowl and finish it inside and out with little or no trace of how it was held on the lathe.

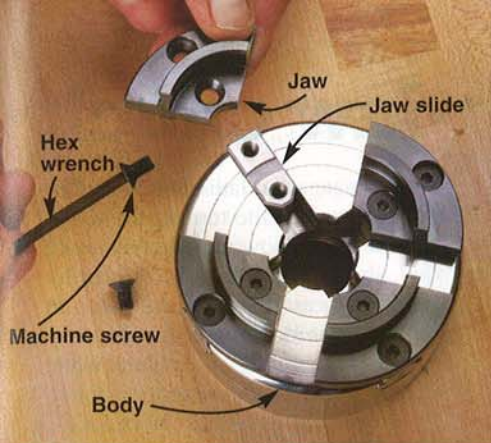

KEY CHUCK PARTS

The chuck jaws attach to the jaw slides with machine screws, allowing the use of a wide variety of specialized accessory jaws.

How a chuck works

A chuck consists of a **body**, **jaw slides**, and **jaws**, as shown *above*. Internal spiral gearing moves all four jaws simultaneously, keeping them equidistant from the center of the chuck body. The jaws operate with twin levers or a single key. Lever action requires either the simultaneous use of both hands, or temporarily locking the lathe spindle to adjust the chuck with one lever. Single-key chucks offer the advantage of one-hand operation without the necessity of locking the lathe spindle. One-hand tightening or loosening leaves the other hand free to control stock when mounting it or a finished piece when removing it from the chuck.

Jaw design

There are two basic jaw designs, dovetail and serrated, as shown *below*. Most jaws for Vicmarc and Axminster chucks are of the dovetail design. The flanged SuperNova jaws are a variation of this design. Serrated jaws are most common on Oneway chucks.

HOW FAR YOU OPEN A CHUCK AFFECTS ITS GRIPPING POWER

(Chuck viewed straight on looking toward the headstock)

JAWS NEAR MINIMUM OPENING PROVIDE MAXIMUM GRIP

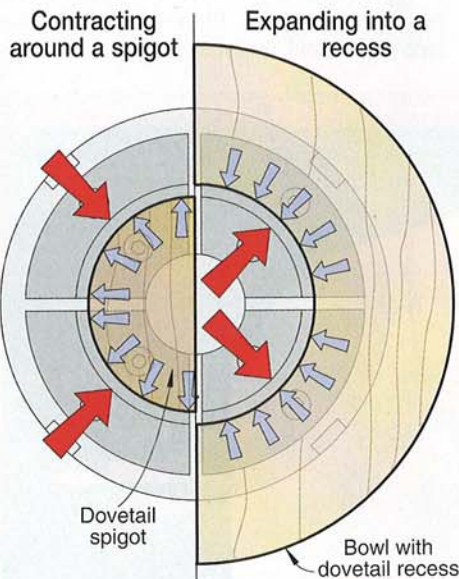

JAWS NEAR MAXIMUM OPENING PROVIDE LESS GRIP

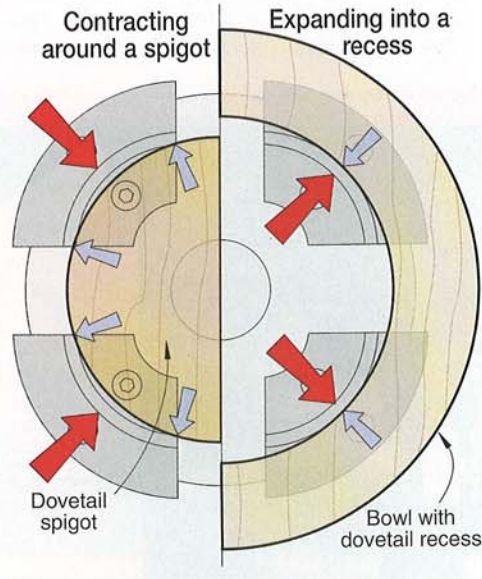

→ Jaw motion **⇨ Workpiece point of contact**

How a chuck grips

Chuck jaws either contract around a turned spigot (round tenon) or expand into a hollowed-out recess. In contracting mode, the jaws commonly supplied with chucks grip spigots from 1½" to 3" in diameter. These same jaws expand into turned recesses from 2" to 3½" in diameter.

Because chuck jaws form a circle when completely closed, they make continuous contact when contracting around a spigot or expanding into a recess that is just slightly larger than the diameter of the circle, as shown *above*. This provides the greatest

holding power and safest operation. As the jaws approach their maximum open position they make only point contact with the workpiece, as shown *above*. Gripping only at these points (eight in contracting mode, or four in expanding mode) is less secure and risks marring the wood. Manufacturers offer accessory jaws to cover a wide range of gripping diameters.

When turning, be careful of chuck jaws adjusted near their maximum diameter. The farther open the jaws, the more they extend beyond the chuck body, and if touched, the more likely they are to cause injury.

TWO JAW TYPES GIVE YOU DIFFERENT ADVANTAGES



Dovetail jaws usually leave minimal or no marking on the finished vessel, reducing the need to remount it to remove any marks.

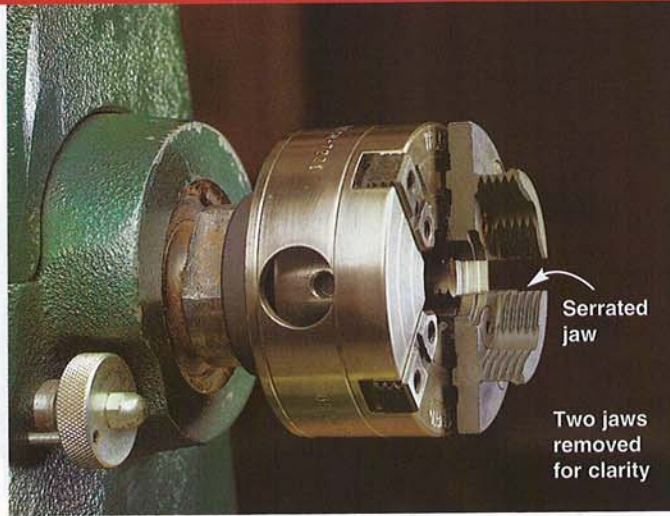

Serrated jaws have great holding power, particularly when gripping end-grain stock, but leave marks that must be removed.

Turning a bowl with a four-jaw chuck

Start on the outside

For mounting side-grain bowl blanks, many chucks come with a screw center. To use this center, install it in the chuck by grip-

ping it with the jaws. Drill a hole equal in diameter to the root of the screw and slightly deeper than its length, centered on the top face of the blank. Then thread the blank onto

the screw. Engage the lathe tail center for additional support while turning the rough shape of the bowl. Now turn the outside of the bowl, shaping its bottom to be held by the chuck jaws, as shown in the photo at left. Screw-center mounting allows for easy removal and remounting of the blank while maintaining its centered position.

FIRST, MOUNT THE BLANK ON A SCREW CENTER, AND SHAPE THE OUTSIDE

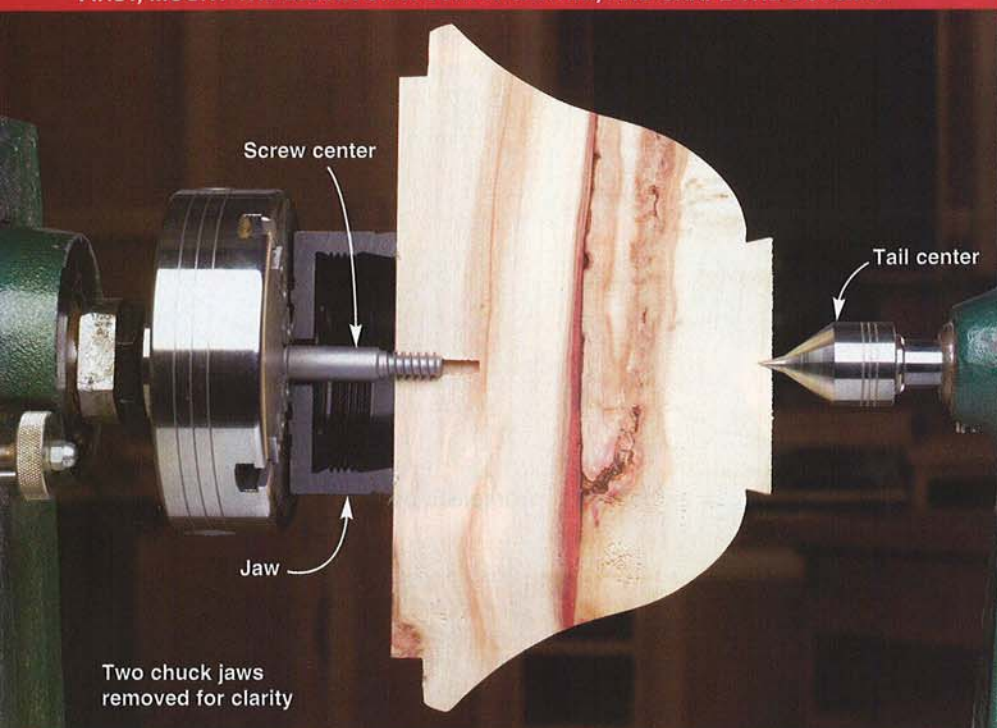

With its exterior shaped, this partially formed bowl was cut in half to show how the screw center secures it to the chuck.

Shape the bottom

When shaping the outside of a bowl, form its bottom to fit your chuck jaws so you can reverse the blank, grip it with the chuck, and form the inside. For contracting dovetail jaws, form a dovetail spigot as shown below left. Cut the inside corner where the spigot meets the bowl body crisp and clean to provide a positive gripping corner for the chuck jaws. Leave a flat bearing surface for the jaw ends. Because the jaws pull in on the spigot as well as squeezing it, make the spigot slightly shorter than the jaw depth, so it does not bottom out. Sand and finish as much of the outside of the bowl as possible.

The same jaws that contract onto a spigot also will expand into a recess hollowed out in the bottom of a bowl, as shown below. When planning the shape of your bowl, leave extra thickness in its bottom to accommodate this recess. Make it about $\frac{1}{8}$ – $\frac{1}{4}$ " deep, cleanly cut, and with its edge following the shape of the jaws. Leave sufficient

THEN, GRIP THE BOWL BOTTOM IN ONE OF TWO WAYS, AND FORM THE INSIDE

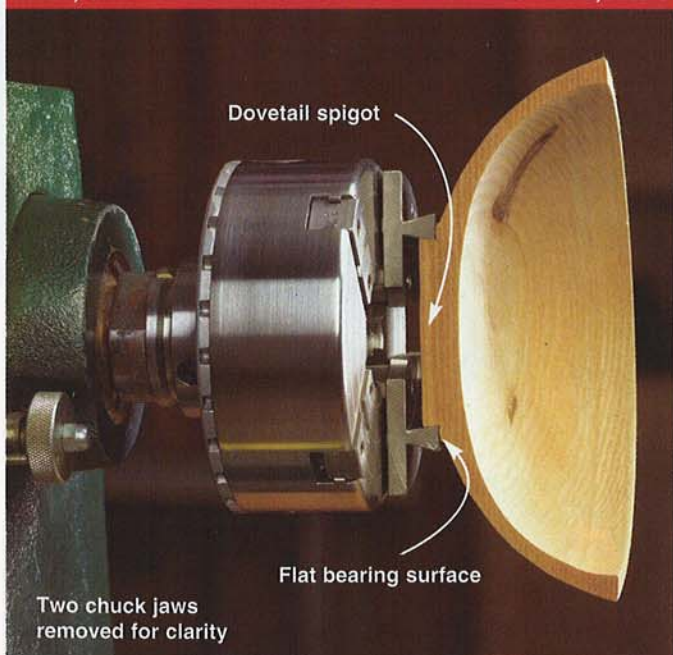

Dovetail jaws contracting around a spigot: When forming a spigot at the bottom of a bowl, match the angle of the outside edge of the spigot to the angle of the jaws.

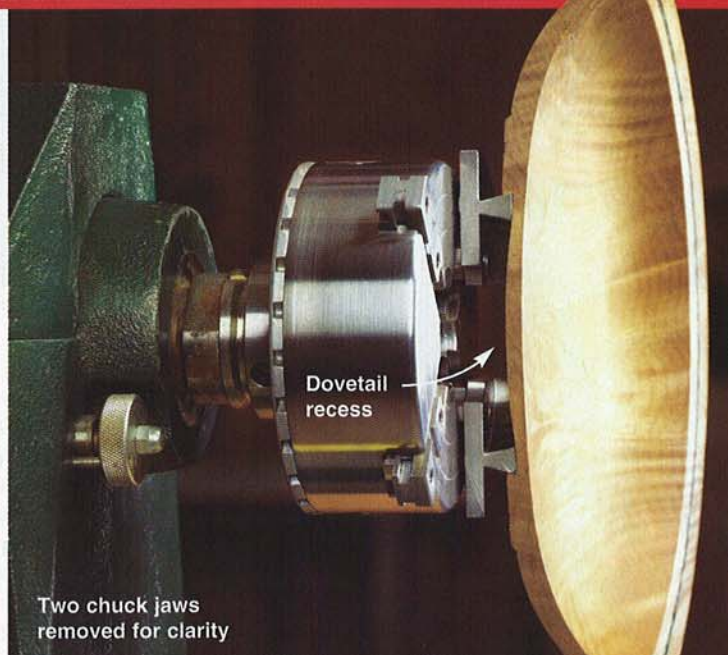

Dovetail jaws expanding into a recess: When forming a recess in the bottom of a bowl, match the angle of the inside rim of the recess to the angle of the jaws.

BOWL JAWS MAKE IT EASY TO REMOVE A SPIGOT

wood around the recess to support the outward force exerted by the expanding jaws. Gripping the bowl in this manner allows you to completely form the outside, including its bottom. With the outside of the bowl formed, sand it and apply a finish.

Generally speaking, contracting onto a spigot provides the greatest holding power. However, for turnings of large diameter but shallow depth, such as a large platter, expanding into a recess gives better results. Regardless of how the chuck holds the workpiece, be sure to periodically check its tightness.

Now form the inside

With the outside of the bowl complete, remove it from the screw center, and remove the screw center from the chuck. To hollow the inside of the bowl, remount it as shown, *opposite page, bottom*. When turning the inside, take care not to catch the tool. Chucks do not hold turning stock as securely as a standard faceplate where several screws secure the blank. A bad catch can dislodge the bowl from the chuck. Once the final inside shape and wall thickness of the bowl have been achieved, sand it and apply the finish. For a bowl gripped in a recess, simply remove it from the chuck.

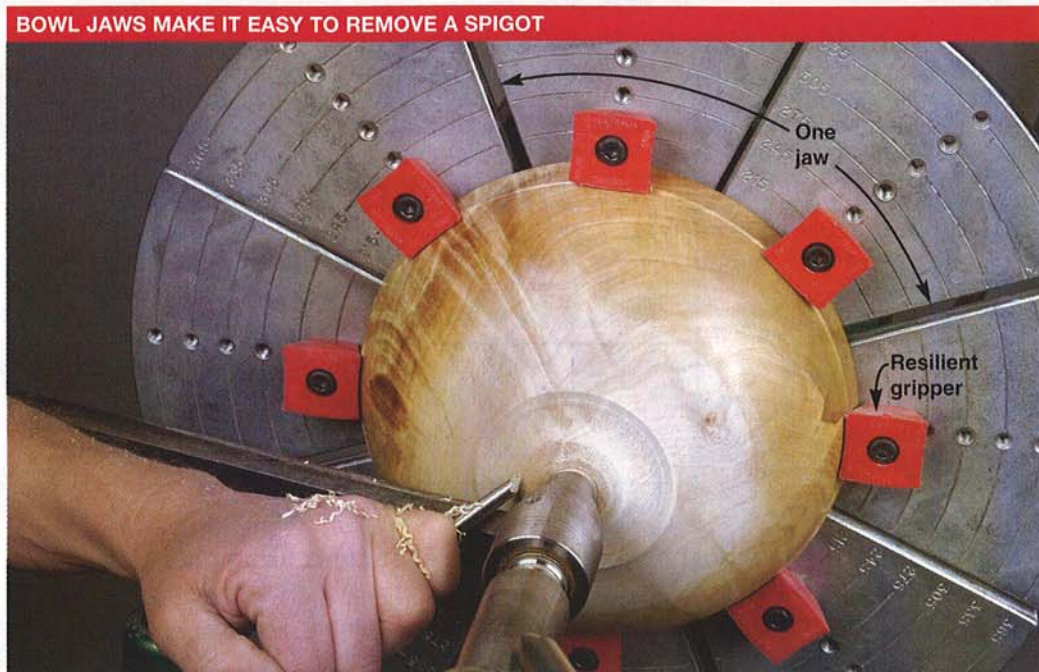

Christensen/Burningham

Although each manufacturer has a different name for this chuck accessory, adjustable bowl jaws all work the same. Resilient grippers hold the bowl rim to the chuck jaws. Sets cost from \$50 to \$140.

Back to the bottom

For a bowl gripped by a spigot, reverse-chuck it, gripping the rim with a shop-made jam chuck or accessory adjustable bowl jaws, as shown *above*. Then turn away the spigot, and form a slight recess in the bottom of the bowl. Whether using a jam chuck or a four-jaw chuck fitted with bowl jaws, support the workpiece with the tail center for as long as possible. Finish-sand the turned area, and apply a finish. 🌲

Sources

Woodturning chucks.

Packard Woodworks. Call 800/683-8876, or go to packardwoodworks.com.

Grizzly Industrial. Call 800/523-4777, or go to grizzly.com.

Penn State Industries. Call 800/377-7297, or go to pennstateind.com.

Craft Supplies, USA. Call 800/551-8876, or go to woodturnerscatalog.com.

Coming in issue 159. See Wise Buys in this upcoming issue for reviews of four chucks priced from about \$35 to \$235.

A chuck also grips square stock

Chucks also can grip most common sizes of turning squares. Because square stock cannot be held as securely as round stock, hold it with the chuck and support it with a tail center, as shown at *right*. Then turn a round spigot on the tailstock end. Now flip the square end for end, and grip the spigot in the chuck, once again supporting it with the tail center. When you cut square stock for mounting in a chuck, make accuracy a priority; out-of-square stock is difficult to grip securely. The slightly rounded jaw corners of Oneway chucks offer the best design for gripping square stock.

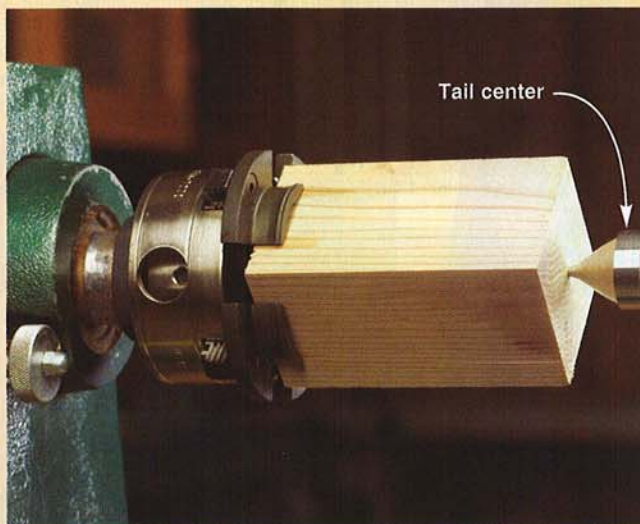

Meet the authors

This article was produced with the help of Kip Christensen and Rex Burningham. Kip teaches furniture design and prototyping at Brigham Young University in Provo, Utah. He frequently demonstrates turning techniques at national symposia and workshops.



Kip Christensen



Rex Burningham

Rex teaches turning at Craft Supplies USA, also in Provo. He exhibits his work in galleries and craft shows, and has assisted such legendary turners as Richard Raffin, Rude Osolnik, Dale Nish, and Ray Key.

Illustrations: Roxanne LeMoine

Here they are, the WINNERS in our 2004

rugged 'n' ready TOOL STORAGE CONTEST

Readers roll out their most inventive solutions for controlling clutter.

We teamed with Chevy Silverado and DeWalt Tools to rustle up the best storage ideas in the nation during our 2004 "Rugged 'n' Ready Tool Storage Contest." After pouring through the many deserving entries, the judges (Bill Krier, editor-in-chief; Marlen

Kemmet, managing editor; Kevin Boyle, senior design editor; and Jan Svec, projects editor) chose 13 winners: 1 grand prize, 2 runners-up, and ten judges' choice awards. Some are pretty, others just practical, but all offer creative solutions for workshop storage.



★ GRAND PRIZE ★ \$2,500 cash from Chevy Silverado

Tag-along tool tote

Kevin Hall of Tremonton, Utah, drew inspiration from a rolling carry-on suitcase to create on-the-go storage for the tools and supplies he needs for household repairs and chores outside the shop. Just like the airline version, his features sturdy wheels and a retractable handle. The lid flips up and L-shape sides swing open wide to brace the tote and provide access to the tools and accessories inside. Custom holders keep everything in place while on the roll, and a removable tray holds screws and hardware.

We liked Kevin's idea so much that we'll bring you complete plans for our version in the next issue.



Open the tote wide for easy access to tools and accessories ...



... latch the lid and doors for secure transport ...



... and slide down the locking handle for compact storage.

★ **FIRST RUNNER-UP** ★
\$1,500 cash from Chevy Silverado

Flip-up platforms for benchtop tools

Randy Kough's 12x16' shop in Deltona, Florida, quickly became cramped when outfitted with a full complement of benchtop tools. To save space, he made hinged platforms that hold the machines upside down and out of the way under the bench. When flipped up, a single leg mounted to a strap hinge supports each plywood platform. Sometimes simple is best, and that's why Randy's low-cost solution caught our judges' attention.

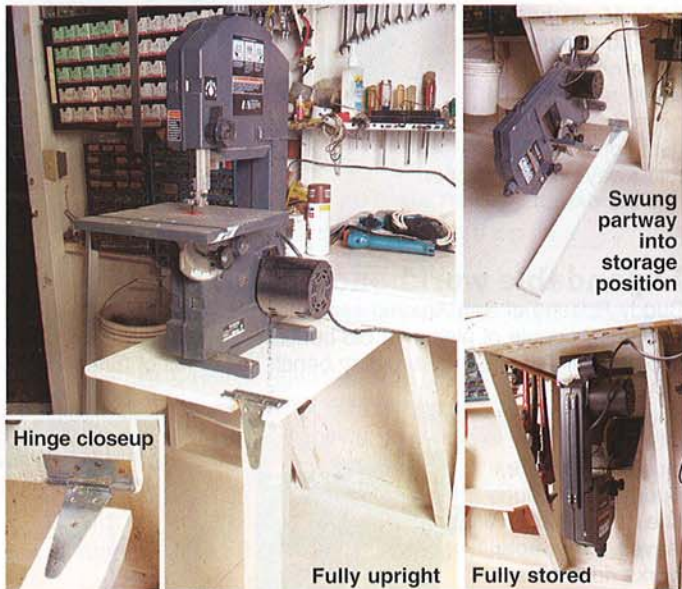

★ **SECOND RUNNER-UP** ★
\$1,000 cash from Chevy Silverado

Four-door clamshell corner cabinet

Dick Carlson of Ridgefield, Washington, wanted to keep the dust off his shelves, so he added a door. Then his creativity kicked in, and he designed four doors. Each holds tools on hooks, and every door is narrower than the next. They're mounted to a stair-step-shape block so each opens to a full 90°. He categorized the tools on the doors, making them easy to find. Over 250 tools now reside in this cabinet that takes almost no shop space at all.



★ **JUDGES' CHOICE AWARDS** ★

We knew we couldn't narrow the field to just three winners, so our judges awarded prizes to the 10 next best. Each of these lucky woodworkers gets to find storage space for about \$500 worth of DeWalt tools.



DW735 thickness planer



OR DW433KT belt sander + DW618B3 router kit

Bench-side tool chest

Jeff Bradford added loads of storage space alongside the bench in his Seabrook, Texas, shop. But he didn't stop there. Using carving and intarsia, he turned the chest into a thing of beauty. Made mostly of mahogany (solid and plywood), the chest sports a 1½" maple butcher-block top. Jeff even included a tote box that he can use to carry tools needed for jobs outside the shop.



Multi-task tool organizer

Bob Reid got tired of chasing tools and accessories all over his Savage, Minnesota, workshop, so he corralled them in this cabinet. Drawers offer ample storage while cubbies accommodate portable power tools. Bob wheels the organizer to any of his tools needing its built-in stock support roller.



No-spill screw box

Larry Miller of Olympia, Washington, keeps his corded and cordless drills, bits, and an ample supply of screws in one portable box that measures less than 10x13x17". Made mostly from scrap wood, the box houses two trays that rise on aluminum arms. The top tray nests on the lower unit and features a hinged lid to prevent screw spills.

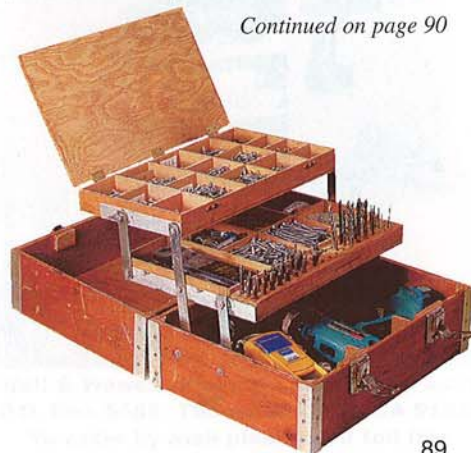

Right-height work table

Russell Zirngible of Owatonna, Minnesota, built his rolling "do-it-all table" to provide storage, an assembly surface, and outfeed support in one compact package.

The tops supports are marked with various heights for quick outfeed setup at various machines. Slide-out trays store tools behind hardboard doors, and electrical outlets put power close at hand.



Photograph: Mike Oldenburg

Mobile tablesaw center

This heavy-duty saw station enables Daniel Rabinovitz of Murrysville, Pennsylvania, to wheel his tablesaw and accessories onto his gravel driveway,

where he does most of his woodworking. The large pneumatic tires make it easy to roll while 15 storage drawers and compartments place needed tools within reach. Daniel even incorporated dust collection and a fold-away outfeed support into the design.



Photograph: K and G Enterprises

Race-ready tool transport

Machinist Frank Buddell of Lansing, Illinois, created this racy looking toolbox

for his son, Mike, to store his own machinists' tools at work. It has 21 drawers on heavy-duty slides, a bin underneath, and a butcher-block top. Go-kart suspension parts create the high-performance wheelset.



Photograph: Bill Swain

Expandable workbench

Buddy Rosene of San Antonio combined a cast-off card file cabinet, a couple of pieces of old benchtop, and dining-table equalizer slides into a heavy-duty bench chock-full of functional storage. When he needs a bit more work space,

Buddy simply adds one or two more leaves. The whole works rides on a mobile base.



Photograph: Michael Connally

Rolling tool tower

Marc Aronson of Chatsworth, California, fit a shopful of small items into a 2'-diameter, 54"-tall tower. Tools and supplies mount on all four outer sides while one side hinges open to reveal slide-out trays. On these, Marc stores bits, blades, tool cases, and more. The tower features a lazy Susan that locks onto the caster-equipped base.



Photograph: Scott Quintard

Standing tool cabinet

John Boldt of San Antonio built this cabinet to house his hand tools plus some that belonged to his father and grandfather. He used ten different hardwoods to create the cabinet and the custom-fitted holders within. One surprise: This cabinet rolls on heavy-duty casters.



Photograph: Michael Connally

Traditional tool chest

Paul Ganther of Stephenville, Texas, designed and built this chest to hold a treasure trove of hand tools inherited from his grandfathers. The chest resembles ones that carpenters once used to house their tools and showcase their craft. Paul's features six removable boxes (known as tills) that hold smaller items, plus large-tool storage below. There's even a recessed compartment in the lid. All are covered with veneers and inlays.



Photograph: Andy Rash

Save up to \$60 on the **BELL+HOWELL** Sunlight Lamp!

Enjoy sunshine every day of the year—indoors!

**CLEARER, BRIGHTER,
EASY ON THE EYES
NATURAL LIGHT
FOR READING, WORK,
AND HOBBIES**

- **COLORS LOOK MORE VIVID AND TRUE TO LIFE**
- **SHARP VISIBILITY FOR DETAILS**
- **BETTER CONTRAST FOR READING**
- **HELPS REDUCE EYESTRAIN**

So much like sunshine it feels like you're on vacation!

The Bell & Howell Sunlight Lamp could be the most important advance in lamps since the invention of the light bulb! It simulates outdoor sunlight, which is balanced across the entire spectrum of color visible to the human eye.

Everything seems easier to see

This is the clearest, whitest, and brightest lamp we have found. Colors look more vivid and true to life. Black and white contrast is improved, and details can be easier to distinguish.

Helps reduce glare-related eyestrain

Soft and pure white light spreads evenly across your personal space. So you see more comfortably for reading, working, and all close up tasks and hobbies. There is virtually no glare, making this the perfect companion light for computer work.

Save \$\$\$ on your electric bills!

The supplied high-tech 27-watt bulb gives as much light as an ordinary 150-watt bulb, but uses far less energy. The bulb can last up to 5000 hours - 5 times longer than other bulbs—for years of normal use.

We've nicknamed our Sunlight Lamp the "It's great to be alive lamp!"

Many people say that dreary, dark days make them feel "blue" and that bright sunny days have a cheerful and energizing effect. Now you can switch on the sunlight indoors every day of the year!



**Table Lamp
Only \$49.95**

A word about this unheard of price

This lamp features the state-of-the-art performance you expect from the well-respected Bell & Howell name. We have a special arrangement to offer it to you at an unbelievably low price. Orders will be filled on a first come, first served basis.

Get your floor lamp home for just \$17.49!

If you choose the 4-payment plan, we will ship you the floor lamp with your first payment of \$17.49 plus shipping and handling. After that we'll bill you \$17.49 once a month for three additional payments. **3 year warranty.**

NOT AVAILABLE IN STORES

Call toll-free TODAY to order your Bell & Howell Sunlight Floor Lamp while supplies last!
Floor Lamp (60.5" high): \$69.95 plus S&H
Table Lamp (26" high): \$49.95 plus S&H
For fastest service call toll-free

1-888-242-9243

24 hours a day, 7 days a week / We accept checks by phone!

WAS ~~\$99⁹⁵~~
NOW ONLY
\$69⁹⁵ EA



With ordinary lamp

BELL+HOWELL

**Bell & Howell Sunlight Lamp, Dept. 3021
P.O. Box 5555 Thousand Oaks, CA 91359
To order by mail please call toll free
1-888-242-9243 for details.**

brush on a flawless varnish finish

Most of us brush on oil-based varnish or polyurethane to beautify and protect our projects. (For the purposes of this article, we refer to oil-based varnish and oil-based polyurethane as varnish.) However, we also know the frustration of seeing dust nibs, brush marks, and runs in those finishes. Rather than accept these flaws as part of finishing with varnish, adopt the following tips. They'll pay off with a finish that feels smooth and looks terrific—guaranteed!



Seeking the key to silky-smooth results? Just follow these guidelines.

1 Before you begin ...

In most circumstances, varnish dries slowly, providing a wet, sticky gathering place for dust. When the weather turns cold, drying time really stretches out, so warm your finishing area to 70 degrees F prior to finishing.

Reduce the amount of dust in the air by making your finishing area as clean as possible. Work in a room that's separate from your workshop, if possible. Clean the floor with a wet mop, place paper under your project, and then clean the project with a shop vacuum and a store-bought tack rag or a cloth moistened with mineral spirits or naphtha. (Wear appropriate gloves when handling solvents, and ensure the space is well ventilated.)

Choose a high-quality brush with natural bristles and flagged (split) ends. Flagging increases the number of contact points, resulting in a smoother application. The bristle end of the brush should have a V shape when viewed from the side.

Make sure you can see exactly what you're doing. Place a light source nearby, at a low angle to the surface, as shown at *right*.

Build your finish with two or three coats of glossy varnish. For the final coat, apply a varnish with the desired sheen, whether satin or glossy. By following this procedure, you avoid the cloudiness produced by several layers of satin varnish.



It's easy to miss a spot or overlook a flaw as you brush on finish under typical workshop lighting. Correct the situation by placing a lamp or worklight to bounce light across the project toward you. Reflecting light illuminates glare from wet finish and highlights runs, dust nibs, and other boo-boos.

2 As you brush ...

To keep your finishing material as clean as possible, pour a small amount of varnish from the can into a jar that's wide enough for your brush. For the first coat, add an equal amount of mineral spirits (paint thinner). This mixture produces a thin coat that dries harder than unthinned varnish, making it easier to sand away the first-coat roughness without clogging the sandpaper.

The second and third coats can be slightly thinned or applied full strength.

However, when the temperature is 90 degrees or higher, fast drying becomes a problem. As a result, air bubbles solidify instead of popping, leaving bumps in the finish. Use a mix of 20 percent mineral spirits and 80 percent varnish for each coat to slow the drying and let the bubbles pop.

Now, brush on the varnish as shown in the sequence of photos *opposite, top*. After each coat dries, sand lightly with 320-grit sandpaper to remove nibs and level the

surface. If you don't see significant flaws, rub with 0000 steel wool to improve bonding of the next coat. (Substitute a synthetic pad if finishing with water-base.) Moisten a cloth with mineral spirits or naphtha and wipe the surface to remove the residue.

Apply three or more coats to a tabletop or any surface that will get lots of hard use. Other surfaces need only two coats, and intricately detailed areas look best with just two coats of a 50/50 mix.

3 secrets to beautifully brushed varnish

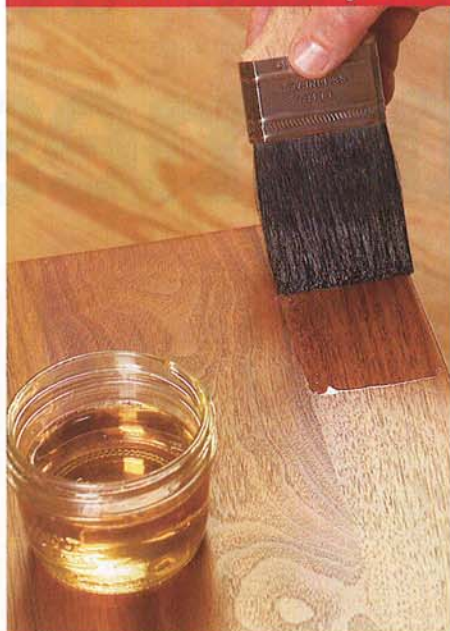

On a tabletop or other flat horizontal surface, brush varnish from one end to the other in overlapping strips. Begin each strip about 3" from one end, as shown above, and brush to that end. Then return to the starting point and brush to the opposite end.

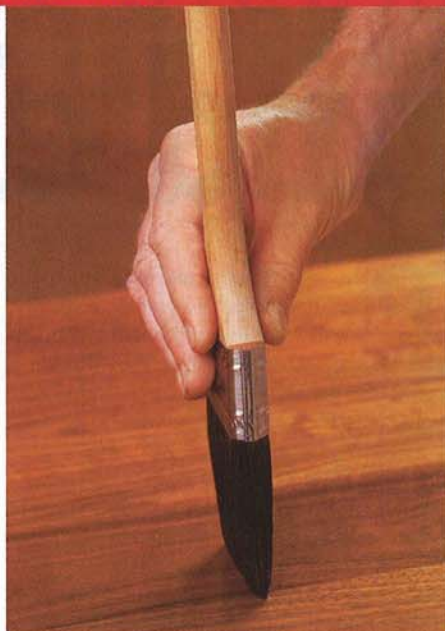

Eliminate ridges and bubbles by tipping off. First, press the bristles against the jar edge, or squeeze them with a paper towel to remove most of the varnish. Then hold the brush straight up and draw the bristle tips lightly over the wet surface with the grain.



If you can't reposition a vertical surface to lie flat, use cross-brushing to minimize runs. Load less varnish into the brush, start at the bottom and work up, brushing horizontally toward each edge from the middle. Tip off with vertical strokes from bottom to top.

3 After the finish cures . . .

For a professional-quality finish, take another step after applying the final coat of varnish. Allow the varnish to cure in normal conditions for at least two weeks, and then rub it out as demonstrated in the sequence of photos below.

Rubbing eliminates any remaining flaws, creates an even sheen, and makes it possible to adjust the sheen of either satin or glossy varnish from flat to satin to somewhat glossy—it's difficult to rub most varnish finishes to a high gloss.

Do a thorough job of rubbing on tabletops and other flat horizontal surfaces that are highly visible and often touched. The other areas of your project, such as legs, require only careful sanding or modest rubbing with 0000 steel wool. 🌲

3 steps to a professional-looking rubbed finish

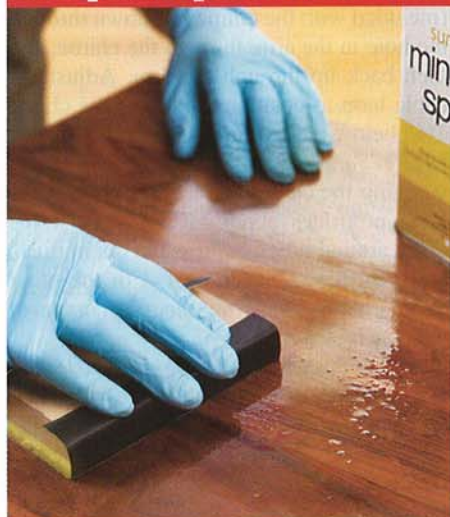

After the final coat cures, sand again as you did between coats, using 320-grit steatered sandpaper alone or 320-grit wet/dry sandpaper plus mineral spirits as a lubricant. Sand just enough to level the imperfections and wipe off the residue with a cloth.



After sanding, use 0000 steel wool to create a soft satin sheen. Press a thick piece of steel wool flat with your hand and rub firmly in long, straight strokes with the grain. Wipe off the residue on the workpiece with a cloth dampened with mineral spirits or naphtha.



For a higher sheen, rub in a fine rubbing compound, such as those found at an auto-supply store. The lamb's wool applicator shown here lets you use two hands and apply even pressure. Pick one up at a home center or hardware store.

music in the air wind chimes



Pleasing to the eye and soothing to the ear, this project assembles so easily, you'll want to build one for yourself and several more as gifts. We provide a source for the chime kit, and even show how you can make your own dowels.

Form the body

1 For the body (A), cut a 7½"-long piece of 1"-diameter dowel of a weather-resistant species, such as cedar, cypress (shown), mahogany, redwood, walnut, or white oak. (Can't find dowels in these species? Check out the sidebar, *opposite*.) Drill a centered ⅝" hole ¾" deep in each end of the dowel.

2 Make a V-block at least 7½" long out of ¾"-thick material, and draw a template alignment line along the length of the dowel, as shown in the photo, *right*. Then make a copy of the hole drilling template in the *WOOD Patterns*® insert, and cut it along the lines. Now apply spray adhesive to the template and spiral it around the dowel, where shown on **Drawing 1**.

3 Chuck a ⅜" Forstner or brad-point bit in your drill press, and adjust the fence to center the V-block underneath the bit. Place the dowel in the block, and drill ½"-deep holes at each of the nine template locations.

4 Install a 90° V-groove bit in your table-mounted router, and adjust the fence ½" away from its center. Clamp a stopblock to the fence, where shown on **Drawing 2**, and chamfer both ends of the dowel. Then move the stopblock, and rout V-grooves, where dimensioned. Finish-sand the dowel.

Add the arms and finish

1 Cut nine pieces of ⅜" dowel 3" long of the same species as the body (A) for the arms (B). (To make the ⅜" dowel, see the sidebar, *opposite*.) Using the V-block to center the arms under the bit, drill a ⅛" hole located ¾" from the end in four arms, and ¼" from the end in five arms, where shown on **Drawing 3**.

Note: For a very hard wood, such as white oak, drill ⅝" holes.

2 Sand ⅛" chamfers on one end of each dowel, and then finish-sand them. Glue the arms in the holes in the body. Make sure the dowels with the ⅛" holes located ¾" from the end go in the upper four holes, and

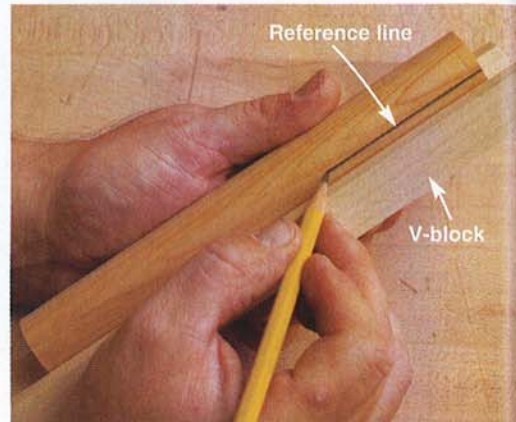

Holding the dowel in a V-block, guide your pencil along its edge to draw a template reference line on the dowel.

those with ⅛" holes located ¼" from the end go in the lower five holes.

3 With the glue dry, install ⅝" screw eyes, where shown on **Drawing 3**. Then apply several coats of an exterior oil finish. (We chose Watco Exterior Wood Finish.)

String up the chimes

1 Hang the body assembly at a convenient working height. Starting with the longest chime and the topmost arm (B), thread the end of the stainless-steel cable (included with the chime kit) down through the hole in the arm, through the chime, and then back up through the arm. Adjust the cable loop to position the top of the chime 1½" below the bottom of the body. Press a #18×⅜" brass escutcheon pin into the hole, wedging the cable in place. Stop when the head protrudes about ⅛", and twist the cable around it twice. Press the pin in flush, and trim the cable. Repeat with the other eight chimes, hanging them in order of decreasing length.

2 Slide the windbattler grommet over the cable attached to the wind catcher, where shown on **Drawing 4**, resting it on the small ferrule already crimped in place. Add the clapper. Then thread the cable through a large ferrule, through the lower screw eye, and then back through the ferrule. Adjust the length of the cable so the clapper hangs about 6" below the body (A), and crimp the ferrule with pliers. Hang the chimes, and relax to their soothing melody. 🌿

1 TEMPLATE PLACEMENT

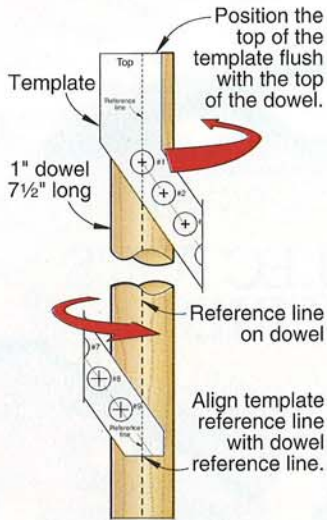

2 CHAMFERING THE BODY

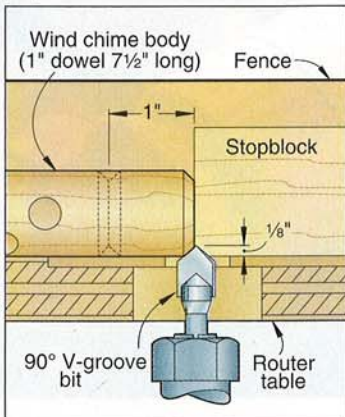

Written by **Jan Svec**
Project design: **Jeff Mertz**
Illustrations: **Roxanne LeMoine**

3 EXPLODED VIEW

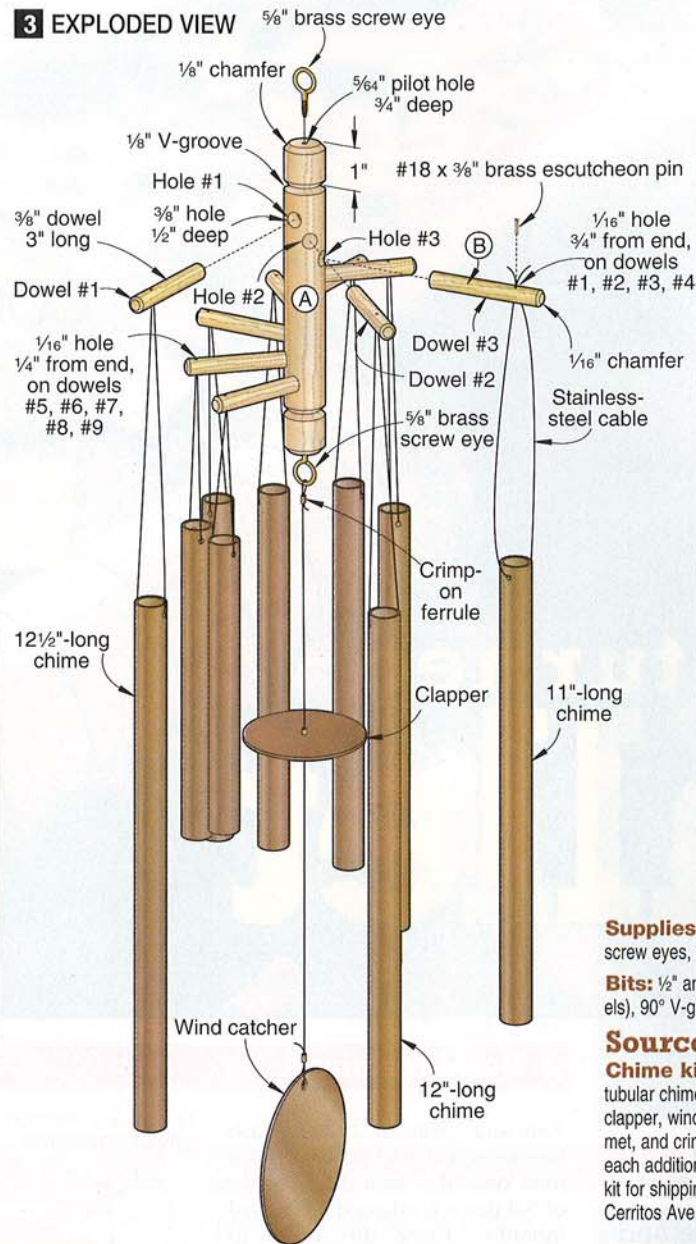

4 ASSEMBLY DETAIL

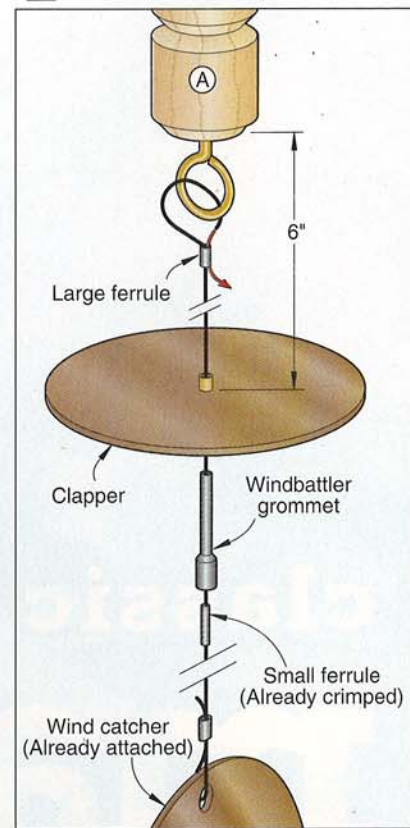

Supplies: 1" dowel, 3/8" dowel, spray adhesive, 5/8" brass screw eyes, #18x3/8" brass escutcheon pins.

Bits: 1/2" and 3/8" round-over router bits (for making dowels), 90° V-groove router bit, 3/8" Forstner or brad-point bit.

Source

Chime kit. Set of nine 3/4"-diameter powder-coated tubular chimes, 10' of three-strand stainless steel cable, clapper, wind catcher with attached cable, windbattler grommet, and crimp-on ferrule. Kit no. KWT, \$25. Add \$20 for each additional kit. Shipping via UPS included, add \$5 per kit for shipping via USPS. Jacobs Musical Chimes, 3782 Cerritos Ave., Los Alamitos, CA 90720. Call 800/627-5840.

Make your own dowels on a router table

Often when building a project, you'll need just a few short lengths of dowel, or a dowel of a species that isn't commercially available. The first case hardly justifies a special trip to the hardware store, and the second leaves you high and dry. Don't worry. With wood scraps, round-over bits, and a table-mounted router, you can make your own. Here's how.

Cut stock 3" longer than the dowel length needed, plus 6" for a test piece. (If the length-plus-3" dimension is more than one-half the length of your router-table fence, clamp on a longer auxiliary fence.) Joint and plane the stock into a square the same dimension as the diameter of the dowel needed. Cut off the 6" test piece.

Install in the router a round-over bit whose radius is one-half the diameter of the intended dowel. (For the 1" and 3/8" dowels needed in this project, use 1/2" and 3/16" round-over bits.) Position the bit with the pilot bearing flush with the fence and the bottom of the radius flush with the table. Rout 1" in on each edge of the test piece, and check its fit in a hole of the desired diameter drilled in scrap. Adjust your setup as needed.

Stick masking tape on the table, and draw a start line 1" to the left and a stop line 1" to the right of the bit center. Now with the left end of the stock at the start line, and the right end against the fence, use a pushstick to plunge the stock into the router bit, as shown at *right*. Feed the

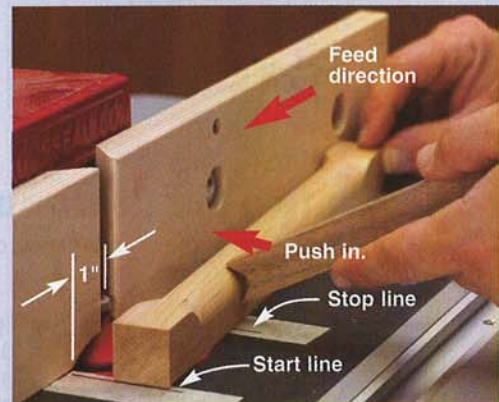

stock past the bit until the trailing end reaches the stop line. Then pivot the trailing end away from the bit. Repeat on the other three edges. Cut the dowel to length, trimming both ends.

WOOD MAGAZINE
COLLECTOR'S
SERIES
HAND TOOLS

classic turned mallet

After a simple glue-up and a quick turn between centers, you'll have one strikingly beautiful tool in no time. And with its supple ash handle and super-dense morado (Bolivian rosewood) head, you can expect a lifetime of service.

1 Build the blank

Joint and plane a 2×2×12" ash turning square to 1½×1½". Then joint one edge of a 3×30" piece of 5/4 dense hardwood. (We used morado.) Plane this piece to 7/8" thick, rip it to 2½" wide, and cut it into four 7" lengths. Glue and clamp the four pieces to the ash, in the configuration shown at *right*.

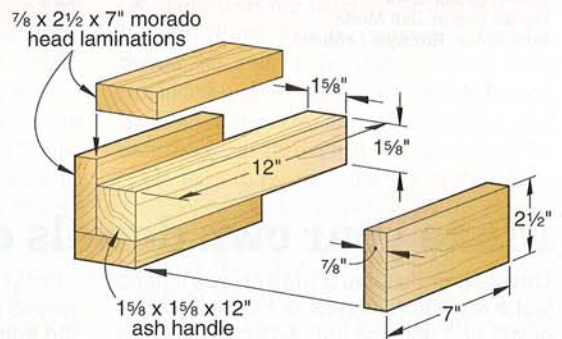

How to glue resinous woods

Gluing resinous woods, such as bubinga, cocobolo, teak, and the morado used for the mallet head, poses a dilemma. Due to their oily surfaces should you use regular woodworking glue or epoxy?

As it turns out, both suit the need. Although epoxy is foolproof and fills gaps, it's messy and more expensive. We chose Tightbond II for our mallet. With the glue surfaces of the four morado blocks jointed and planed, we wiped them with a clean rag and lacquer thinner. Then we immediately sanded their surfaces with 80-grit sandpaper, taking care not to round the edges, and glued and clamped the assembly, as shown, *above right*. After letting the glue dry overnight, we turned the mallet. We subjected it to five days of smacking chisels while cutting dovetails, mortises, and other joints at a woodworking class, followed by six months of routine shop use. The glue joints show no sign of failing.

See more
WOOD magazine
collector's series
hand tools at
woodmagazine.com/handtools



5 Form the profiles

- **Tool:** Spindle gouge
- **Tool rest:** Just below centerline
- **Speed:** 1,200–1,600 rpm

- **Tool:** Roundnose scraper
- **Tool rest:** Just below centerline
- **Speed:** 800–1,200 rpm

- **Tool:** Skew chisel
- **Tool rest:** Just above centerline
- **Speed:** 800–1,200 rpm

Using a $\frac{3}{8}$ " spindle gouge, shape the head and then the handle. On each part of the mallet, work downhill from the larger diameters to the smaller ones. At the stairstep transition from head to handle, use a $\frac{1}{2}$ " roundnose scraper to form the cove, as shown at *right*. Make light cuts to avoid tear-out. Widen the $\frac{1}{2}$ "-diameter gauging cut at the end of the handle for more working room, and use a $\frac{3}{4}$ " skew chisel to form the bead.

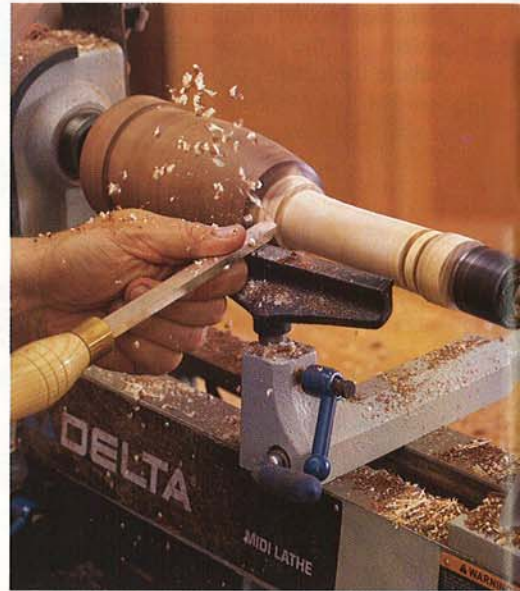
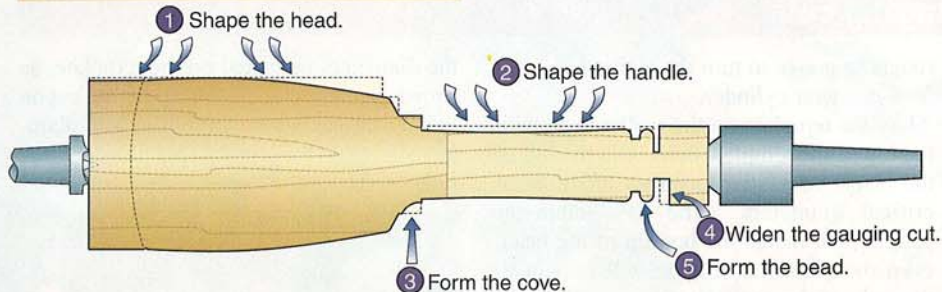

6 Sand, burn, and finish

- **Tool:** Skew chisel
- **Tool rest:** Just above centerline
- **Speed:** 800–1,200 rpm

- **Tool:** Parting tool
- **Tool rest:** At centerline
- **Speed:** 800–1,200 rpm

- **Tool:** Spindle gouge
- **Tool rest:** Just below centerline
- **Speed:** 1,200–1,600 rpm

hold the ends between your thumb and forefinger. Do not wrap the wire around your fingers or hand.

Remove the waste at the top of the mallet with a parting tool, leaving a $\frac{1}{2}$ "-diameter tenon connecting it to the spur center. Form

the domed top of the mallet with a $\frac{3}{8}$ " spindle gouge. Remove the mallet from your lathe, and trim away the waste with a fine-tooth handsaw. Finish-sand the ends with a random-orbit sander, and apply several coats of an oil finish. 🌲

Sand the finished portions of the mallet, progressing from 120-grit to 400-grit sandpaper. Using your template, mark the locations of the burn lines on the handle with a pencil. Cut $\frac{1}{32}$ "-deep grooves at each mark with the point of a $\frac{3}{4}$ " skew chisel, as shown at *near right*. Now, with the lathe running, hold a piece of 22-gauge wire or a .026" wire burner in each groove until it is singed black, as shown at *far right*. (For wire burners with wood ball handles like the one shown in the photo, see **Sources**.) Sand over the grooves with 400-grit sandpaper.

Caution: When using ordinary wire to burn the grooves, cut a piece about 8" long and

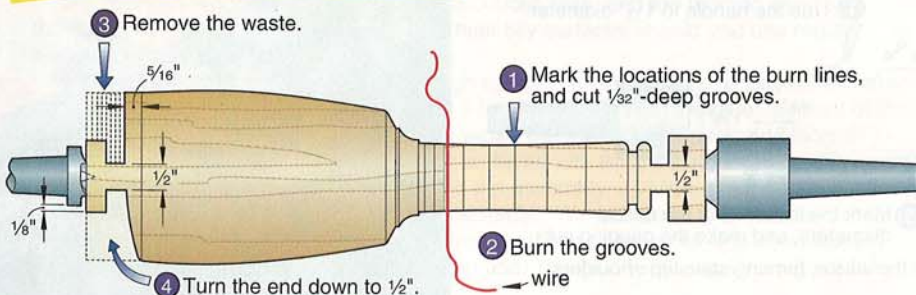
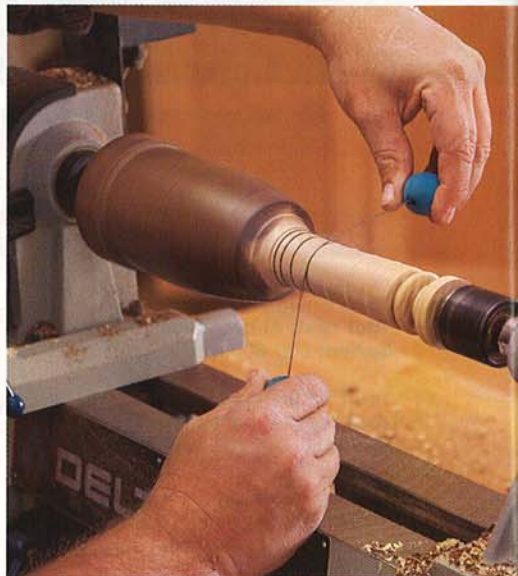

Written by **Jan Svec**
 Project design: **Jeff Mertz**
 Illustrations: **Roxanne LeMoine**

Sources

Wood kit. One $1\frac{1}{2} \times 1\frac{1}{2} \times 12$ " piece of ash and four $\frac{7}{8} \times 2\frac{1}{2} \times 7$ " pieces of morado. Kit no. W-156, \$22.95 ppd. or five kits for \$89.95 ppd. Heritage Building Specialties, 205 N. Cascade, Fergus Falls, MN 56537. Call 800/524-4184.

Wire burner. KC Spindle Wire Burners (set of three 6"-long burners, .016", .026", and .039") no. 115302, \$9.95. Packard Woodworks. Call 800/683-8876, or go to www.packardwoodworks.com.

Spirits of the Pack

Our first-ever
fine porcelain sculpture
enhanced by
dramatic artwork!



Hand-crafted figurine
becomes a unique,
fully dimensional
“canvas” featuring
Al Agnew’s
renowned art

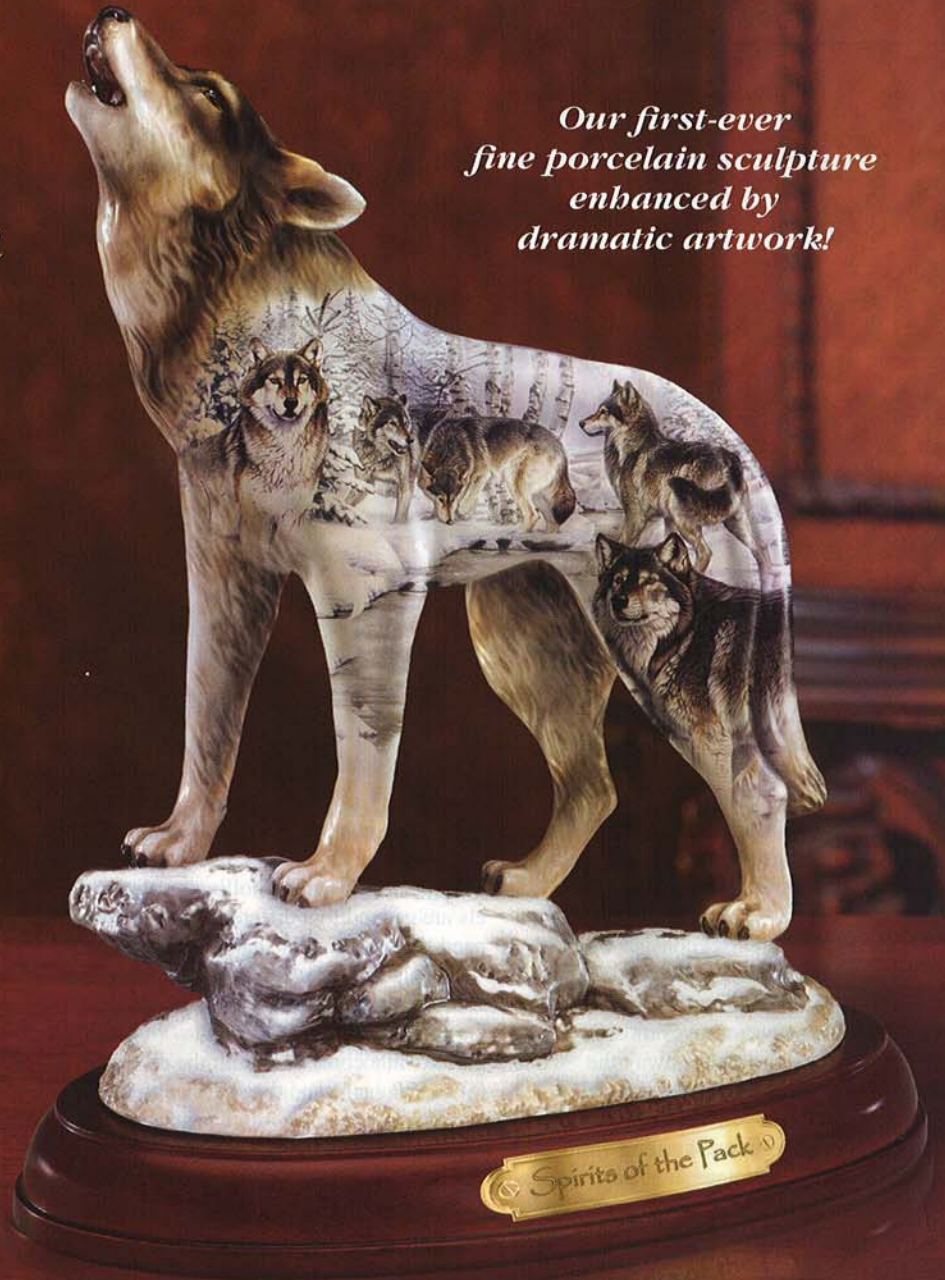

Shown smaller than appr height of
7 1/4 inches, including display base

Spirits of the Pack

Raising his voice to the silent winter sky, he calls out in a song that reaches far beyond the physical realm of the snow-filled forest, for the plaintive song of the wolf connects distant generations of the pack. In a single howl are the voices of many—the kindred spirits that reside in the heart and soul of every wolf.

Featuring the artwork of Al Agnew crafted upon a sculptural, fine porcelain wolf figure, “Spirits of the Pack” conveys the powerful, enduring presence of the wolf.

The edition is strictly limited, and demand for wolf-themed collectibles continues to be strong. To obtain this unique edition at the issue price of \$39.95 (plus a total of \$5.99 shipping and handling), payable in two installments of \$19.97 each, return the Reservation Application today.



Fine porcelain is
hand-cast and painted
for a magnificent
sculptural portrayal
of the wolf

RESERVATION APPLICATION

THE BRADFORD EXCHANGE

9345 Milwaukee Avenue · Niles, IL 60714-1393

THE *Heart* OF COLLECTING®

YES. Please reserve the “Spirits of the Pack” collectible as described in this announcement.
Please Respond Promptly

Signature _____

Mr. Mrs. Ms. _____
Name (Please Print Clearly)

Address _____

City _____

State _____ Zip _____

61920-E45691

Illinois residents add state sales tax. Prices higher in Canada. A limited-edition presentation restricted to 95 firing days. Please allow 4-8 weeks after initial payment for shipment. All sales are subject to product availability and order acceptance.

collectiblestoday.com

Home of The Bradford Exchange and All Things Collectible

©2004 BGE 01_61920-BIR

5 things you need to know about hollow mortise chisels

No matter how much you spend on a hollow-chisel mortiser—whether it's a benchtop model like those on page 78, a low-dough drill-press-mounted device, or a monstrous stationary mortising machine—you'll get the best results with the right hollow mortise chisel, properly installed and used.

A hollow mortise chisel consists of an auger bit nested inside a four-sided chisel. As you plunge this drilling duo into your workpiece, the auger removes most of the waste while the chisel pares away the corners and squares up the hole, pushing the waste into the auger, where it is ejected. After years of experience working with them in the *WOOD*® magazine shop, here's what we've learned about getting the most from these square-hole cutters.

1 Sharpen the chisel before you start; then keep it sharp. Fortunately, a couple of special accessories, shown in the photo at right, make sharpening the concave bevel inside the chisel opening virtually foolproof. Lee Valley Tools (800/871-8158, leevalley.com) sells a pair of diamond grinding stones (\$7, part no. 77J81.20) for sharpening most makes of hollow chisels. After removing the auger bit, chuck the 51° cone into your cordless drill and turn it slowly into the end of the chisel; switch to the 50° cone, and repeat to make a microbevel. This process creates a slight burr on the outside of the chisel, which we removed by lapping all four sides with 800-grit sandpaper adhered to glass. (As a bonus, this final step makes the chisel easier to pull out of the wood.)

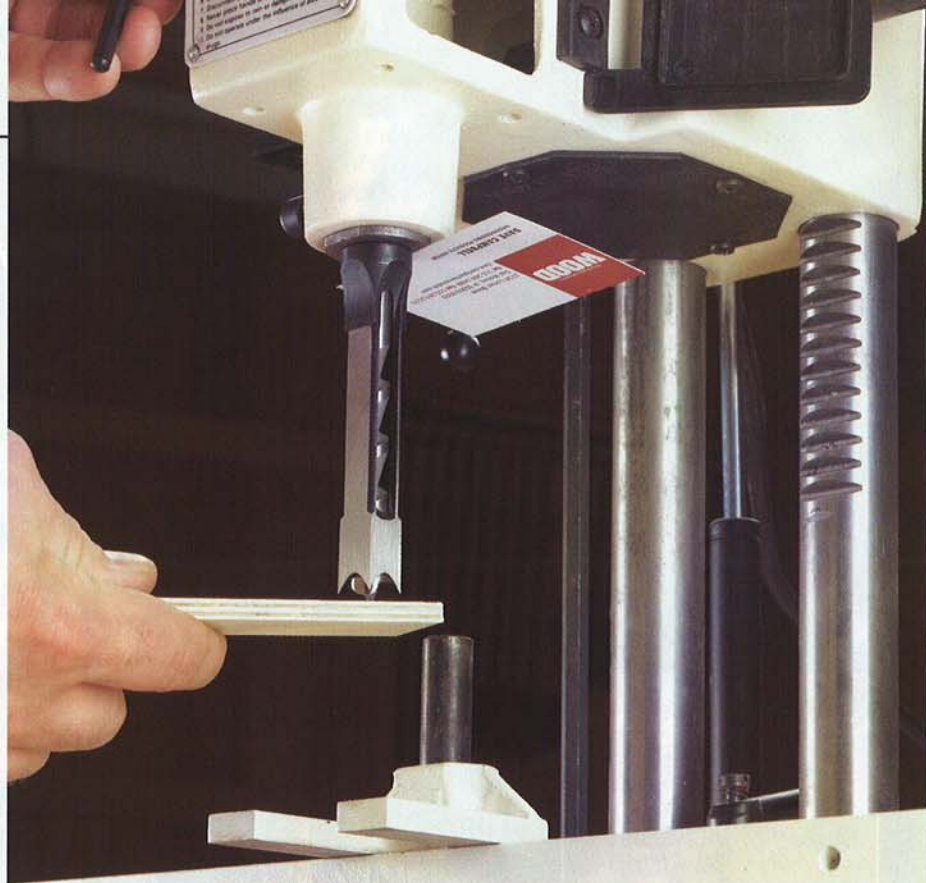

A business card between the chisel and mortiser head establishes the proper bit clearance during installation. The wood scrap protects your fingers from the chisel's sharp points.

English-made Clico hollow mortise chisels are ground to a different angle, so you'll need that company's sharpener for those. The replaceable bushing on the end of the Clico sharpener guides it into the chisel. Garrett Wade (800/221-2942, garrettwade.com) sells both the chisels (\$66–\$70 each) and the sharpener (\$89).

2 Give the bit a tiny head start. The height relationship between the auger and chisel is crucial to the set's performance. If the auger leads the chisel too much, it can stray, prematurely wearing the bit and—in extreme cases—causing the bit to break; if the bit leads too little, the chisel cuts before the bit, requiring more force to plunge into the mortise. Mortiser manufacturers recommend anywhere from 1/16" to 3/16" clearance between the bit and chisel. But in our experience, the less clearance the better, so long as the bit doesn't rub on the chisel in which it's seated.

Here's how we set up our hollow mortise chisels for minimal clearance: Mount the chisel, sandwiching a business card between it and the head of the mortiser, as shown in the photo above. Now chuck the auger bit into the mortiser, holding it snug against the bottom of the chisel. With the auger secured, loosen the chisel, remove the business card, then seat the chisel against the head and tighten it.

3 Your bits need time to chill. Heat is the enemy of any high-speed steel cutter, such as these auger bits, because overheated bits don't hold a cutting edge well. If you have a lot of mortises to cut, go grab a cup of coffee every third or fourth mortise, and

Continued on page 102

IF YOU'RE GONNA OWN 'EM, HONE 'EM



Cone-shaped grinding wheels put a sharp edge on the business end of a hollow mortise chisel held in a vise. The fluted Clico sharpener (at left in photo) works only on that brand of chisels.

Get in the zone with the mattress topper that molds to your body's contours

The Memory Foam Ultra mattress topper is cut into a grid pattern combining six different zones for variable support and a better night's sleep.

It's 3 a.m. You have exactly two hours until you have to get up for work, and you still can't seem to fall asleep. At this point, the phrase "tossing and turning" begins to take on a whole new meaning for people whose mattresses simply aren't giving proper support anymore. Your mattress may dictate your quality of sleep. Even if you merely suspect that your mattress may be outdated, that's when you need to take action. Some mattresses fail to support your spine properly, which can result in increased pressure on certain parts of your body. Other mattresses, sporting certain degrees of visco-elastic foam, can sometimes cost you well over \$1000. Now, one of the world's leading manufacturers of foam products has developed an incredibly affordable mattress topper that can actually change the way you sleep. Introducing the future of a better night's sleep: The Memory Foam Ultra mattress topper.

Sleep Better™...Wake up to a better morning. The Memory Foam Ultra mattress topper is designed to give you a better sleep surface. Not only does it support each region of your body, but it's also temperature sensitive. With its various-sized "comfort cells," the 2-inch thick Memory Foam



The 2-inch thick temperature-smart foam adjusts to your shape.

Ultra mattress topper combines six zones to support specific body area weight, which promotes a better night's sleep. The largest cells support your lower back and midsection, while the medium-sized cells support the shoulders, lower back and legs. The smallest cells support your head and feet. Combined, these zones provide variable support from head to toe. By using visco-elastic foam, the Memory Foam Ultra mattress topper also molds to your body contours to help prevent tossing and turning during the night. When you lie down on this amazing material, the heat and pressure sensitive foam reacts to your body's weight and temperature, so that it molds to your exact body shape. This means that whether you sleep on your back, stomach or side, your weight is evenly distributed and your spine remains in a neutral position. Other surfaces support your body at the shoulders, hips and legs only. This causes your spine to sag in other areas, which can often result in discomfort, and even back pain. You'll wake up rested, relaxed and ready to take on the day. Anyone who suffers from insomnia and back pain due to mattress discomfort can benefit from this technology.

up to 21 inches thick. The size of the mattress pad is determined by the size mattress topper you order.

Try it for yourself today! The Memory Foam Ultra mattress topper can change the way you sleep. Promote proper spine positioning, while enjoying relief from insomnia and back pain with this full-body support. It comes with a 5-year manufacturer's limited warranty and TechnoScout's exclusive in-home trial. If you are not completely satisfied, simply return it within 60 days for the full purchase price.

Memory Foam Ultra Mattress Topper: Item# 2P-2870

Sizes Twin through California King*

Prices starting as low as ~~3~~... *2 payments* of \$49.95 each + S&H

FREE mattress pad—a \$59.95 value!

Please mention promotional code 26669.

For fastest service, call toll-free 24 hours a day

888-923-6684



*For mail-in orders, please call for individual cost of the various sizes along with shipping and handling. To charge it to your credit card, enclose your account number and expiration date. Virginia residents only—please include 4.5% sales tax.

LATEST...GREATEST...NEATEST...COOLEST
You can see hundreds of high-tech products at www.memoryfoamtopper.com

TECHNO SCOUT®

1998 Ruffin Mill Road
Colonial Heights, VA 23834

All rights reserved. © 2004 TechnoBrands, Inc.

What could be wrong with your present bed?

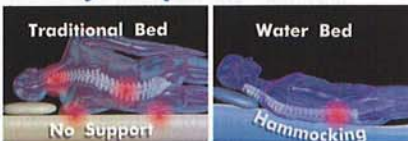

The ideal position is a neutral body posture in which the different parts of the human body are supported individually and evenly. This is the secret behind Memory Foam Ultra, the mattress topper that turns any bed into the ideal sleep surface.

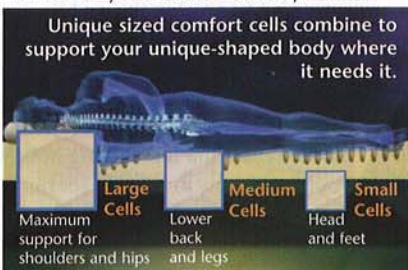

FREE heavyweight mattress pad included.

Included with the Memory Foam Ultra mattress topper is a fitted mattress pad. It's heavyweight and quilted, and made of 200-count 100% cotton with a 14-inch deep stretchable skirt to fit a mattress



Router Bits and Shaper Cutters

WOODLINE USA

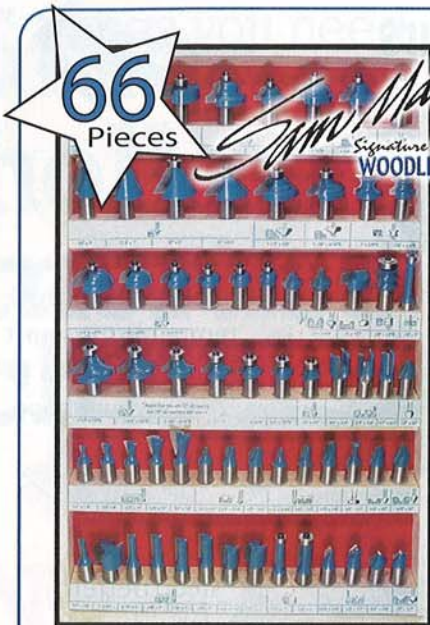

66
Pieces

Signature Series by
WOODLINE USA

Master Craftsman Woodworking Collection

Only **\$189** set

Includes Deluxe Wall-Mountable Wooden Case

- | | |
|------------------------------|-----------------------------|
| 8 Straight Bits | 1 Double Roman Ogee W/ Cove |
| 5 Dovetail Bits | 1 Plunging Roundover |
| 3 Core Box Bits | 1 Stepped Cove |
| 3 Roundnose Bits | 2 Edge Beading Bits |
| 2 Flush Trim Bits | 1 Multibeading Bit |
| 3 Mortising Bits | 1 Bowl & Tray Bit |
| 1 Plunging Panel Bit | 1 Key Hole Bit |
| 1 Laminate Trim Bit | 1 Double Roman Ogee |
| 1 Bevel Bit | 1 Classic Double Roundover |
| 3 90° V-Groove Bits | 1 Flat Bottom 60° V-Groove |
| 2 Roman Ogee Bits | 1 Standard 60° V-Groove |
| 6 Roundover Bits | 3 Rabbeting / Slot Cutters |
| 1 Point Cutting Roundover | 4 Chamfer Bits |
| 1 Ogee With Fillet | 6 Cove Bits |
| 1 Plunging Roundover W/ Bead | |

WL 2066 For 1/2" Shank

WL 2065 For 1/4" Shank

blades and bits

allow the bit to cool in between. While the bit is still warm (but not hot), dip the end in paraffin wax, which will travel up the flutes with your next cut and aid with ejection of the waste chips.

4 Take full cuts at both ends and partial cuts in between. Bore the ends of your mortise first, and then make a series of barely overlapping cuts in between to clear the remaining material, as shown in the Mortise Boring Sequence drawing, below. Removing much less than a full bite can increase side-to-side deflection and the likelihood of auger-bit breakage, especially in 1/4" chisels, so take as much waste as you can with each cut.

MORTISE BORING SEQUENCE

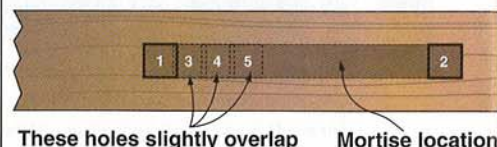

These holes slightly overlap Mortise location

We find this slight-overlap method about 50 percent faster than the common practice of taking a series of nonoverlapping cuts, and then boring out the material in between. The latter method does, however, result in virtually zero side-to-side deflection, and we'll sometimes use it for 1/4" mortises. Regardless of which method you use, when the main cutting is complete, go back and clean up the mortise with a closely spaced series of full-depth cuts.

5 Put your money where it makes the most sense. Not surprisingly, we've found that premium-priced hollow mortise chisels perform better than lower-cost ones. But, at about \$70 per chisel, you can quickly spend more on chisels than you spend for the mortising machine itself. Pay the premium if you'll make a lot of one size of mortise, or if you routinely cut 1/4" mortises. Machining mortises puts a lot of stress on smaller bits, and the less-expensive bits break more easily. (We've even seen a 1/4" auger bit unravel in the middle of a cut.)

If you make mortises only occasionally, buy an inexpensive 3/8" hollow mortise chisel for \$9-\$30. It should serve you well if you're careful to keep it sharp and not overheat the bit. Buying hollow mortise chisels in a small set further lowers your per-chisel cost.

ANNOUNCING

Your Favorite Source For Router Bits And Shaper Cutters Has Teamed Up With Americas Favorite Master Craftsman To Bring You...

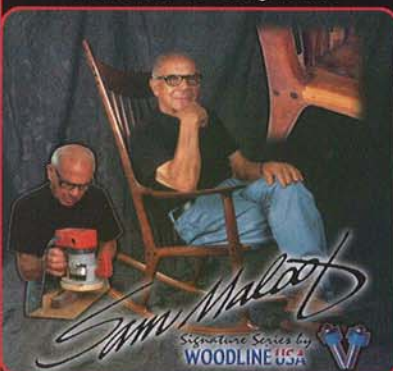

...A Premium Line Of Professional Tools From Our Workbench To Yours!

WL-2008 \$189 VALUE
OUR PRICE
ONLY **\$75** set

8 Pcs Perfect for making great looking picture frames. Bits can be combined to form complex mouldings or decorative frames.

PICTURE FRAME SET

MOULDING SET
5 Incredible Profiles
OUR PRICE ONLY **\$99** set
1/2" Shank Router Bits WL-2011 \$175 VALUE

3 Piece CABINET DOOR SET
1/2" Shank Router Bits
2-pc Roman Ogee Rail & Stile
3 1/4" Panel Raiser
WL-2019-1 \$129 VALUE
OUR PRICE ONLY **\$69** set Other Profiles Available

MOUNTED LASER CUTTING GUIDE
Quality made. Precision cutting accuracy. Economical battery operated. (included) Versatile, easily mounts to your chop saw, compound miter saw, radial arm saw, or drill press.
Quality • Precise • Economical • Versatile

LASER CUTTING GUIDE
WL LAZ \$39

6 Piece CABINET DOOR SET
1/2" Shank Router Bits
• 2-pc Rail & Stile (Roman Ogee) • Drawer Lock
• 3 1/4" D Panel Raiser (Ogee) • Door Lip • Glue Joint
WL-2020-1 \$175 VALUE
OUR PRICE ONLY **\$119** set

Router Bits and Shaper Cutters

WOODLINE USA

GREAT ROUTER BITS AND SHAPER CUTTERS
BEST SELECTION / BEST PRICE!

ORDER TOLL FREE **1-800-472-6950**
WOODLINE USA • 111 WHEELER ST • LA VERGNE, TN 37086

Visit us at our Web site: **WOODBITS.COM**
E-mail: woodline@woodbits.com

PREMIUM CARBIDE
• Euro Anti-Kickback Design
• Super-Slick Non-Stick Finish
• Super Low Prices
QUALITY Guaranteed

• INDIVIDUAL BITS ALSO AVAILABLE • ALL MAJOR CREDIT CARDS • SAME DAY SHIPPING •

New lure's catch rate may be too high for some tournaments.

Out-fishes other bait 19 to 4 in one contest.

Uses aerospace technology to mimic a real fish.

ORLANDO, FL— A small company in Connecticut has developed a new lure that mimics the motion of a real fish so realistically eight professionals couldn't tell the difference between it and a live shad when it "swam" toward them on retrieval. The design eliminates wobbling, angled swimming and other unnatural motions that problem other hard bait lures. It swims upright and appears to propel itself with its tail.



by Charlie Allen

Curiously, the company may have designed it too well. Tournament fishermen who have used it said it's possible officials will not allow it in contests where live bait is prohibited. They claim it swims more realistically than anything they have ever seen. If so, that would hurt the company's promotional efforts. Winning tournaments is an important part of marketing a new lure.

Fish would probably prefer to see it restricted. I watched eight veteran fishermen test the new lure (called The KickTail™) on a lake outside Orlando FL for about four hours. Four used the KickTail and four used a combination of their favorite lures and shiners (live bait). The four using the KickTail caught 41 fish versus 14 for the other four. In one boat the KickTail won 19 to 4. The KickTail also caught bigger fish, which suggests it triggers larger, less aggressive fish to strike. You can see why the company needs to get it into tournaments. An almost 3 to 1

advantage can mean thousands of dollars to a fisherman, and hundreds of thousands in sales to the company.

The KickTail's magic comes from a patented technology that breaks the tail into five segments. As water rushes by on retrieval, a little-known principle called aeronautical flutter causes the tail to wag left and right, as if the lure were propelling itself with its tail. Unlike other hard baits, the head remains stationary—only the tail

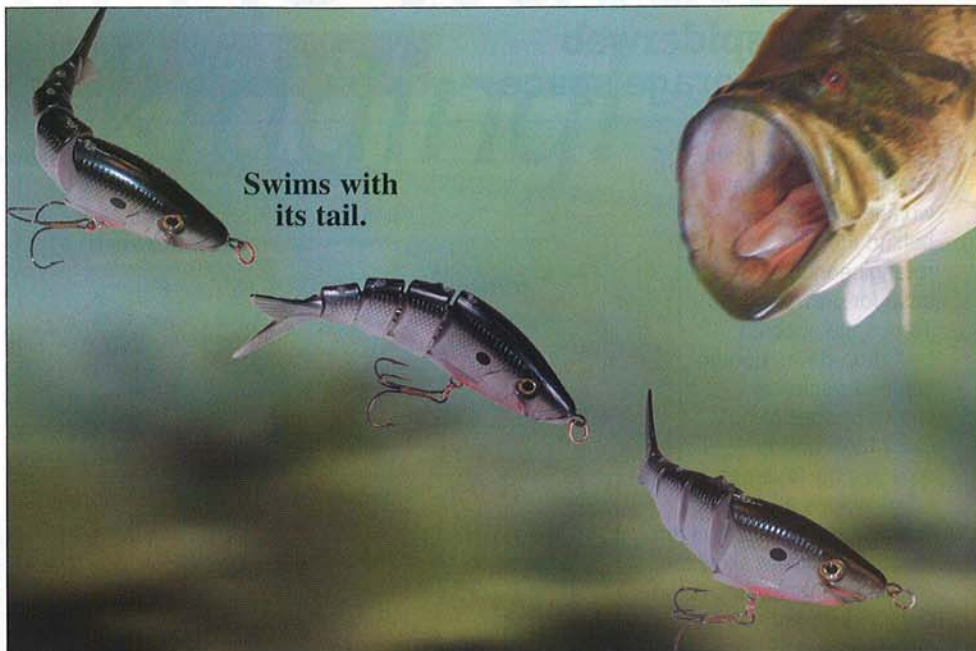

New lure swims like a real fish--nearly triples catch in Florida contest.

wags. A company spokesman told me this.

"Fish attack live things, and they determine if something is alive by watching its movements. Marine biologists will tell you that the more a lure swims like a real fish, the more fish it will catch. Well, the only live thing the KickTail doesn't do is breathe. It's better than live bait! It lasts longer and it never hangs half-dead from a hook. It's always swimming wild and free. Fish can't stand it. We've seen fish that have just eaten go for the KickTail. It's like having another potato chip.

Increases catch almost 3 to 1.

"To make the KickTail even more lifelike, we gave it a natural shad color and shaped it like the most prevalent bait fish of all, the threadfin. Game fish gobble up more threadfin shad than any other baitfish.

"We knew the KickTail would out-fish other lures. It had to. Other lures wobble their heads and swim on an angle. But 41 fish to 14? That's huge! I tell you, in ten seconds anyone who has fished a day in his life knows this little swimmer's a home run. Fishermen reserved thousands of KickTails before we produced it! Here, reel it in and watch it swim toward you. Can you tell the difference between it and a live fish? (I said no.) Neither can the fish.

"The flutter technology also allows the

KickTail to swim at the water's surface. Other top water lures must be worked to have any live action, or have a bill that makes them dive on retrieval. Our diver version is the only deep crank bait that let's you do tricks like 'walk the dog.' Twitch it at deep levels and it gives an irresistible, lifelike action. Other lures 'dig.' And there's no need for rattles. The five tail segments click together as you pull it through the water, calling fish from a distance."

Whether you fish for fun or profit, if you want a near 3 to 1 advantage, I would order now before the KickTail becomes known. The company even guarantees a refund, if you don't catch more fish and return the lures within 30 days. There are three versions: a floater for top water, a diver and a "dying shad" with a weed guard for fishing lily pads and other feeding spots. The company says it's the only hard bait of its kind in existence. Each lure costs \$9.95 and you must order at least two. There is also a "Super 10-Pack" with additional colors for only \$79.95, a savings of almost \$20.00. S/h is only \$6.00 no matter how many you order.

To order call **1-800-873-4415** or click www.ngcsports.com anytime or day or send a check or M.O. (or cc number and exp. date) to NGC Sports (Dept. **KT-735**), 60 Church Street, Yalesville, CT 06492. CT add sales tax. The KickTail is four inches long and works in salt and fresh water.



Inventor Scott Wilson lands a 10-pounder.

shop tips

Helping you work faster, smarter, and safer

Our Winner

Convert spiderweb place to storage space

top shop tip

I discovered a simple way to make use of the space underneath my workbench top and behind the skirt without re-engineering the base for drawer boxes. To use the space, I built drop-down storage compartments, as shown at *right*, to hold small tools and to organize my fasteners.

The hinges attached between the back apron and the plywood base allow the compartments to drop down. Chains, secured to the benchtop and the box sides with screw eyes, limit the depth of the drop. A locking hasp firmly secures the storage units out of the way.

—Dan Opper,
Lawrence, Kan.

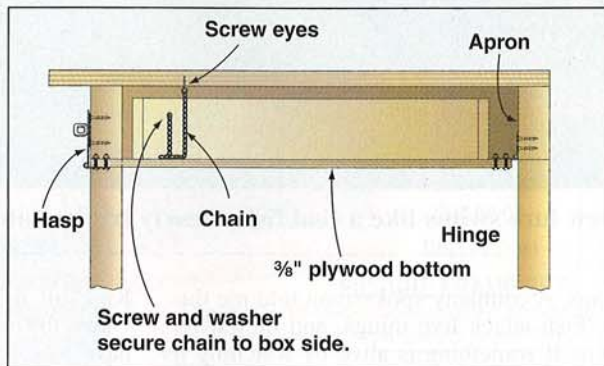
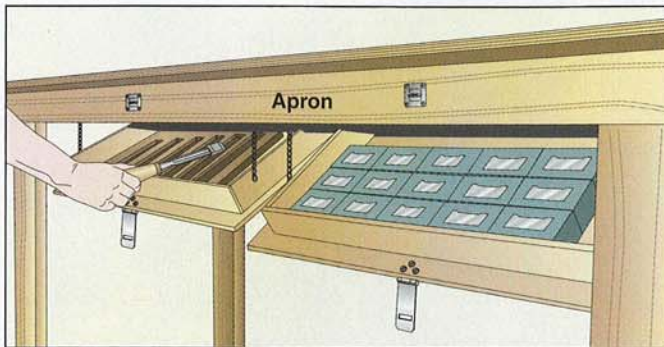

Like most of us—regardless of the size of our shops—Dan Opper wanted to squeeze every bit of storage from his space. “One day, I was looking at my bench,” says the retired telephone engineer, “and I thought, there’s wasted space under this benchtop. What can I do with it?” After a little pondering, Dan came up with the idea at *left*, and we think it’s a dandy. We named it our Top Shop Tip for this issue.



Dan will have to clear more room in his shop for the Makita LS1220 12" miter saw we're sending his way.

How to ground flying reindeer

I made several of *WOOD*® magazine's reindeer lawn ornaments but had trouble with them trying to take flight and join Santa's sleigh whenever a strong wind blew. To put a stop to their aerial ambitions, I anchored 5' lengths of 3/4" rigid electrical conduit to their hooves.

For each outdoor ornament, buy one 10' length of conduit and cut it in half. (Spray-paint the pipe if you want it to blend into the surface it's sitting on.) Next, drill small holes through your reindeer's hooves and secure the conduit with plastic cable ties or wire. These pipes will keep your reindeer firmly grounded in even the strongest winds and the method is much easier than driving stakes into frozen ground.

—Richard Hedges, Woodstock, Ill.

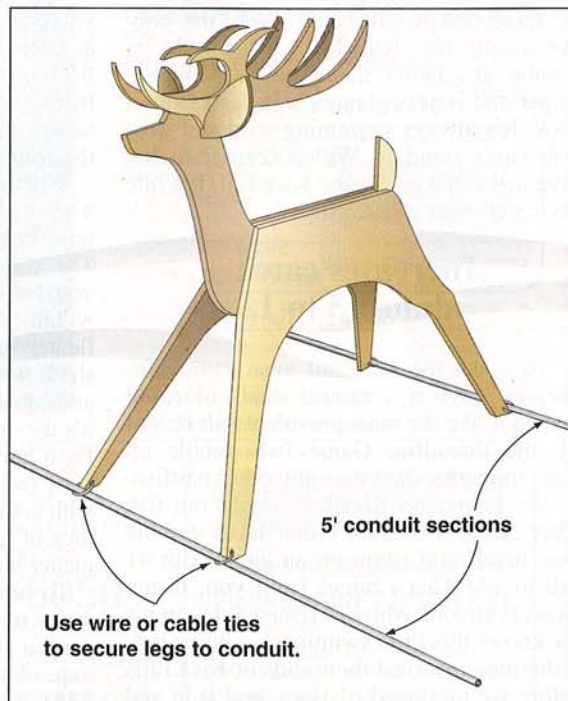

Continued on page 106

Top tips win tools!

Describe how you've solved a workshop dilemma, and you'll get \$75 if it appears here. And, if your tip earns Top Shop Tip honors, you'll also win a tool prize worth at least \$250.

Send your best tips, along with photos or illustrations and your daytime telephone number, to: **Shop Tips, WOOD Magazine, 1716 Locust St., GA-310, Des Moines, IA 50309-3023.** Or e-mail tips to: **shoptips@woodmagazine.com.** Remember to include your contact info in the e-mail as well.

Because we try to publish only original tips, please send your tips only to *WOOD* magazine. Sorry, but submitted materials can't be returned.

No springs. No air. No water. No kidding!



No better bed than Tempur-Pedic.

Our Weightless Sleep bed embodies an *entirely new* sleep technology. It's recognized by NASA. And widely acclaimed by the media. It's the *only* one recommended worldwide by more than 25,000 medical professionals. Moreover, our high-tech bed is preferred by countless stars and celebrities, people who demand the best.

Our scientists invented an amazing viscoelastic sleep surface: TEMPUR® pressure-relieving material. It *reacts* to bodyshape, bodyweight, *bodyheat*. Nothing mechanical or electrical. Yet, it molds precisely to your every curve and angle.

Tempur-Pedic brings you a relaxing, energizing quality of sleep you've never experienced before. That's why 91% of our enthusiastic owners recommend us to friends and family.

Please call us toll-free, without the slightest obligation, for a FREE DEMONSTRATION KIT!



THE *ONLY* MATTRESS RECOGNIZED BY NASA AND CERTIFIED BY THE SPACE FOUNDATION ♦

Free Sample/Free Video/Free Info
FREE IN-HOME TRYOUT CERTIFICATE



YOURS FOR THE ASKING!

800-645-4047

Call toll-free or fax 866-795-9367



Contain the shower of lathe shavings with a curtain

Turning wood in my small shop presented me with a few problems. I was forever wiping wood shavings off my shelves, nearby bench tools, and out of nail bins. Also, because I turn green or semi-green wood, my other tools ended up getting a rust-making shower from the wet shavings.

My solution was to hang shower curtains from the ceiling joists and around the lathe. I screwed J-hooks into the bottom of the ceiling joists to hold the curtain rods and to make it easy to take down my little tent. The curtains contain the water spatter and force the shavings to drop to the floor, making cleanup easier and protecting my other tools.

—Kip Stratton, Otego, N.Y.



DRIVES 4 SIZES OF NAILS WITH NO EFFORT

■ Comfortable Ergonomic Styling with Cushioned Non-Slip Grip.

■ Trigger and Surface Safety Locks.

■ Non-Marring Bumper.



DRIVES 4 DIFFERENT SIZE BRAD NAILS UP TO 1 1/4" LONG

14 AMP SURGE POWER

■ New Heavy Duty Nail Driving Power with Built-in 10' Cord.



Available at home centers, lumber yards and hardware stores, wherever fine tools are sold.



Arrow Fastener Co., Inc., 271 Mayhill Street, Saddle Brook, New Jersey 07663
Canada: Jardel Distributors, Inc., 6505 Metropolitan Blvd. East, Montreal, Quebec H1P 1X9
United Kingdom: Arrow Fastener (U.K.) Ltd., Unit 5 ZK Park, 23 Commerce Way, Croydon CR0 4ZS, Surrey
www.arrowfastener.com Rev.1002

Effective router dust collector for just pennies

Although most of my tools have good dust collection, capturing debris from a router while making edge cuts was a big problem. To make my router dust-free, I created a dust-collection hose adapter using hose clamps and two 10" aluminum ring-shank gutter spikes.

First, I slightly bent the spikes about 3" from the end. Then I inserted them in the edge-guide holes of the router base, secured them with screws, and used the hose clamps to strap on a 4" flexible hose that connects to my dust collector. With the hose end positioned about 1" from the router bit, this setup grabs almost all the dust generated.

—Roger Schoenhals, Lake Orion, Mich.

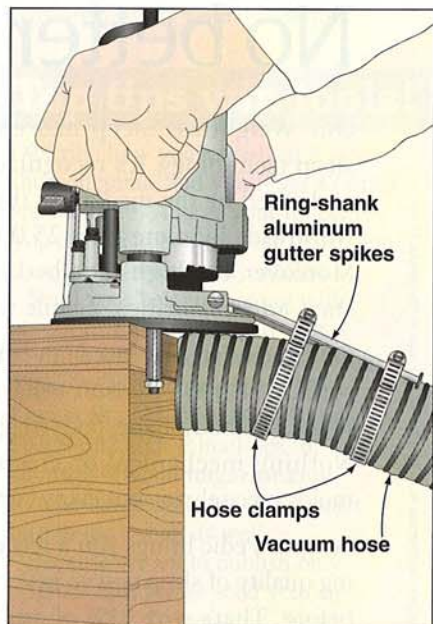

It takes a thick skin to hide your boo-boos

While building oak kitchen-cabinet doors, I jugged up my drill press to bore the 35mm hinge holes in the door stiles and started drilling away. After the second door, I suddenly realized that it matched the first door a little too well—I'd just drilled them as if they were two left doors, instead of left and right! With no extra parts, and no way to plug the holes and have the doors look right, I racked my brain until I came up with this solution.

First, from a piece of oak the same dimensions as the botched stile, I resawed a slightly over-thick patch and sanded it to exactly 1/8"-thick using my drum sander. Next, I set up my tablesaw to cut 1/8" deep, positioned the fence to cut along the rail-and-stile joint line, and made the cut. Finally, I reset the blade height to the width of the stile, and moved the fence to take 1/8" off the back of the stile, and again, made the cut, this time with the door on edge and a tall auxiliary face mounted to my fence. These steps resulted in a 1/8"-

deep rabbet in the back of the door as wide as the stile—a perfect match for the patch I made earlier.

After gluing the patch into place, I ran the door through the drum sander again to clean up the joint. With the misplaced holes now well-hidden, I again bored the hinge holes—this time in the correct side of the door!

—Ray Walton, via e-mail

CREATING A PLACE FOR THE PATCH

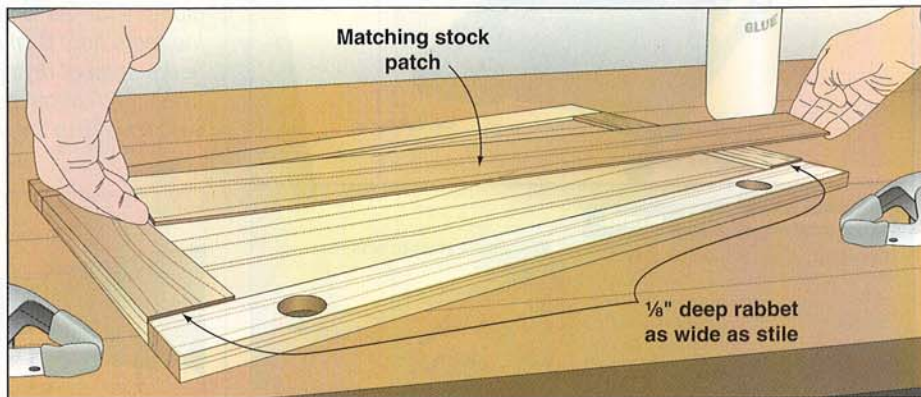
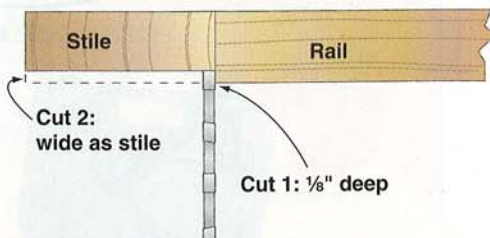

Continued on page 108

107

LAGUNA TOOLS

www.lagunatools.com

Call for **FREE Video!**
1.800.234.1976

The new Laguna TS table saw is setting a new high standard by which all others will be measured.

The X31 multi-task machine has a lineage second to none. This third-generation combination machine is a best seller, with updated fences and increased cutting capacity.

Meet our latest award-winning machine, the LT 14 bandsaw. Packed with outstanding features for powerful performance. 1.7 HP motor - 13 1/4" throat - 1/16" to 1" blade - 8" resaw.

The **BLUE** Mark of Quality.

Kreg
POCKET HOLE SYSTEMS™

Quality tools, education, service and value.

Expect this and more from **KREG**, the leader in Pocket Hole technology.

Kreg Jig® ProPack

A better way to join wood.

Faster... No waiting for the glue to dry.
Stronger... Screws put unmatched clamp pressure on the joint line.
Simpler... Drill pocket holes in only one workpiece. Align for assembly with a single clamp.
Better! Faster assembly, stronger joints, fewer headaches. Give it a try today!

Two simple steps to wood joinery...

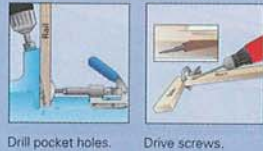

www.kregtool.com



800.447.8638

Circle No. 802



8116 Highway 123 North
Toccoa, GA 30577

www.osbornewood.com

DINING TABLE



- 1130**
Country Squire
5 x 29
- 1113**
Heritage
2½ x 29
- 1114**
Portsmouth
4 x 29
- 1122**
Old World
3½ x 29
- 1153**
Tapered Rope
5 x 29

Request our **NEW** catalog: 1-800-746-3233 • Order line: 1-800-849-8876

Circle No. 1849

shop tips

Hotmelt veneer adhesive out of a bottle

You can make your own hotmelt veneer by coating both your workpiece and a piece of veneer with a good quality woodworking glue. (I use Titebond II.) Let it dry completely, then iron it on like you would with normal hotmelt wood tape. It works amazingly well, and allows you to veneer areas larger than you can with veneer tape.

—Don West, Phoenix, Ariz.

Don, we checked out your tip with Dale Zimmerman at Franklin International (maker of Titebond woodworking glues), and he says you're right on the money. Dale told us that you can let the glue dry for "as long as a couple of days, but the longer it dries, the more heat it takes to reactivate the adhesive." He says five hours or so of drying is about right for Titebond II. Dale suggests using the "cotton" setting on your iron, and keep it moving to prevent scorching the veneer.

—WOOD® magazine

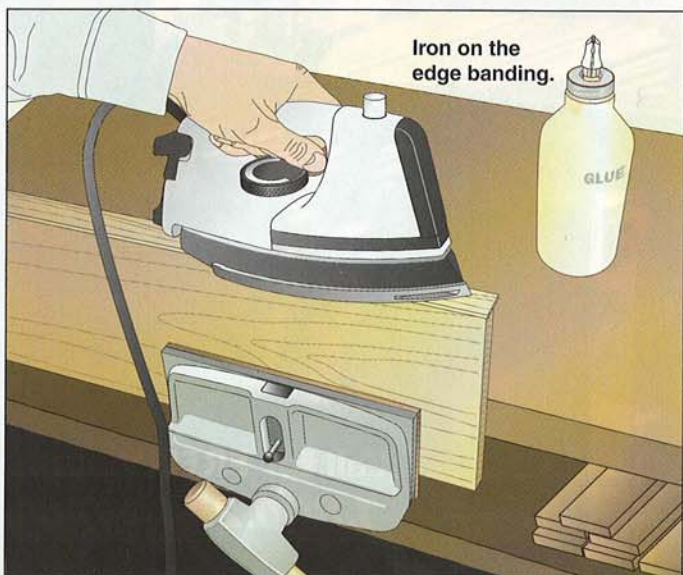
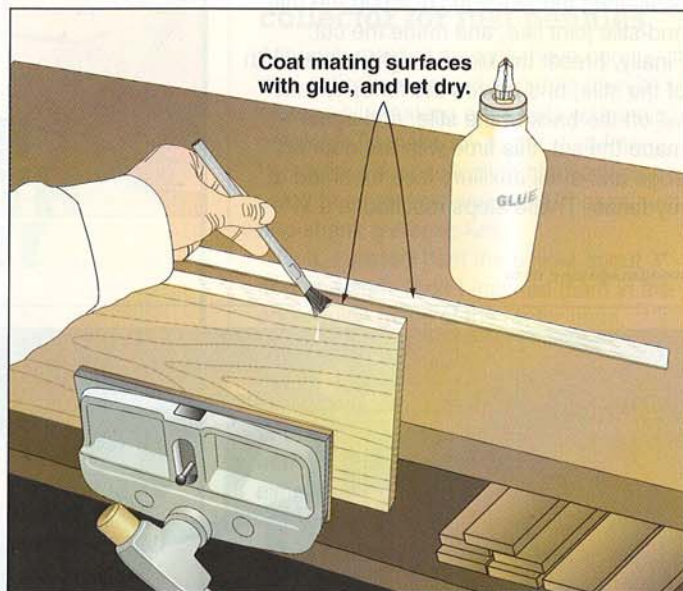

Tip your hat to this pivoting outfeed table

Having a roller stand in the shop is almost like having another person around to help you work with long and cumbersome

material, but roller stands also have a frustrating flaw: If the material is warped or droopy, you'll probably knock over the stand before you get help from it. The tilting plywood platform, shown at right, virtually eliminates this problem.

To use it with your table saw, set the level platform height to match your table saw top, and then tilt the platform toward the saw. When you feed the board through, it catches the platform and

levels it out, and the roller stand will remain standing.

—J. D. Stanley, Cleveland Heights, Ohio

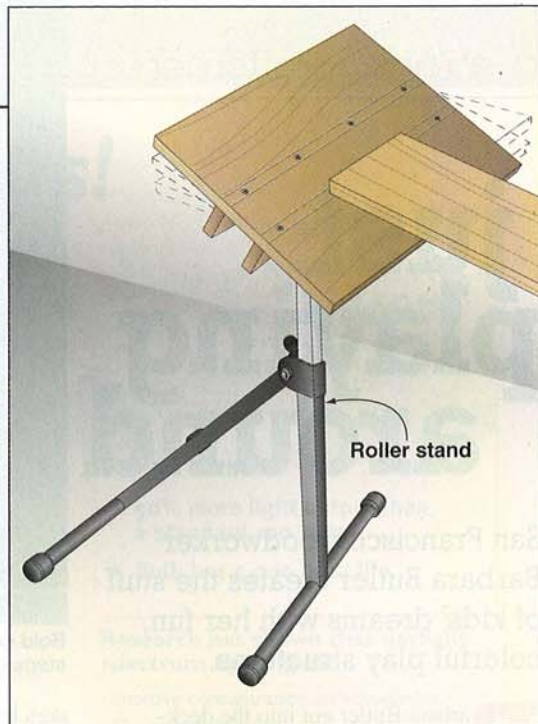
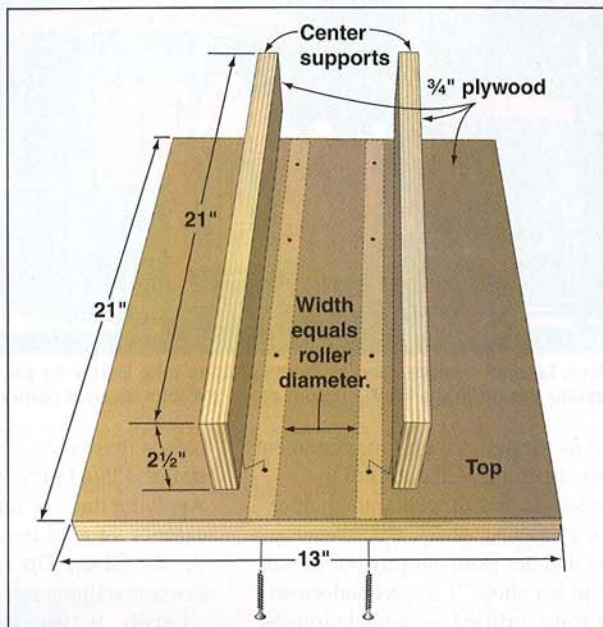

See a new

Shop Tip of the Day at
woodmagazine.com/tips



GENERAL INTERNATIONAL

IWF 2004

August 26-29, 2004
Atlanta, Georgia USA
Georgia World Congress Center
www.iwf2004.com
Booth 6063 Hall B

WWW.GENERAL.CA

ROCKLER
WOODWORKING AND HARDWARE

THE WORLD'S
BEST
SELECTION
OF HINGES

50 years
1954-2004

Call or go online to get your **FREE** catalog today! Code 14033

1-800-403-9736 -or- rockler.com/go/V4335

just playing around

San Francisco woodworker Barbara Butler creates the stuff of kids' dreams with her fun, colorful play structures.

Barbara Butler got into the deck-building business to help pay the bills during her starving-artist days. A skilled craftsperson, she also created carved furniture in vibrant colors. Before long, she combined her talents to develop unique playhouses and backyard structures that attract kids like candy.

Today, Barbara, *below*, and her crew of 10 design and build about 40 of these backyard-adventure structures per year. The themed, multi-level masterpieces fetch from \$6,000 to six-digits, and they are shipped and installed all over the country.

Creating fantasy worlds

Barbara begins the process of building a custom structure by meeting with the prospective buyer, surveying the site, and



Barbara demands quality materials and construction to create safe, lasting structures.



All photographs: Teena Albert

Bold colors, fanciful designs, and complex shapes take Barbara's play structures several steps beyond the ordinary. Each custom piece exhibits its own personality.

sketching the design. Careful measurements ensure the structures will conform to changing terrain and fit well among other landscape elements.

Barbara and her team entirely build each structure in her shop. "I use second-growth redwood from certified sustainable forests," she says. "It's beautiful, great to work with, and lasts for years without chemical preservatives." She uses jigs to simplify creating complex shapes and insists on tight tolerances and furniture-grade workmanship.

With construction complete, the parts get numbered then disassembled for staining and finishing. During this time, Barbara adds such details as cutouts and carvings.

Next, the crew rebuilds the structure to double-check workmanship, then preps it for shipping. These processes eat man hours—a playhouse may take 70 hours to build—and the attention to detail shows.

Building to last

Craftsmanship remains apparent in such details as fasteners and hardware. "I use stainless-steel screws and bolts to withstand the weather and prevent rust stains on the wood," says Barbara. All steel parts feature a tough baked-on finish that seals them against the elements and softens any sharp edges.

Good materials help the structure last, and careful finishing preserves color. Every piece receives exterior tung oil stain, usually in several of the 50 custom colors Barbara

blends (base colors come from Woodburst stains: 425/433-0899; woodburst.com). Applying three or four coats of clear exterior tung oil finish seals in the color. See the **Shop Tip** on page 112 for more exterior staining tips.

Finally, Barbara ensures the structures go together properly on site by either installing them herself, supervising, or providing written instructions to a qualified contractor.

The debate over doing more

Barbara's business keeps her pace hectic, with 80-hour weeks a norm, but she shuns getting less involved or mass-producing products. "We could have our stock pieces built overseas, sell them cheaper, and sell more, but that's a hassle and not the way I

Continued on page 114



Barbara's structures often intermingle closely with trees, sometimes even tying them directly into the design.

More LUX Less Bucks!

Bring the revolution of Natural Sunlight Technology into your home for half the price of the competitors

If you use standard light bulbs, the lighting in your home leaves you in the "dark ages". Standard incandescent bulbs and traditional fluorescent bulbs do not provide the white light necessary for many of your favorite indoor activities. Reading, sewing, and crafts require you to see details and accurate colors. And as we age, our eyes need more light to focus clearly. But your current bulbs, which emit yellowish or greenish light, leave your eyes tired and strained. Well, we looked to the sun for inspiration and developed the SunWhite

lamp. And we priced it much lower than all of the other "daylight" lamps on the market. You can now bring the sun indoors for about half the price that you'd expect.

How did we do it. First we used a technologically advanced bulb that contains rare earth phosphors that emit a purer whiter light than conventional bulbs. These amazing bulbs produce about 2800 lumens in light output creating about 50% more light output than a standard 100 watt bulb from G.E. And we do it efficiently with only 27 watts of power that allows you to pay for this lamp in electricity savings in about 2 years of regular use. To make the value even better, this bulb lasts for 5000 hours or more than twice as long as the best selling bulb. More lux...less bucks!

Don't get burned. We made our bulb cool to the touch. Much of the electrical energy transferred to conventional bulbs is wasted as heat. You can even burn your hands or burn a lampshade with old traditional bulbs. But not the SunWhite bulb. Its cool to the touch even after being lit for hours.

Finally we are offering such a low price because our factory boss wants to be the leader in this new technology. He's invested millions in factory machinery to be the most efficient manufacturer of daylight spectrum lighting. He believes that our SunWhite technology will overwhelm the current lightbulb business and he wants to be the leader in "sunlighting". So don't get ripped off by paying \$99-\$159 for "sunlighting" technology.

We are so sure that you will love this lamp that we are offering a 60 day money back

NOW at the
NEW LOW PRICE
of \$69.95!



- 50% more light output than a standard 100 watt
- Bulb has 5,000 hour life.

Research has shown that daylight spectrum lighting can:

- Improve concentration on schoolwork.
- Make reading easier.
- Ease eyestrain.
- Render colors much more accurately for artists, knitters and needlepoint.

Not all lights are created equal!

GE Reveal™	SunWhite
1352 Lumens	2800 Lumens
100 Watts	27 Watts
750 Hour life	5000 Hour life
Burns Hot to the touch	Cool to the touch

guarantee. If this light doesn't brighten up your world, make your eyes feel better and even lift your mood, just send it back for a full refund of the purchase price. We can offer this extended guarantee because so few of our lamps get returned to us. We have sold thousands of lamps and it's extremely rare to get a return. Don't strain your eyes for one more day.

Not available in stores.

Call now to take advantage of our special direct offer.

SunWhite Full Spectrum Floor Lamp
~~\$129.95~~ \$69.95 + S&H.

Promotional Code FSL151-02
Please mention this when you call.

Toll-Free 24 hours a day
800-482-9143

To order by mail, please call for details.



We can also accept your check by phone.

NEXTTEN
products for your next ten years.

14101 Southcross Drive W.
Dept. FSL151-02
Burnsville, Minnesota 55337

For fastest service, call toll-free 24 hours a day **800-482-9143**

See more innovative products at www.nextten.com

FREE INFORMATION WORTH WRITING FOR

FREE

Have you found all the woodworking products that you need? You will when you send for the useful ideas and FREE product information from these advertisers in WOOD®. You'll get lots of valuable INFORMATION WORTH WRITING FOR — so take a moment to fill out the card in this section and order all the items that interest you. Each advertiser mails the literature or information directly to you.

Adhesives & Finishes

HIPURFORMER™ ADVANCED BONDING SYSTEM

NEW! from the makers of TITEBOND™ wood glues and adhesives. The perfect solution for most bonding needs. Strong, permanent bonds. Waterproof. Ideal for woodworkers, contractors and DIYers. Excellent for construction, remodeling and repair projects. FRANKLIN INTERNATIONAL, INC. **Circle No. 24.**

GORILLA BRAND PREMIUM GLUE

Bonds wood, stone, metal, ceramics, and more. Incredibly strong and versatile—100% waterproof. GORILLA GLUE. **Circle No. 50.**

RUST-OLEUM

"Dream Spaces" inspirational decorating booklet from Rust-Oleum offers an easy, small-project paint approach to creating personalized dream spaces. RUST-OLEUM BRANDS. **Circle No. 115.**

RUST-OLEUM® EPOXYSHIELD®

Want the ultimate garage floor? EPOXYShield provides a durable, long-lasting finish that beautifies as it protects concrete floors. RUST-OLEUM BRANDS. **Circle No. 116.**

THE FINISHING TOUCH

Full color, 12-page guide with complete information on how to refinish wood with ZAR Wood Stain and ZAR Clear Finishes. Excellent tips that help amateurs achieve professional-looking results. UNITED GILSONITE LABORATORIES. **Circle No. 128.**

ZAR® WOOD STAIN & POLYURETHANES HARDWOOD FLOOR FINISHING APPLICATION GUIDE

This informative brochure takes you step-by-step through finishing hardwood floors from choosing the right product, to surface preparation, to application and cleanup. This full-color booklet even gives you tips on how to properly care for your hardwood floors. UNITED GILSONITE LABORATORIES. **Circle No. 154.**

WATERLOX COATINGS CORPORATION

Handmade tung oil-based wood finishes since 1916. WATERLOX COATINGS CORPORATION. **Circle No. 160.**

Bits, Blades, Cutting Tools

AMANA CUTTING TOOL CATALOG

Saw blades, router bits, shaper cutters, boring bits, rosette cutters, planer knives, professional

quality. Free 200 page cutting tool catalog. AMANA TOOL CORP. **Circle No. 167.**

BOSCH WOODWORKING TOOLS

Jigsaws, routers, sanders, planers, benchtop tools, dust collection and accessories make up Bosch Woodworking Tools. Send for more information about the full line of precision equipment. BOSCH POWER TOOLS AND ACCESSORIES. **Circle No. 173.**

FREUD SAW BLADES

This 48-page catalog illustrates the features and benefits for all Freud saw blades. FREUD. **Circle No. 219.**

FREUD ROUTER BITS

All Freud router bits are represented in this 84-page catalog, including more than 130 new bits and sets. FREUD. **Circle No. 232.**

PRODUCTION QUALITY

CARBIDE TIPPED ROUTER BITS

Large discounts. Also, raised panel door sets, shaper cutters, solid carbide bits, Forstner bits, the Merle Clamp and a variety of woodworking tools and supplies. FREE shipping. MLCS LTD. **Circle No. 245.**

WOODLINE USA

Industrial carbide router bits and shaper cutters at the very best prices. 600 items in stock. WOODLINE USA. **Circle No. 310.**

THE WOODWORKER'S CHOICE

Distributors of Oldham Viper and Hickory brand router bits and sets. Over 4,000 woodworking tools and accessories to choose from including Kost Kruncher brand router bit sets, Forstner bits, Tru-Grip & Bessey brand clamps, complete line of dust collection equipment and fittings, abrasives, glues, turning supplies, etc. THE WOODWORKER'S CHOICE, INC. **Circle No. 323.**

Books, Plans and Videos

AMERICAN FURNITURE DESIGN CO.

125+ furniture plans by America's leading craftsmen. 36 x 48 CAD format and comprehensive instructions. Morris chairs, beds, desks, hardware, tools, finishes and books. Catalog. AMERICAN FURNITURE DESIGN CO. **Circle No. 336.**

WOOD MAGAZINE WOODWORKING PLANS

325+ top-quality furniture, shop, and yard-figure woodworking plans from the editors of WOOD® magazine. All have been designed, built, and proven in the WOOD magazine shop to ensure your complete satisfaction. Catalog. WOOD PLANS. **Circle No. 459.**

Carving Supplies

TURNERS AND CARVERS

Largest selection of Henry Taylor turning and carving tools in USA. Also Sorby, OneWay, Foredom, Stewart, Glaser & Sherline. THE CUTTING EDGE. **Circle No. 492.**

MICROPLANE

A totally NEW concept for carving, shaping, forming and smoothing! Stainless steel and razor sharp! MICROPLANE. **Circle No. 505.**

General Woodworking Catalogs

FREE WOOD CRAFT CATALOG FROM CHERRY TREE!

68 full-color pages of plans, parts, kits and supplies for all skill levels. Clocks, whirligigs, dollhouses, door harps, banks and many more attractive items—plus wooden dowels, pegs, wheels, knobs, & more. Tools, paint supplies, stencils, stamps and much more! Wholesale prices available. Catalog. CHERRY TREE TOYS. **Circle No. 563.**

GRIZZLY INDUSTRIAL, INC.

500-page free color catalog of over 12,000 woodworking and metalworking machines, tools and accessories—all at unbeatable prices! GRIZZLY INDUSTRIAL, INC. **Circle No. 583.**

LAGUNA TOOLS

Gives you 20 years of experience in delivering fine quality European machines. Our FREE color catalog will wet your woodworking appetite with our extensive selection of discriminating and award-winning woodworking machines. Circle today to get the most comprehensive selection of bandsaws and combination machines together with our latest innovations in table saws, lathes and much more. Laguna Tools—What woodworking is coming to. LAGUNA TOOLS. **Circle No. 640.**

ROCKLER WOODWORKING & HARDWARE

Rockler Woodworking & Hardware is celebrating 50 years! Rockler is the #1 resource for hinges, slides and other hard-to-find hardware. They also feature an EXCLUSIVE line of jigs, shop tables for band saws, drill presses and routers—as well as exotic and domestic hardwoods. Catalog. ROCKLER WOODWORKING AND HARDWARE. **Circle No. 661.**

SIMP'L PRODUCTS, INC.

POCK'IT JIG KITS for easy pocket hole joinery. DOWL SIMP'L KITS for easy doweling joinery. JOINT'R CLAMP KITS for jointerless joinery and easy STRAIGHT-LINE RIPPING of crooked boards. Our credo: "Keep it simple, easy to use, low cost, and WORKS EVERY TIME." SIMP'L PRODUCTS, INC. **Circle No. 665.**

Hand Tools, Jigs & Clamps

KREG TOOL CO.

If you thought biscuit joinery was great, you'll love pocket hole joinery. Stronger, faster, simpler, better! KREG TOOL. **Circle No. 802.**

MERLE ADJUSTABLE CORNER CLAMP

Adjustable, uniform clamping pressure on all corners. Forces a frame into perfect square. Almost no capacity limitation. Ships with 23 foot reel of steel banding. Aluminum and steel construction. MLCS LTD. **Circle No. 817.**

JAPAN WOODWORKER CATALOG

Woodworkers have discovered the secret of better quality work. 2 year subscription to 88 page catalog. JAPAN WOODWORKER. **Circle No. 830.**

Hardwood & Lumber

BEREA HARDWOODS

Extremely unusual high quality figured lumber, turning blanks and burls for those looking for the best and most unusual wood. BEREA HARDWOODS. **Circle No. 840.**

STEVE H. WALL LUMBER CO.

Quality hardwoods, plywood, and exotic lumber. Will ship UPS or motor freight, wholesale prices. Catalog. STEVE H. WALL LUMBER CO. **Circle No. 856.**

WOODWORKERS SOURCE

Over 100 quality woods from around the world. Lumber veneer, turning stock. Quantity discounts. UPS or truck shipment. Satisfaction guaranteed. WOODWORKERS SOURCE. **Circle No. 869.**

Income Opportunities & Education

GUARDSMAN

Profit from your hobby and capitalize on the multi-billion dollar furniture repair and refinishing industry with a world leader. GUARDSMAN. **Circle No. 908.**

THE WOODWORKING SHOWS

Three days of can't miss education and savings! Learn about the latest hard-to-find tools, equipment, and supplies. Attend seminars for every skill level. Save on everything for your shop. Forty-two shows this season. THE WOODWORKING SHOWS. **Circle No. 934.**

Miscellaneous

AMERICAN STEEL SPAN BUILDINGS

Designed with the do-it-yourselfer in mind. Our buildings are made in a heavy gauge steel with a 20-year warranty. Everything is pre-cut and pre-drilled, and just bolts together. A quality pre-engineered building with style and structural integrity at a price that everyone can afford. 3 models to choose from! AZTEC STEEL CORP. **Circle No. 1064.**

FUTURE STEEL BUILDINGS

Multi-purpose, arch-type structures. Ideal backyard shops & garages. Many models & sizes. Complete kits for the do-it-yourselfer. Free information. FUTURE STEEL BUILDINGS. **Circle No. 1168.**

NISSAN

This December, Nissan introduces the all-new Titan full-size truck. Equipped with a 5.6-liter V8 delivering 300+ horsepower, 375+ lb-ft of torque, and a 5-speed automatic transmission as standard equipment, the Nissan Titan is full-size and then some. NISSAN. **Circle No. 1265.**

PLANNING TO BUILD?

We manufacture a complete range of arch steel buildings, tested and built to withstand wind, snow, rain and seismic conditions. 30 Year Warranty. Since 1980. PIONEER STEEL MFG., LTD. **Circle No. 1298.**

RAINHANDLER

Patented modern gutter. On thousands of homes. No clogging, cleaning or ground erosion. Rugged aluminum. 25-year warranty. RAINHANDLER. **Circle No. 1305.**

WOODLINE USA

Industrial carbide router bits and shaper cutters at the very best prices. 600 items in stock. WOODLINE USA. **Circle No. 1369.**

Power Tools

BAKER PRODUCTS

One of the leading manufacturers of portable sawmills in the industry today. Find out how you too can profit with a Baker. BAKER PRODUCTS. **Circle No. 1428.**

BOSCH BRUTE TOUGH™ DRILL/DRIVERS

Feature a flexible ABS/Nylon housing designed to withstand significant abuse, a unibody powertrain to maintain alignment between clutch, gearbox and motor for extreme durability, and a steel-reinforced collar to enhance chuck durability and protection if dropped. BOSCH POWER TOOLS AND ACCESSORIES. **Circle No. 1459.**

SAVE MONEY, MAKE MONEY

Increase profits by cutting your own lumber with an Accu-Trac portable sawmill. Free catalog. Demonstration video also available. COOK'S SAW MFG., L.L.C. **Circle No. 1480.**

DRILL DOCTOR DRILL BIT SHARPENERS

Sharp drill bits improve the quality of your projects. Sharpens 3/32" to 3/4" bits in about a minute. Fast, easy to use, and precise, the Drill Doctor is what every fine woodworker needs on his workbench. DRILL DOCTOR. **Circle No. 1511.**

FEIN POWER TOOLS

No more bloody knuckle, sore finger sanding. Unique sander, sands along edges and into corners, without bouncing off or running away. The secret is the distinct triangular sanding pad, combined with a high speed oscillation. German made. Brochure shows sander in action. FEIN POWER TOOLS. **Circle No. 1519.**

FREUD POWER TOOLS

Freud offers superior tools at an attractive price. Catalog includes 16 pages of power tools and accessories. FREUD. **Circle No. 1532.**

GENERAL AND GENERAL INTERNATIONAL

All General and General International products are durable and performing. All types of woodworking tools. General cabinet style table saw named "Top Tool" in October 2003 issue of WOOD magazine. GENERAL AND GENERAL INTERNATIONAL. **Circle No. 1552.**

AWARD-WINNING DUST COLLECTION

Air cleaners, dust collectors, cyclone systems, hose, connectors, adaptors, hoods, remote switches, etc. 40-page free catalog. PENN STATE INDUSTRIES. **Circle No. 1623.**

SHOPBOT TOOLS INC.

Be a part of the robotic tool revolution with easy to use computer controlled routers for professional and home-based production. Build crafts, furniture, signs, 3-D carving and much more. SHOPBOT TOOLS INC. **Circle No. 1714.**

10 TOOLS IN 1

Ultimate Home Shop for woodworking or metalworking. Compact, easy to use, built to last. Free catalog. SMITHY SUPERSHOP. **Circle No. 1766.**

PORTABLE SAWMILLS

Convert logs into valuable lumber, whether you're a novice or experience sawyer, using a

Wood-Mizer portable bandsaw mill. Personal sawmills start at \$4,495. Send for our catalog. WOOD-MIZER PRODUCTS. **Circle No. 1805.**

NEW MULTI-DUTY PLANER MOLDS, SANDS & SAWS

Quickly turn low-cost rough lumber into valuable finished stock... create high-profit moldings, tongue & groove, picture frame stock, any custom design. Choose from 12, 18 or 25 inch models... all with infinitely variable power feed. WOODMASTER TOOLS. **Circle No. 1818.**

Project Parts & Materials

ADAMS WOOD PRODUCTS

Adams Wood Products has a free full-color catalog highlighting their line of in stock solid wood components made right here in the good old U.S.A. A new line of kitchen island legs and cabinet onlays are introduced in this catalog edition. ADAMS WOOD PRODUCTS. **Circle No. 1831.**

OSBORNE WOOD PRODUCTS, INC.

Woodturnings are the focus of Osborne Wood Products, Inc. Our company has a free catalog of turnings, which include table legs, kitchen island legs, bunn feet as well as bedposts. Custom woodturnings are made from a large variety of woods. "No order is too small." OSBORNE WOOD PRODUCTS, INC. **Circle No. 1849.**

SCROLLSAW PATTERNS

Up to 74" clocks, 300+ patterns, books, clock parts, saw blades, tools, wood, and more. WILDWOOD DESIGNS. **Circle No. 1857.**

Shop Accessories

FEIN POWER TOOLS

More Power. More Capacity. Fein's Turbo III Portable Vac is the perfect size for big jobs. It makes dust-free sanding and wet/dry cleanup easy and practical. FEIN POWER TOOLS. **Circle No. 1953.**

MOISTURE METERS FOR WOOD

Affordable, reliable moisture meters for wood, pin and pin-less, for all moisture ranges and measuring depths. Moisture meters for concrete and drywall. Free catalog. LIGNOMAT USA, LTD. **Circle No. 2013.**

ONEIDA AIR SYSTEMS

Wood dust collection systems & components. Free shop dust design service. ONEIDA AIR SYSTEMS. **Circle No. 2039.**

Woodturning Supplies

BEREA HARDWOODS

Quality pen kits and other turning kits. We are designers and manufacturers of high quality and unique pen kits for turners. BEREA HARDWOODS. **Circle No. 2127.**

HUGE VARIETY OF PENCRAFTING PRODUCTS

Including: 24 kt kits, lathes, duplicator and templates, wood and finishing supplies. 40-page free catalog. PENN STATE INDUSTRIES. **Circle No. 2156.**

WOODWRITE, LTD.

Precision mini lathes, titanium pen kits, and USA-made pen making supplies plus Turner's Magic polishes. WOODWRITE, LTD. **Circle No. 2182.**

want to do business," she says. "We have recently begun offering plans for a few playhouses, and may produce more." Even with her busy schedule, she finds time for



Walls of the Country Cottage playhouse bear Barbara's whimsical flowers and vines along with birds, bugs, and even a few fairies.

other woodworking, *below*. And she simply enjoys producing projects that help drive kids' imaginations. To learn more, visit barbarabutler.com or call 415/864-6840. ♣

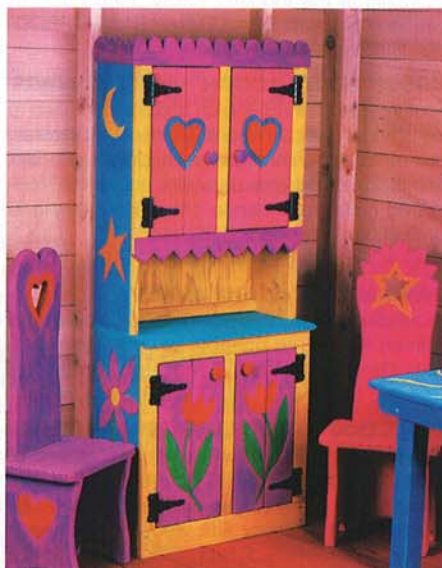

Barbara returns to her roots by crafting about 10 custom furniture pieces per year. "That's my art now, my escape," she says.

SHOP TIP

Keep outdoor colors bright

Barbara Butler tells her clients that they may have to sand and restain their structures every four years. But many don't feel the need for seven or eight years. Here's her advice for creating exterior finishes that last:

- Apply stain liberally to outdoor projects. The stain will weather to an attractive appearance after a year or two of exposure, and then continue to look good for another couple of years before needing to be restained.
- Clean the structure at least twice each year by scrubbing with a stiff bristle brush dipped in a mixture of biodegradable soap and water.
- Protect the stain by refreshing the topcoat every year or two. Use a clear, penetrating-oil exterior finish that contains ultraviolet (UV) light inhibitors.

Talented Creator. Skilled Hobbyist.

BUSINESS OWNER.

You're already two. With Guardsman FurniturePro®, you can become all three!

Guardsman FurniturePro is a network of franchises specializing in furniture-related services. Guardsman FurniturePro has available territories throughout North America.

TRAINING AND SUPPORT PROGRAMS:

- Comprehensive initial training
- Ongoing regional workshops
- Web-based support programs
- 24-hour technical assistance
- Access to fellow FurniturePro franchisees

GUARDSMAN FURNITUREPRO CUSTOMERS:

- Homeowners
- Furniture retailers

- Restaurants and Hotels
- Professional office buildings
- Moving and storage companies

NOT TO MENTION:

- Protected territories
- Affiliation with the most established and respected name and presence in the marketplace
- The support of a \$2.2 billion company, and the largest manufacturer of furniture finishes in the world.
- Affordable franchise entry fees, as low as \$9,500
- Home based with low overhead!



For Franchise Information Call
800.496.6377
www.guardsmanfurniturepro.com.

GUARDSMAN
FurniturePro
The most trusted name in furniture repair

Profit Centers



Furniture Repair - gouges, scratches, burns, water marks, dents and more

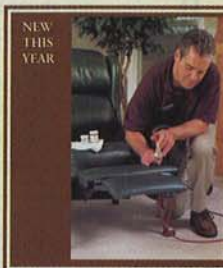

Leather Cleaning and Repair - stain removal, recoloring, and more



Upholstery Services - spot cleaning, panel replacement, seat re-upholstering



Cabinet Refurbishing - cleaning, degreasing, repairing and polishing



Refinishing - complete stripping and refinishing using an eco-friendly, water-based system

shop-proven products

These woodworking wares passed our shop trials

Change router bits in a snap, without tools

For years, router and accessory makers have searched for the Holy Grail of routerdom: a safe and effective collet requiring no wrenches. Craftsman finally unearths the answer with the QuikRout System.

The system consists of a quick-release connector and adapters that mount on 1/4"- or 1/2"-shank router bits. Align the red index marks on the connector and adapter, and with a little pressure the adapter snaps into place. Pull back on the connector's collar, and the bit pops out. The mechanism was a little stiff when I first started testing, but it broke in nicely.

Although the adapters use two different methods to hold the bit (the 1/2" adapters have a collet similar to the one the connector replaces; the 1/4" version grips the bit with set screws), both sizes fit into the 1/2" connector. That means you can switch from a 1/2" bit to a 1/4" bit—and back—in an instant. I also found I could set up matched bits, such as a rail-and-stile set, and swap those bits back and forth without having to test-cut and height-adjust each time.

Installing the QuikRout connector couldn't be easier. Simply remove the nut

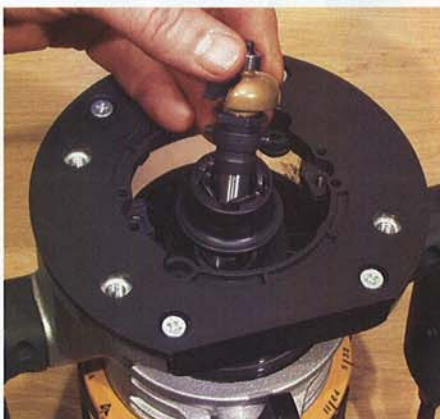

and collet from your Craftsman router (there's one version for current models, another for pre-2003 machines, and a third version for Porter-Cable routers), then thread on the connector where the collet nut used to be. It takes just seconds.

Because moving the individual adapters from bit to bit defeats the purpose of the system, I'll keep a set of QuikRout adapters on my most-used bits. (The 1/2" kit comes with four 1/2"-bit adapters, and additional adapters cost \$10 for a set of three.) For



rarely used bits, I'll either keep an extra adapter on hand, or temporarily replace the connector with the router's factory collet.

The only downside I found is that the 1/2" QuikRout System adds about 5/8" of cutting depth to the router, which can be a problem with long bits. For example, with a 2 1/4"-long straight bit in my fixed-base P-C 690, I couldn't cut any shallower than 3/16". With the 690 in its plunge base, however, that bit retracted completely.

—Tested by John Cebuhar

Craftsman 1/2" QuikRout System

Performance	★★★★☆
Price	\$30

At Sears stores or craftsman.com

Bridgewood cabinet saw boasts beefiness

At first glance, Bridgewood's BW-10LTS 3-hp, left-tilting, cabinet-style tablesaw didn't look like anything special. But one glance under the table told me this saw provides a lot of meat for the money.

It appears that Bridgewood's designers married the massive box trunnions of a Powermatic 66 with the stout trunnion-mounting brackets of a Delta Unisaw. The result is a powerful, vibration-free saw, whose fence scale remains accurate throughout the full bevel range. (Most table-saws vary in blade-to-fence distance as you tilt the blade from 0° to 45°.) Out of the crate, the miter slot of the BW-10LTS was within .0015" of perfectly parallel to the blade, which is excellent. And I would rate the cut quality as above average.

The front-locking Biesemeyer-style fence fell short of the rest of the saw, however. It deflected an acceptable .008" at the arbor

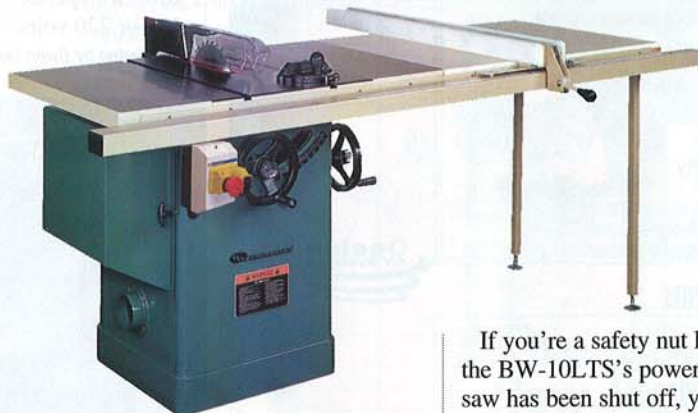

location when ripping a hefty sheet of medium-density fiberboard (MDF), and I found it easy to make the left face parallel to the tabletop using the two top-mounted hexhead screws. But with the left face perpendicular, the right face tilted 1/16" out at the top. And the left face showed signs of scoring from where it was machined at the factory.

If you're a safety nut like me, you'll like the BW-10LTS's power switch: Once the saw has been shut off, you must rotate the switch one-half turn before you can turn it back on.

—Tested by John Cebuhar

Bridgewood BW-10LTS

Performance	★★★★☆
Price	3 hp with 50" fence, \$1,300; optional laminate extension table & legs (shown), \$100

Wilke Machinery
800/235-2100, wilkemach.com

Continued on page 116

Blast gates automatically fire up your dust collector

If you have a central dust-collection system, you know the value of blast gates ("valves" on the ductwork that you open or close to direct suction to the tool in use). After a long day in the shop, you probably do the "blast-gate boogie" in your sleep: Open the gate, walk to the dust collector, turn it on, walk to the tool, make the cut, walk to the collector, shut it off, walk to the tool, close the gate, and so on.

Penn State's Long Ranger MultiGate Switch System saves you steps because every time you open a blast gate on the system, your dust collector comes on automatically. When you close the gate, the collector powers down. No weak suction from gates left open; no hunting for a remote control.

The aluminum gates themselves are spring loaded, so they slam closed when released. That loud "snap!" is disconcerting at first but didn't appear to cause any damage. When you open a gate, you must shift it slightly sideways in its track to engage a stopping pin. The first few times I operated a gate, I jammed it by either pulling too far or shifting it too much, but I quickly got the hang of it.

Installation of the MultiGate system proved super-simple, and I mounted and wired four blast gates on my 4" PVC-pipe system in less than an hour. The gate assemblies nicely fit both the PVC and the 4" flexible hose between the gate and tool. Oddly, there are no keyhole slots or mounting tabs on the relay box to which all the gates are wired, so you're on your own for where to put the thing. I used some self-stick hook-and-loop strips to attach the box to the wall near my collector.

For \$50, you get one MultiGate blast gate, 100' of low-voltage wire, a bag of wire connectors, and the relay box. Additional blast gates (part no. LRGATE) cost only \$11 each, so I did my whole shop for under \$100.

When you order, be sure to specify whether your dust collector operates on 110 or 220 volts.

—Tested by Owen Duvall

Long Ranger MultiGate Switch System

Performance	★★★★☆
Price	\$50
Penn State Industries 800/377-7297, pennstateind.com	



About our product tests

We test hundreds of tools and accessories, but only those that earn at least three stars for performance make the final cut and appear in this section. Our testers this issue include: retired high-school woodworking teacher **John Cebuhar** and **WOOD** magazine projects editor **Owen Duvall**. Both are avid woodworkers. 🌲

REBATE!
\$2 OFF on our POCK'IT JIG KIT

(a great buy Just got better)

THROUGH DEALERS ONLY
\$39.95 (less \$2 rebate)

THE KIT INCLUDES:

- Pocket Jig with Clamp
- 3/8" Steel Step Drill Bit
- Adjustable Stop Collar for Drill Bit
- Hex Wrench for Drill Bit Collar
- A Supply of Square Drive Screws
- 6" Steel Square Drive Bit

PAT. # 6,254,320

You can use this versatile pocket jig kit to make numerous types of joints.

Heavy-duty aluminum extrusion with hardened steel drill bushings.

Shown in use the clamp holds the wood firmly in place for accurate drilling.

The POCK'IT JIG™ KIT is available at these dealers:

- AMAZON.COM 800-635-5140
- EAGLE AMERICA 800-872-2511
- HARTVILLE TOOLS 800-345-2396
- WOODWORKERS SUPPLY 800-645-9292
- McFEELY'S 800-443-7937
- WOODWORKERS WAREHOUSE 800-767-9999
- PRICECUTTER 888-288-2487
- WOODWORKERS CHOICE 800-892-4866
- WOODCRAFT SUPPLY 800-225-1153
- ROCKLER TOOLS 800-279-4441

To receive your rebate, clip & mail us this ad with proof of purchase. (Your sales slip or package bar code will do the trick)

SIMPL PRODUCTS Inc. 21 Bertel Avenue, Mount Vernon, NY 10550
Web Site: woodjigs.com E-Mail: info@woodjigs.com WM 6-7/04

Circle No. 665

Voted BEST Dust Collector!



"Hands down, this machine tested best, so we named it our Top Tool."
WOOD Magazine, Dec. 2003

2hp Commercial

"It's hard to believe there is no dust in my shop. I love to sand now!"
J.G. - Fairfield, IL

- ▶ 1.5 - 25hp Systems
- ▶ Made in USA
- ▶ Duct Design Service
- ▶ Superior Customer Service

Order On-Line!
www.oneida-air.com

Call Us Today! It's FREE!
1.800.732.4065

Oneida Air Systems, Inc. 1001 W. Fayette St., Syracuse, NY 13204

Circle No. 2039



See Us at IWF 2004 Booth 8641

Source Code: W604

This section features advertisers offering products by mail. Additional information can be found in the Free Information section. Please contact the advertiser directly or use the Circle No. to the right of each ad to request information through the Free Information card.

TWC

The Woodworker's Choice

SAVE \$ - check the TWC web site for numerous **BIG BARGAIN** overstock & close-out items such as: saw blades, router bits, shaper cutters, clamps, etc. You'll also find more **BIG \$ SAVINGS** on the **WEEKLY SPECIAL ITEMS** we select from regular TWC catalogs.

www.thewoodworkerschoice.com
CALL TOLL FREE: 1-800-892-4866

New 2" Rotary Shaper

Maximum RPM is 2500

*Dealer inquiries encouraged

Non-clogging Replaceable Blades!

Microplane® sharper cutting tools are manufactured using a patented process which creates an extremely sharp cutting surface. The razor-sharp teeth cut cleanly to create tiny shavings that fall to the surface instead of clouding the air with dust.

Microplane
 Sharper Cutting Tools®

1-800-555-2767 • www.microplane.com

American Made

TOUGH STEEL BUILDINGS

Ideal for Your Woodworking

Perfect for Your Garage

Great for Your Workshop

SAVE UP TO 60%

25 Year Warranty

www.steelspan.com
800-891-6733 ext. 718

Colored Endwalls Available!

BereaHardWoodco. Inc.

Quality Kits for Making Wooden Barrel Pens, Pencils, Roller Balls and Fountain Pens plus other related items Wholesale/Retail

call us or write:
 18745 Sheldon Road
 Middleburg Heights
 Ohio 44130
 (216) 898-8956
 Fax: (216) 898-8962
 Toll Free: 1-877-736-5487
 email: bereahard@aol.com • www.bereahardwoods.com

Adams Wood Products, Inc.™

FURNITURE COMPONENTS
 STOCK ITEMS • NO MINIMUM
 CUSTOM COMPONENTS

FREE COLOR CATALOG

Featuring:

- Bed Posts
- Billiard Legs
- Bun Feet
- Cabinet Onlays
- Corbels
- Finials
- Island Legs
- Table Bases
- Table and Chair Kits
- Tapered Legs
- Turned Legs
- Queen Anne Legs

Island Legs

P.O. Box 728, Dept. M53
 Morristown, TN 37815-0728
 Phone 423-587-2942 • Fax 423-586-2188
www.adamswoodproducts.com

Made in Tennessee by American Craftsmen

Cherry Tree

The Woodworker's Premier Resource for Kits, Plans and Supplies

Toys Phone Toll Free: Kits

1-800-848-4363 ext. 0407WD

Whirligigs
Clocks
Plans & **more!**

FREE CATALOG

Wood Parts Cherry Tree, Inc. **Clock Parts**
 P.O. Box 369 • Belmont, OH 43718

The Cutting Edge, Inc.

Fine Hand Tools For Turners Carvers & All Woodworkers

Hollow Turning Planes & Handtools

Henry Taylor Carving & Power Carving

AutoMach Turning Tools

www.cuttingedgetools.com

7123 SouthWest Fwy Houston TX 77074
713/ 981-9228

Great Scroll Saw Patterns

Clocks
 Plywood
 Saw Blades
 Jewelry Boxes
 Clock Movements
 Candle Holders
 Photo Frames
 Hardwoods
 Furniture
 and
 Much More!

Free Catalog
 Toll Free 1-800-470-9090
www.wildwooddesigns.com
Wildwood Designs
 P.O. Box 976, Richland Center, WI 53581

Circle No. 505

Circle No. 1064

Circle No. 2127

Circle No. 563

Circle No. 492

Circle No. 1857

SUPERSHOP 10-IN-1 WOOD & METAL SHOP

Own a Complete, PRO-QUALITY WOOD SHOP In Just 12 SQUARE FEET!

The HIGH QUALITY, AFFORDABLE ALTERNATIVE for TIGHT SPACE shops!

- Equal or **BETTER QUALITY** and **COSTS LESS** than several one-function machines.
- **10 MOST USED TOOLS IN 1** table saw, lathe, drill press, more!
- 2/2 times **MORE MASSIVE** than other combo machines.
- **ELECTRONIC SPEED** controls, powerful DC motor.
- Perfect for **HOME & PROFESSIONAL** shops.
- **30-DAY RISK FREE** Trial & Industry-Leading Warranties.



10 TOOLS IN JUST 12 SQ. FT.!

CALL TOLL FREE 1-800-476-4849

Or Mail to: **SuperShop** Dept. WOOD, P.O. Box 1517, Ann Arbor, MI 48106

YES! RUSH me all the details on the HIGH QUALITY, AFFORDABLE alternative for TIGHT SPACE wood shops!

Name _____

Address _____

City, _____ State, _____ Zip _____

CNC Routers from Machine Tool Camp

Computer Controlled Router CNC!

Get an Edge Above the Rest!



Engineering Packages From \$90

6 Sizes
OSHAE-Stop
G&M Code, 350"/min
CAD/CAM Ready
Hobby, Industry, School
Easy to Build with
Common Shop Tools

You Build It!
You Make \$\$

715-532-5308
www.MachineToolCamp.com

BUILT TO LAST AND PRICED TO SELL...



Compare our everyday price for our 25'x40' building:

\$4,990
FRONT END OPTIONAL

- **EASY DO IT YOURSELF** • **30-YEAR WARRANTY** • **100% USEABLE SPACE**
- Many sizes, shapes & applications! • Tough, rugged building - lasts! • Heavy gauge Galvalume steel • Easy to finish trussless interior • Totally maintenance free!

PIONEER STEEL BUILDINGS GO FACTORY DIRECT
800-668-5422
www.pioneersteel.com 23 YEARS OF REPUTATION BUILT OF STEEL

MISSION BED & NIGHT STAND

Introducing the finest plan on the market today! Pages of directions and 36 by 48 CAD generated plan. This plan only requires a limited amount of lumber

FREE CATALOG



AMERICAN FURNITURE DESIGN
P.O. BOX 300100 ESCONDIDO, CA 92030
BED AND NIGHT STAND PLAN \$21.95 +\$4.50 S&H
760 743-6923
www.americanfurnituredsn.com

Plan #236

HARDWOODS
Lumber · Veneer · Turning Stock

Over 100 Quality Hardwoods From Around the World

exoticwoods.net
Wood Descriptions · Prices · Current Specials
Secure On-Line Ordering

WOODWORKERS Source
5402 S. 40th Street · Phoenix, AZ 85040
800.423.2450

RUGGED, HIGH-PERFORMANCE PORTABLE BAND SAWMILLS.

The Model "EZ" Baker Portable Band Sawmill.



Best PRICE

PERFECT FOR FARMERS, LOG HOME BUILDERS, WOODWORKERS, CONSERVATIONISTS, AND THE WEEKEND WARRIOR. CUTS UP TO 20" DIAMETER LOG.

- Powerful 16-HP gasoline engine.
- Durably built of aluminum and stainless steel.
- "E-Z" to maintain.
- "E-Z" on the pocketbook.
- "E-Z" to transport.
- "E-Z" to set up and run.
- Modular design allows you to add extensions to accommodate any log length.

BAKER Products PO Box 128
Ellington, Missouri 63638
U.S.A.
www.baker-online.com
Email: info@baker-online.com
Fax: 573-663-2787
Phone: 573-663-3133
800-548-6914

Tung Oil

DEFINING THE BEST - WATERLOX



n: a yellow oil pressed from the seeds of the tung tree [syn: Chinawood oil]

Tung Oil has been in existence for centuries. It is pressed from the seeds of the tung tree. Waterlox original family formulas are handmade with tung oil and resin, creating a unique blend that bonds with the fibers of the wood surface. Since 1916, Waterlox continues to offer a durable and beautiful hand-rubbed look! It is easy to apply and can be maintained beautifully with little effort. Choose Waterlox for all wood surfaces: floors; woodwork; cabinetry; doors; windows and more!

Ask us about our Original Sealer/Finish, Satin Finish and High Gloss Finish. Contact us today by e-mail: info@waterlox.com, or call 1-800-321-0377.

www.waterlox.com

Time Tested Finishes 

FUTURE STEEL
FACTORY-DIRECT WHOLESALE PRICES!!



Call for your FREE Catalog!

Many Models & Sizes Available
Ideal Multi-Purpose Structures
All-Steel 100% Clear-Span Interior

Easy Self-Assembly for the "Do-it-Yourself"

1-800-668-5111 ext.1333

Make More Money!
Sawing Lumber Made Easy



FREE Magazine
Call 1-800-473-4804
Mention Code BHG-04

MP-32 Sawmill
Build Your Own Home, Barn, Furniture...

5 Money Saving Package Deals!

SIMONDS Band Blades
COOKS SAWMILL Manufacturing
Leaders in Bandsaw Technology
www.cooksaw.com

Circle No. 160

OWN YOUR OWN SAWMILL

Wood-Mizer®



Prices as low as
\$4,995!

(FINANCING AVAILABLE!)

Call **1.800.553.0182**
www.woodmizer.com

TRUST.
Wood-Mizer®

WM604G

Have you discovered the **TORMEK** way of sharpening?
Now with **Micro Adjust** for precision edge setting.



Log on to the Tormek website www.tormek.us for full details of the TORMEK System and all sources.

You will also find the entire TORMEK handbook, which contains the basics of edge tool sharpening and detailed instructions how to sharpen all your woodworking tools as well as knives and scissors.

U.S.A. 1-800-5-Tormek
Canada 1-877-2-Tormek



Circle No. 1785

WoodWrite Ltd.

Precision Mini-Lathes
Automatic and CNC



Titanium Pen Kits
Pre-cut & Pre-drilled Pen Blanks

Turner's Magic Polishes

www.WoodWriteLtd.com

Ph: 888-966-3974

Circle No. 1389

Dust Collection Ductwork

Ready-to-Ship.

▶ **FREE Shipping***

*48 States - Restrictions Apply
-\$100 Minimum Purchase Required

▶ **FREE Ductwork Catalog**



Call Us Today!

1.800.732.4065 www.oneida-air.com

Circle No. 2039

WOOD MOISTURE METERS



- For the Woodworker -
Moisture problems such as shrinking or warping can ruin the best piece ever built. Measure the moisture with a moisture meter to be sure the wood is dry. Call for new color brochure.

- Lignomat USA -
Po Box 30145
Portland, OR
97294 -- USA

Lignomat :: 800-227-2105

Circle No. 2013

Need a separate space for your workshop?



...get it with a **Miracle Truss**
Pre-engineered Steel Frame
Building System.



NO MORE DUST IN THE HOUSE!

- Unique steel web-frame design yields 100% usable space while providing unmatched strength to withstand extreme weather.
- Fast & easy do-it-yourself assembly doesn't require skilled labor or heavy equipment.
- Engineered to utilize standard-sized wood purlins & girts for simple insulating and finish-off.
- Customizable to meet your needs with a wide variety of sizes, styles and 19 contemporary colors.

FACTORY-DIRECT PRICES

34' x 48' — ONLY \$9,373
(a \$17,340 value)

Includes steel frames & endwalls, galv. sheeting, hardware, trim and assembly plans.

All other sizes at great prices too!

MIRACLETRUSS®

1-866-552-6068

www.miracletruss.com

WOOD

The Japan Woodworker's Catalog is . . .

loaded with the best tools you can get your hands on. In our catalog you will find a huge selection of Japanese saws, waterstones, chisels, planes, carving tools, cutlery and books. Send \$3.00 for our catalog and supplements during the next two years.

THE JAPAN WOODWORKER
1731 Clement E-32, Alameda, CA 94501
Phone 1-800-537-7820
www.japanwoodworker.com

Circle No. 830

what's ahead

Come celebrate our *20th anniversary* in this special September issue (on sale **July 20**)

Projects to build over several weeks or just a weekend

FEATURED PROJECT



Modular entertainment center . . . and more

Here it is: Our special 20th-anniversary project! You can build and arrange the furniture pieces in this collection to suit a TV of nearly any size and shape. Better still, its base doubles as a coffee table, and you'll find matching end tables, too.



Jewelry box

Although you can build this project in no time, it is sure to be treasured by its recipient for all time.



Business card holder

Propped open on a desk, or folded up inside a shirt pocket, this slim carrier delivers your calling cards in style.



Flower aquarium base

Watch your garden bloom again in this water-filled globe supported by your shop-made base.

Tools, Tips, and Techniques

GLUE TEST



Sticky situation

See how 16 glues perform in our tests of strength, open time, and water resistance, among other things.



Save money on tools

Want to buy top tools at rock-bottom prices? Of course! Products editor Dave Campbell shows you how.



Guide to air-tight joints

Uncover the secrets to precise machine- or hand-cut joinery, as well as simple fixes for common flaws.

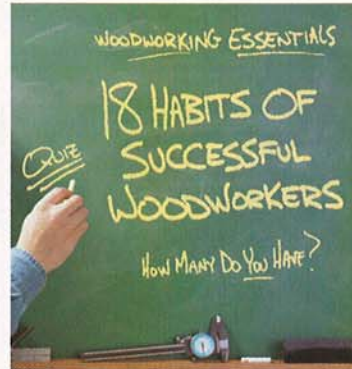

Improve your woodworking

Take this fun quiz to learn how many habits of successful woodworkers you have and how to master those you don't.



GENERAL

**GENERAL
INTERNATIONAL**

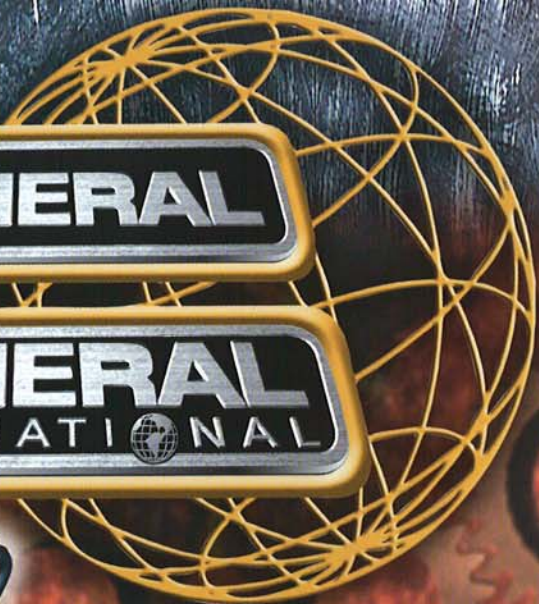

IWF 

2004

August 26-29, 2004
Atlanta, Georgia USA
Georgia World Congress Center
www.iwf2004.com
BOOTH 6063 HALL B



WWW.GENERAL.CA

Makita®

BUY

12" Dual Slide Compound Miter Saw

LS1212



BUY

10" Dual Slide Compound Miter Saw

LS1013/LS1013F (with Light)



1-800-4MAKITA
MAKITATOOLS.COM

POWER. PERFORMANCE. PRECISION.

PLUS

FREE 12V Cordless Impact Driver or 14.4V Cordless Driver-Drill make them your perfect choice

GET FREE

By Mail



12V Cordless Impact Driver Kit
6914DWAE

Up To

\$200.00 Value

GET FREE

By Mail



14.4V Cordless Driver-Drill Kit
6228DWE

Up To

\$150.00 Value

Offer good in U.S. only February 1, 2004 - July 31, 2004
See makitatools.com for redemption forms

POWER



Dynamically balanced, direct drive motor with dual ball bearings never slips or bogs down like belt drive units

PERFORMANCE



Dual rails supported by dual linear ball bearings for a "Dead-on" cut that never needs adjusting

PRECISION



Single piece, precision machined aluminum base remains flat and true and never needs alignment