

**4 New**  
Shop Projects

HAND PLANES – WHAT YOU NEED TO KNOW

# ShopNotes®

Vol. 11

Issue 65

## ***Our Best Bench Yet*** ***Loaded with Easy-to-Build Features***

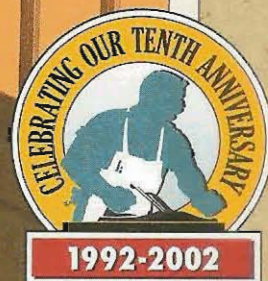

- **PERFECT MITERS**  
**In Just Minutes**
- **ADJUSTABLE V-BLOCK**  
**Our New Drilling**  
**System Handles It All**
- **NO MORE SCRATCHES**  
**Edge Sander Makes It Quick & Easy**



# ShopNotes

Issue 65

September 2002

**PUBLISHER** Donald B. Peschke

**EDITOR** Terry J. Strohmman

**ASSOCIATE EDITORS** Bryan Nelson  
Vincent Ancona

**ART DIRECTOR** Cary Christensen

**SR. GRAPHIC DESIGNER** Kurt Schultz

**SENIOR ILLUSTRATORS** Roger Reiland  
Mark Higdon

## CREATIVE RESOURCES

*Creative Director:* Ted Kralceek • *Sr. Project Designers:* Ken Munkel, Kent Welsh, Ryan Mimick, Chris Fitch • *Shop Craftsmen:* Steve Curtis, Steve Johnson • *Sr. Photographer:* Crayola England

## SPECIAL PUBLICATIONS

*Corp. V.P.:* Douglas L. Hicks • *Art Director:* Douglas A. FEnt • *Sr. Graphic Designer:* Chris Glowacki • *Graphic Designers:* Vu Nguyen, Jonathan Eike • *Associate Editor:* Craig Rueggsegger • *Asst. Editor:* Joel A. Hess • *Editorial Intern:* Cindy Thurmond

## CIRCULATION

*Subscriber Services Director:* Sandy Baum • *New Business Dir.:* Wayne J. Klingbeil • *Circulation Marketing Analyst:* Kris Schlemmer • *Assoc. Circ. Marketing Analyst:* Paula M. DeMatteis • *Renewal Manager:* Paige Rogers • *Sr. Graphic Designers:* Mark Hayes, Robin Friend • *Billing & Collections Mgr.:* Rebecca Cunningham • *Multimedia Promotion Mgr.:* Rick Junkins • *Promotion Analyst:* Patrick Walsh

## CORPORATE SERVICES

*V.P. of Finance:* Mary R. Scheve • *Controller:* Robin K. Hutchinson • *Sr. Acct.:* Laura J. Thomas • *Accts. Payable:* Mary J. Schultz • *Accts. Receivable:* Margo Petrus • *Prod. Dir.:* George Chmieluz • *Electronic Pub. Dir.:* Douglas M. Lidster • *System Admin.:* Cris Schwanebeck • *P.C. Maint. Tech.:* Robert D. Cook • *Pre-Press Image Specialists:* Troy Clark, Minnette Johnson • *New Media Mgr.:* Gordon C. Gaippe • *Multimedia Art Dir.:* Engene Pedersen • *Web Server Admin.:* Carol Schoeppler • *Web Content Mgrs.:* David Briggs, Sue M. Mos • *Web Designer:* Kara Blessing • *Prof. Dev. Dir.:* Michal Sigel • *H. R. Asst.:* Kirsten Koelke • *Office Mgr.:* Natalie Lonsdale • *Facilities Mgr.:* Kurt Johnson • *Receptionist:* Jeanne Johnson • *Mail Room Clerk:* Lou Webber

## MAIL ORDER

*Operations Director:* Bob Baker • *Customer Service Mgr.:* Jennie Enos • *Warehouse Supr.:* Nancy Johnson • *Buyer:* Linda Jones • *Admin. Asst.:* Nancy Downey • *Tech. Rep.:* John Audette • *Sr. Cust. Serv. Reps.:* Tammy Truckenbrod, Anna Cox, Deborah Rich, April Revell • *Cust. Serv. Reps.:* Valerie Jo Riley, Kim Harlan • *Warehouse:* Sylvia Carey

## WOODSMITH STORE

*Manager:* Dave Larson • *Asst. Mgr.:* Tim Thelen • *Sales Staff:* Wendell Stone, Larry Morrison, Gregory Kanzlarich, Mark Johnson • *Office Mgr.:* Vicki Edwards

ShopNotes® (ISSN 1062-9696) is published bimonthly (Jan., March, May, July, Sept., Nov.) by August Home Publishing, 2200 Grand, Des Moines, IA 50312.

ShopNotes® is a registered trademark of August Home Publishing © Copyright 2002 by August Home Publishing. All rights reserved. Subscriptions: Single copy: \$4.95. One year subscription (6 issues): \$27.95. Canada/International add \$10 per year. U.S. funds. Periodicals Postage Paid at Des Moines, IA and at additional mailing offices.

Postmaster: Send change of address to ShopNotes, P.O. Box 37103, Boone, IA 50037-2103.

Subscription Questions? Write to: ShopNotes Customer Service, P.O. Box 842, Des Moines, IA 50304-9961. Or call 1-800-362-5854, 8:00 am to 5:00 pm, Central Time, weekdays. FAX 515-283-0447

E-mail: ShopNotes@shopnotes.com  
Internet: http://www.shopnotes.com

PRINTED IN U.S.A.

## EDITOR'S NOTE

# Cutoffs

**Q**uick — what comes to mind when you think of a *traditional-style* workbench. For me it's beefy mortise and tenon construction, a thick glued-up hardwood top, and large, heavy-duty vises.

Now there's no doubt that these features make for a great workbench. After all, they've proven themselves in woodworking shops for hundreds of years. The only problem is this type of bench usually requires investing a substantial amount of time, effort, and materials to build.

So what if you want to build a traditional style workbench — without spending weeks or even months in the process? That was the goal as we began working on the feature project in this issue — a new-style, traditional woodworking bench.

The first step was to tackle the base construction. It had to be sturdy and easy to build. We started with two end assemblies that couldn't be simpler — just two thick posts connected by a plywood panel. But the results are impressive — a rock-solid assembly that won't rack or twist.

To complete the base, we tied the end assemblies together with a

couple of stretchers. Here again, there's no tricky joinery involved. All you need to do is drill a few holes and install some draw bolts.

Besides being easy to install, this draw-bolt system has a couple of other benefits. First, you can “snug-up” the joint when the wood *shrinks* with changes in humidity. And you can take the base apart if you want to move the bench.

As for the top of our bench, again we took a different approach. Instead of traditional hardwood we chose MDF. It's flat, durable, and inexpensive. Plus it goes together quickly — all you have to do is cut it to size and glue three pieces together.

Of course a woodworking bench wouldn't be complete without vises. We chose two different styles for our bench: a simple bolt-on front vise and a unique twin-screw end vise.

About the only thing that we didn't address with this bench was storage. But don't worry, we're working on a storage system for the next issue.

Terry

## Be included, as a part of the Woodworking Shop Tours

On the Web

Visit other *ShopNotes* subscribers' workshops and see photos of the shop projects they've built. It's all online at Woodworking Shop Tours on the *ShopNotes* web site:

[www.ShopNotes.com](http://www.ShopNotes.com)

We want you to be part of our shop tours! To submit photos of your favorite *ShopNotes* projects or views of your shop, just follow the instructions you'll find on our web site.

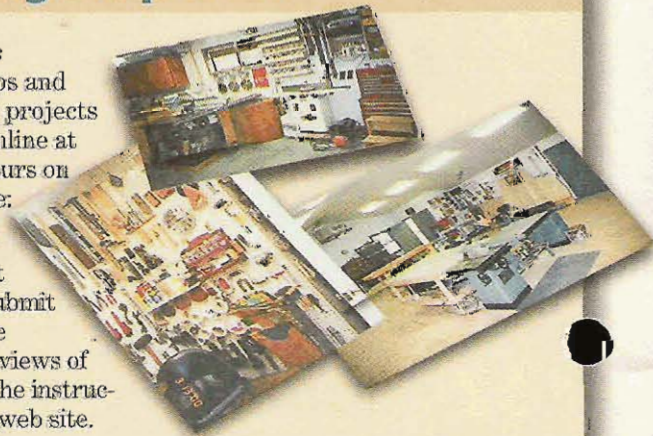

# Contents

## Features

### Adjustable V-Block System \_\_\_\_\_ 6

*You've never seen a jig that looks — or works — like this one. This is more than just a V-block. It's a whole drill press system. With it, you'll be able to drill accurate holes in anything from simple dowels to irregular-shaped objects.*

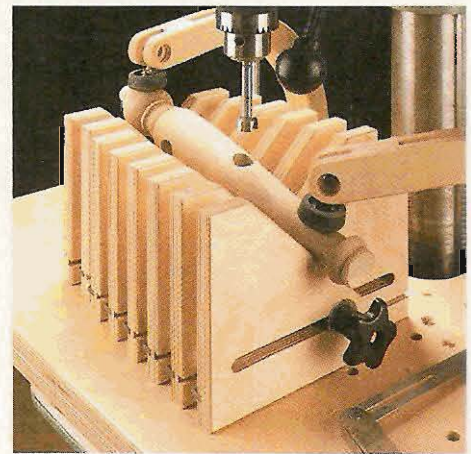

Adjustable V-Block page 6

### Shooting Board \_\_\_\_\_ 12

*Need to "tweak" a mitered joint or plane the end of a workpiece perfectly square? With this shop-made shooting board, you can slice razor-thin shavings for a perfect fit.*



Shooting Board page 12

### Using a Shooting Board \_\_\_\_\_ 16

*Using the shooting board starts with setting it up for your hand plane. Then get the most out of it with a few handy tips and techniques that will work with any shooting board.*

### Heavy-Duty Workbench \_\_\_\_\_ 18

*This heavy-duty workbench incorporates easy-to-build features with up-to-date materials and hardware. With its rock-solid construction and two handy vises, this bench can handle just about anything you can throw at it.*



Workbench page 18

### Edge-Sanding Block \_\_\_\_\_ 30

*There's no doubt sanding is a hassle — especially when it comes to plywood edging. Our adjustable, edge-sanding block makes sanding less of a chore and more accurate.*

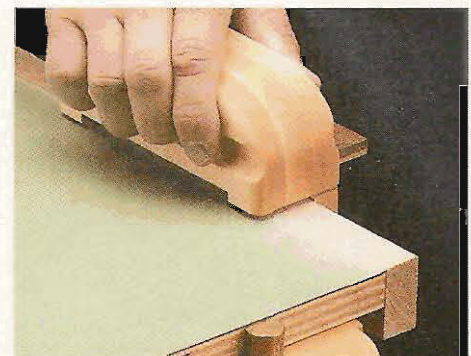

Edge-Sanding Block page 30

## Departments

### Readers' Tips \_\_\_\_\_ 4

*Shop-tested tips to solve common woodworking problems.*

### Shop Talk \_\_\_\_\_ 32

*When it comes to hand planes, it's hard to know exactly what you need. In this issue, learn about some basic planes and what they are used for.*

### Tool Chest \_\_\_\_\_ 34

*Here's a look at a couple products that are designed to make your woodworking safer and more enjoyable.*

### Sources \_\_\_\_\_ 35

*Mail-order sources and supplies to help you complete the projects featured in this issue.*

# Readers' Tips

## Box Fan Filter

Like a lot of woodworkers, I made a cheap air cleaner for dust in my shop by attaching a furnace filter to a box fan. I just set the fan on my workbench whenever I'm sanding. It works so well that I decided to make a more permanent air cleaner.

I mounted the fan overhead, attaching it to the floor joists in my shop, see drawing. (You could mount it to the rafters if you have a garage shop.) I made a couple of brackets that bolt to the sides of the fan.

A hardboard strip attached to the bottom of each bracket creates a ledge for supporting the furnace filter, see detail in drawing at right. The brackets then get screwed directly to the joists.

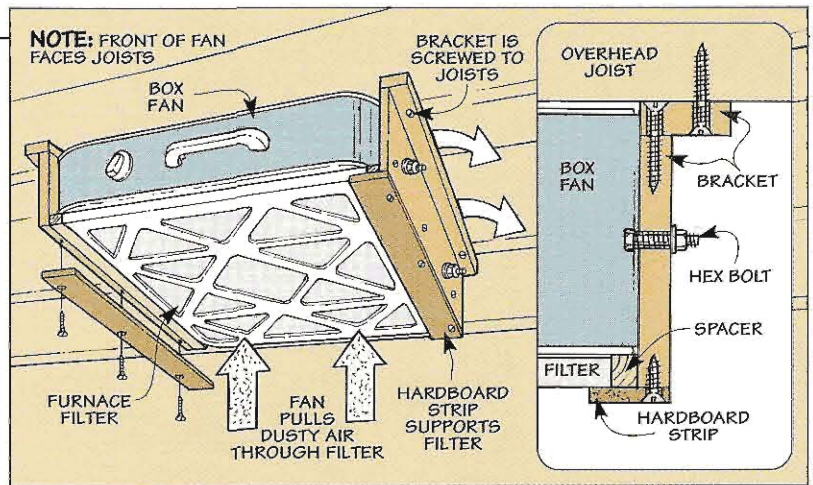

When it's turned on, the fan pulls the dusty air up and through the filter. The filtered air is then expelled into the cavity between the joists, where it can return to the shop. And

when the filter gets clogged up with dust, I just slide it out and blow it off, or replace it altogether.

*Kevin McLaughlin  
Helena, Alabama*

## Knock-Down Sawhorse Cutting Grid

Cutting down full sheets of plywood with a circular saw has always been a bit awkward. I usually lay the plywood sheet on supports on the floor and then have to crawl around to make the cut. But recently, I came

up with a solution that makes the process a lot easier.

I made a simple cutting grid that fits over a pair of sawhorses, see drawing below. The grid is made up of interlocking strips of  $\frac{3}{4}$ " plywood.

The strips are all 4" wide. I cut two 8-foot long strips for the main rails and five 4-foot long strips for the cross rails. Then all the strips are notched so that they interlock to create a grid. I also notched the bottom edge of the long strips and the top edge of the sawhorses to hold the grid in place and keep it from moving.

The grid is assembled on top of the sawhorses by simply sliding the pieces together. Then I put the sheet of plywood I want to cut on top of the grid. I set the blade on my saw so that it cuts through the plywood and just barely starts to cut into the top edges of the grid. (If the rails get chewed up through use, it's a simple matter to make some new ones.)

The nice thing about this cutting grid is that when I'm done using it I can simply disassemble it and store it out of the way.

*Jay Reichwein  
La Verne, California*

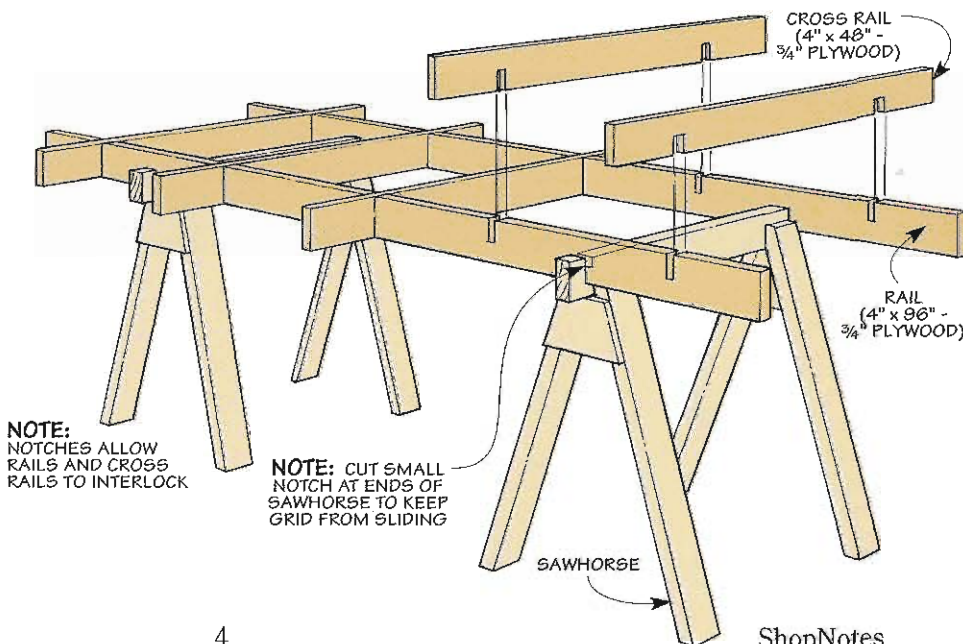

### Free Tips ON THE WEB

Get more wood-working tips free.

Visit us on the Web at [ShopNotes.com](http://ShopNotes.com)

Sign up to receive a free shop tip by email every week.

## Clamping Tapered Pieces

■ As part of a recent remodeling job, I had to build several tapered, square columns for a living room. Each column was over six feet high and was constructed with mitered corners. Making the columns was the easy part—the challenge was in finding a way to clamp them together. Because these pieces were tapered, none of the clamps I had in my shop would work.

So I made some special “clamps” out of  $\frac{3}{4}$ "-thick plywood. I cut several squares and drilled a hole near each corner. Then I cut a square opening out of the middle with a jig saw, see drawings at far right. I made each opening progressively larger so that the squares would rest at different points on the column. Finally, I rounded over the sharp edges on the inside of each opening with a router and a round-over bit.

After gluing up a column, I simply slide the squares over the end of the column one at a time, pressing each one down firmly, see detail ‘a.’ The squares held the column together

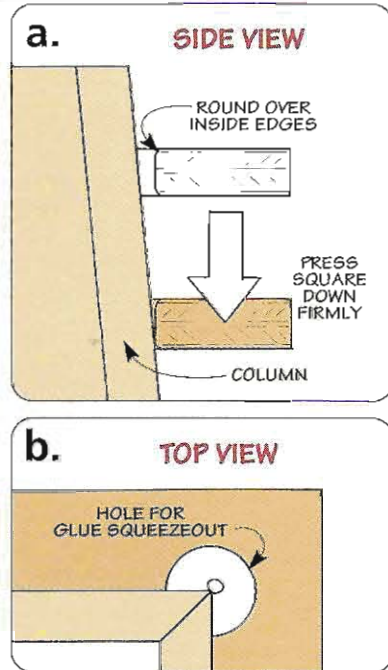

tightly while the glue set up. And the holes in the corners of the squares provided space for any glue squeezeout, see detail ‘b.’

*Richard Beazer  
Rigby, Idaho*

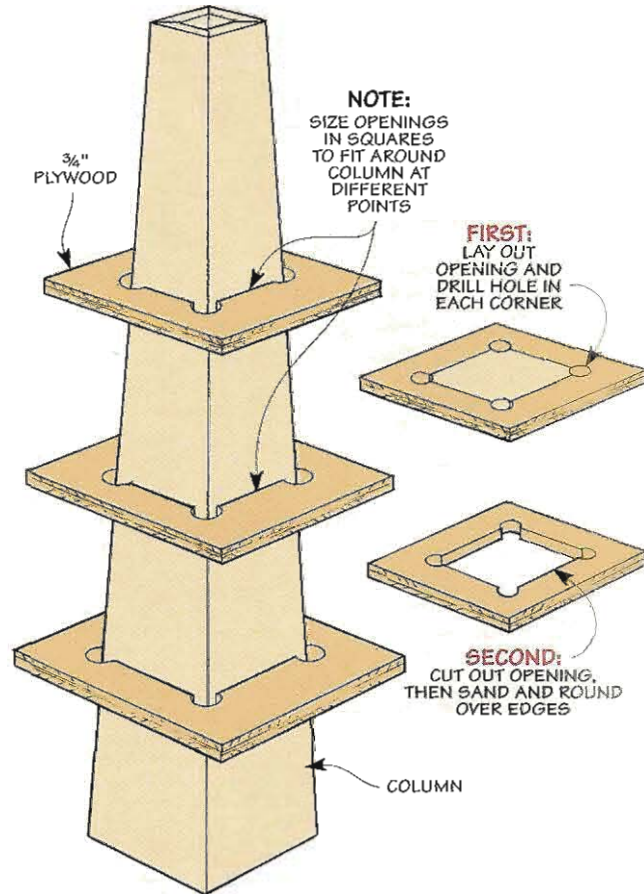

## Router Crank

■ The knob on my plunge router is small and hard to turn. To make it easier to use, I came up with a simple hand crank. The crank is nothing more than a piece of plywood with a large hole to match the size of the knob, see drawing below.

I cut a slit in the edge of the plywood crank and then used a screw to pinch the crank around the knob on the router, see detail.

To make a handle for the crank, I drilled a hole lengthwise through a short wood dowel. Finally, a carriage

bolt, washer, and jam nut secure the handle to the crank.

With this crank installed on my router, it's now a lot easier to make adjustments to the height of the bit.

*Brian Krum  
Kokomo, Indiana*

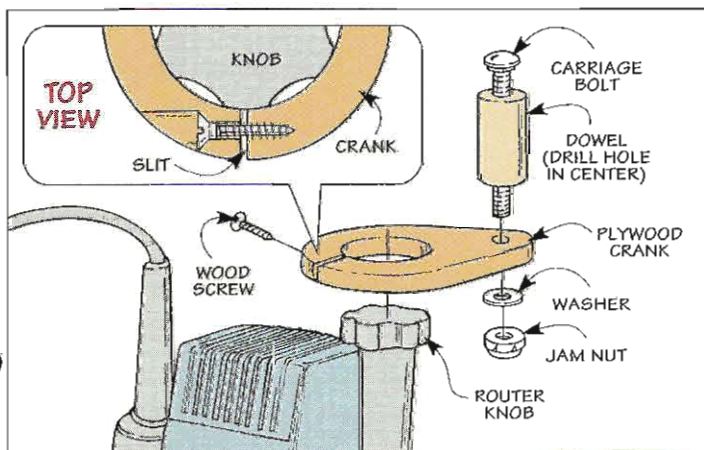

## Send in Your Shop Tips

If you have a unique shop tip, we'd like to consider featuring it in one or more of our print or electronic publications.

We'll pay up to \$200 for a tip we publish. Just write down the tip and mail it to *ShopNotes*, Attn.: Readers' Tips, 2200 Grand Ave., Des Moines, IA 50312. Or FAX it to 515-282-6741, or send us an e-mail at [shopnotes@shopnotes.com](mailto:shopnotes@shopnotes.com). Please include your name, address and daytime phone number in case we have any questions.

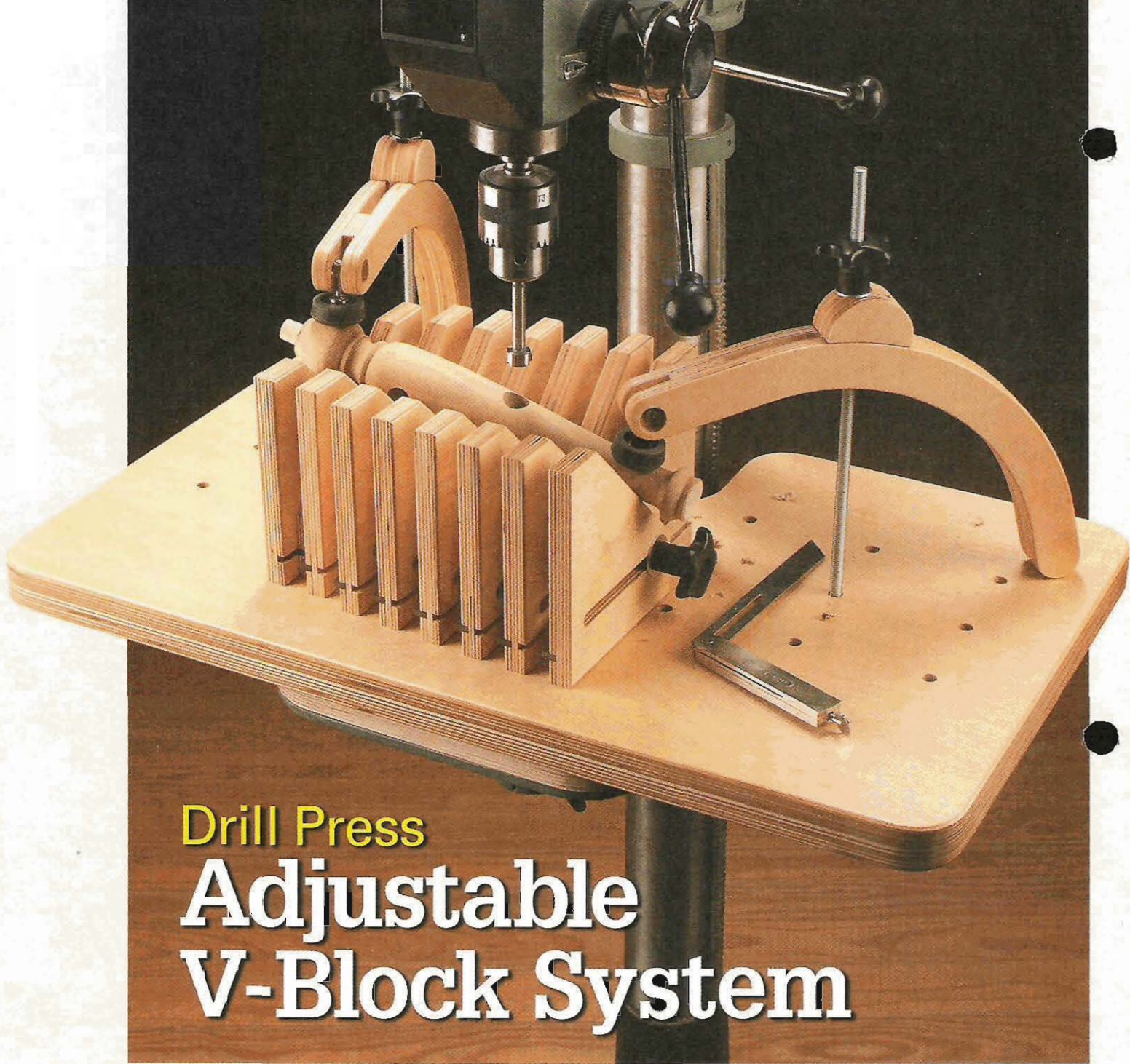

## Drill Press Adjustable V-Block System

*Angled holes and odd-shaped workpieces are no match for this handy drill press accessory.*

If you've ever tried to drill a hole in a dowel or odd-shaped object (like a turned leg), you probably know how frustrating a job it can be. It's a real challenge to hold these kinds of workpieces steady and accurately on the flat table of a drill press. And it's even trickier if you have to drill an angled hole. Usually, I wind up cobbling together some jury-rigged device to support the workpiece in question. But since building this adjustable V-block system, that's no longer a problem.

It only takes one look to know that this isn't your ordinary, run-of-the-mill V-block. Instead of being made out of a solid piece of wood, this V-block is made up of sliding "plates." The plates interlock like fingers, and

they slide in or out independently to conform to an infinite number of shapes and sizes. From long dowels to cabriole legs to perfect spheres, this V-block is versatile enough to hold just about anything.

**Table** – The V-block is only part of the system, however. There is also a drill press table that you can make to be used with the V-block. It bolts right on to your standard drill press table and provides a large, flat surface for the V-block to sit on. But more importantly, it also features some unusual hold-downs that can get a secure grip on awkward workpieces. In fact, the table and hold-downs work so well that you might want to use them even when you're not using the V-block.

**EXPLODED VIEW**  
OVERALL DIMENSIONS:  
20"D x 30"W x 14"H

**ShopNotes** To download  
a free Cutting  
Diagram for  
this project, go to:  
[www.shopnotes.com](http://www.shopnotes.com)

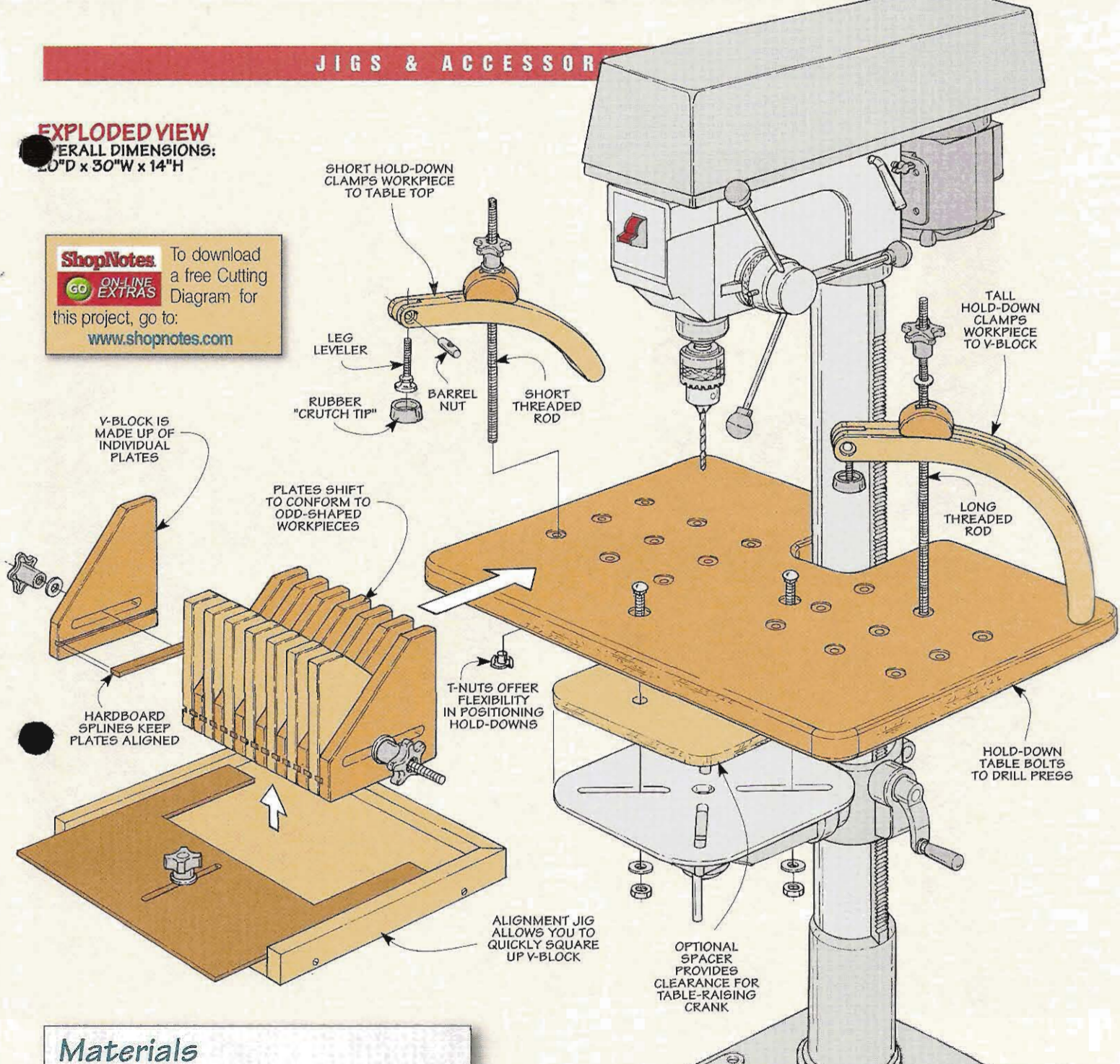

**Materials**

**V-Block**

- A Plates (15) 6 1/2 x 6 - 3/4 Plywood
- B Splines (14) 7/16 x 6 - 1/4 Hardboard

**Alignment Jig**

- C Base (1) 12 x 15 5/16 - 3/4 Plywood
- D Side Rails (2) 3/4 x 1 1/2 - 12 3/4
- E Back Rail (1) 3/4 x 1 1/2 - 16 15/16
- F Alignment Plate (1) 11 1/2 x 15 1/4 - 1/4 Hardboard

**Table**

- G Table (1) 20 x 30 - 1/2 Plywood

**Hold-Downs**

- H Tall Hold-Downs (2) 10 x 12 - 1 1/2 Plywood
- I Short Hold-Downs (2) 4 1/2 x 10 11/16 - 1 1/2 Plywood
- J Clamp Blocks (4) 2 1/2 x 1 5/16 - 1 1/2 Plywood

**Hardware**

- (6) 3/8" Star Knobs (w/thru hole)
- (1) 3/8" Threaded Rod (4 ft.)
- (7) 3/8" Washers
- (19) 3/8" T-Nuts
- (1) 3/8" Star Knob (w/1"-long stud)
- (4) 1/4" Barrel Nuts
- (4) 1/4" Leg Levelers
- (6) #8 x 1 1/2" Fh Woodscrews
- (4) 1"-Dia. Rubber Crutch Tips
- (8) 3/8"-Dia. Dowels (1/2" long)

Also Needed: Carriage bolts, nuts, and washers for attaching table to drill press

# V-Block

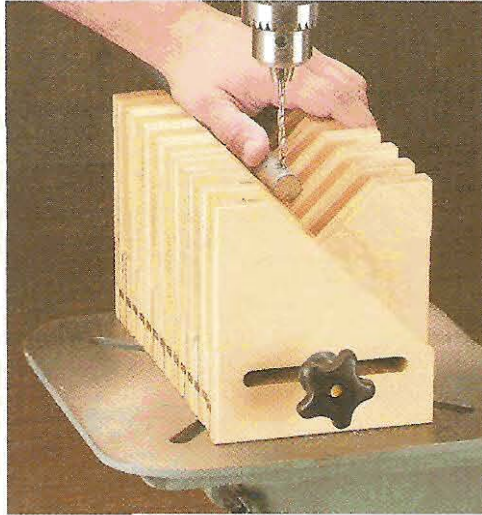

▲ **V-Block.** The V-block makes it easy to drill a hole in a dowel or round stock. The individual plates of the V-block can be adjusted for different diameters.

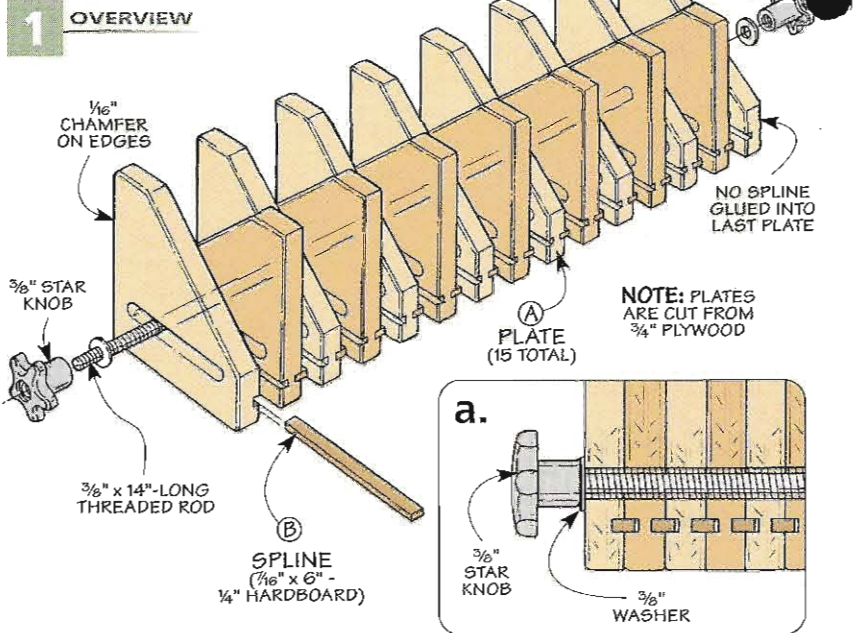

With its fifteen interlocking plates, this V-block looks like the backbone from some sort of pre-historic creature. But building the V-block is made a little easier due to the fact that all the plates are more or less identical (Figure 1).

As you can see in Figure 2, each plate (A) starts off as a rectangular piece of 3/4" plywood. After cutting all the plates to size, the next step is to cut a groove on each side of the plate. (Note that the two end plates

are grooved on only one side.) Later, splines will be fitted to these grooves in order to keep the plates aligned.

The grooves are sized to match the thickness of the 1/4" hardboard that will be used to make the splines. Figure 3 shows how I made these grooves. I cut each groove in two passes, using a single saw blade.

After cutting the grooves, a slot is cut in each plate for the hardware that will be used to hold the plates together. Making each slot is a two-

step process. First, 3/8"-dia. holes are drilled to establish the ends of each slot. (To do this, I set up a fence with a stop block on my drill press.) Then, the material between the two holes is removed on a router table in several passes, as shown in Figure 4.

Once you've finished cutting the slots in the plates, you can cut each plate to its final shape by mitering one corner. I did this on the table saw, setting up an auxiliary fence and a stop block on my miter gauge, as shown in Figure 5. The last step to complete the plates is to rout a 1/16" chamfer around the edges.

**Splines** – Hardboard splines are used to keep the plates aligned. There's nothing complicated about these. Each spline (B) is cut from 1/4" hardboard, as shown in Figure 1.

Each plate has a spline glued into one side (except for one of the end plates, which has no splines). Take a good look at Figure 1 to see how the splines and plates are oriented. But before ever picking up my glue bottle, I dry assembled the splines and plates to help keep everything organized.

**Hardware** – After the splines are glued in place, the plates can be assembled and the hardware added.

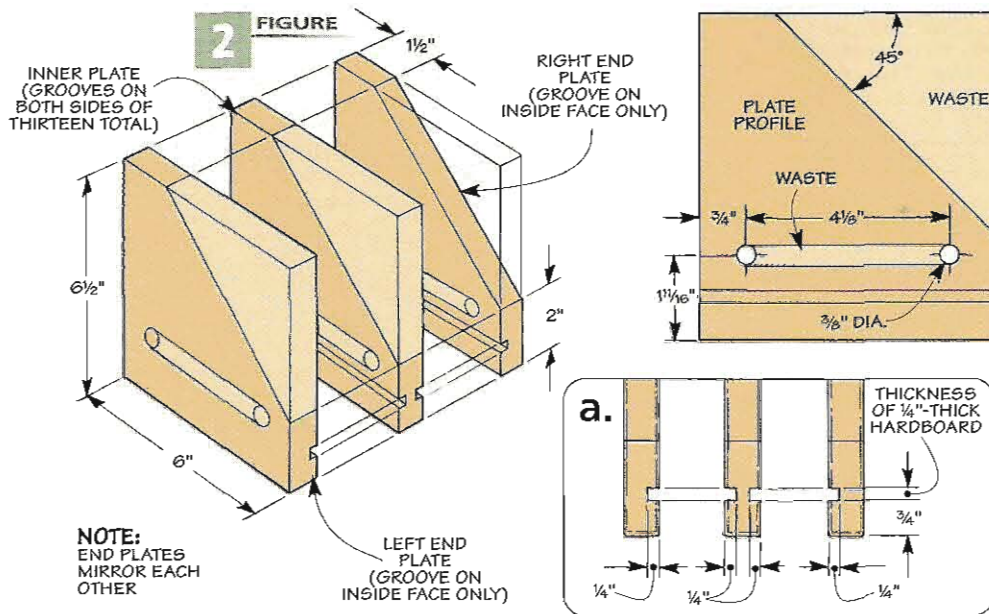



# Drill Press Table

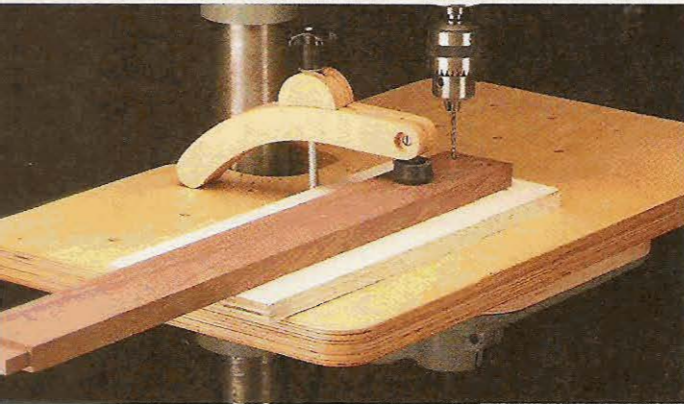

▲ **Drill Press Table.** This drill press table and hold-downs can be used with or without the V-block.

The drill press table is an important part of the V-block system. It makes the V-block easier to use, especially when it's combined with the hold-downs shown below. But the nice thing about this table is that you'll get plenty of use out of it even when you're not using the V-block.

The table (G) is made up of two layers of 3/4" plywood (Figure 7). I started by cutting the layers slightly oversized. Then after gluing them together, I trimmed the table to size.

The next step is to mount a series of T-nuts in the bottom of the table. These will be used to attach the hold-downs that will be added later. In

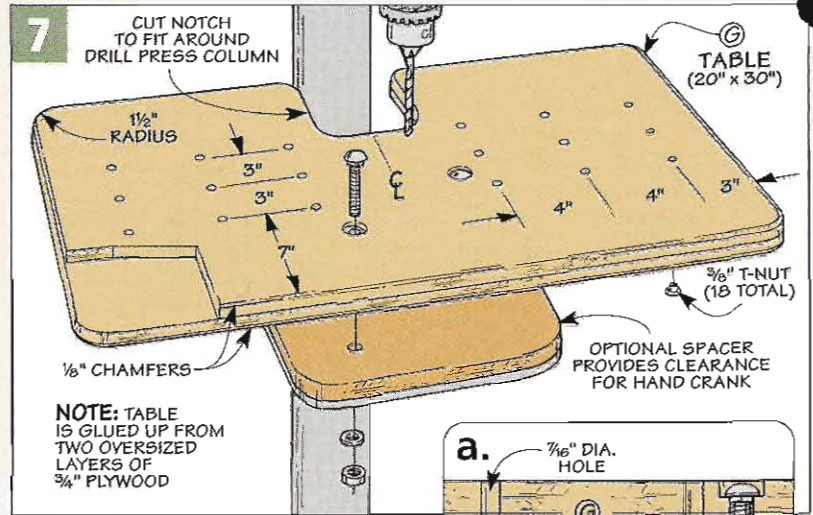

order to give you plenty of options when using the hold-downs, there are 18 T-nuts in all. Figure 7 shows the location for each one.

After the T-nuts are installed, the corners of the table can be rounded, and a notch can be cut out of the back to fit around the drill press column, as shown in Figure 7. Then the edges are chamfered.

**Mounting the Table** - I attached the table to my drill press with some carriage bolts, washers, and nuts

(Figure 7a). But once I had the table in place, I discovered a slight problem. On my drill press, there wasn't enough clearance at the back of the table to turn the hand crank that raises and lowers the table. So I had to add a spacer block between the table and the drill press. I just used a piece of 3/4" plywood.

## Hold-Downs

The hold-downs (H, I) are designed to work like an extra pair of hands — they hold the workpiece down firmly to the table while you operate the drill press. There are two parts to each hold-down: a long, boomerang-shaped body and a semi-circular clamp block that, along with a threaded rod and star knob, secures the hold-down to the table.

I made two pairs of hold-downs — a tall pair to use with the V-block and a short pair that can be used by themselves (see photo above). Each hold-down is glued up from two rectangular pieces of 3/4" thick plywood. The only difference is the size of the hold-downs (Figure 9).

If you take a look at Figure 8, you'll see that each hold-down has a long,

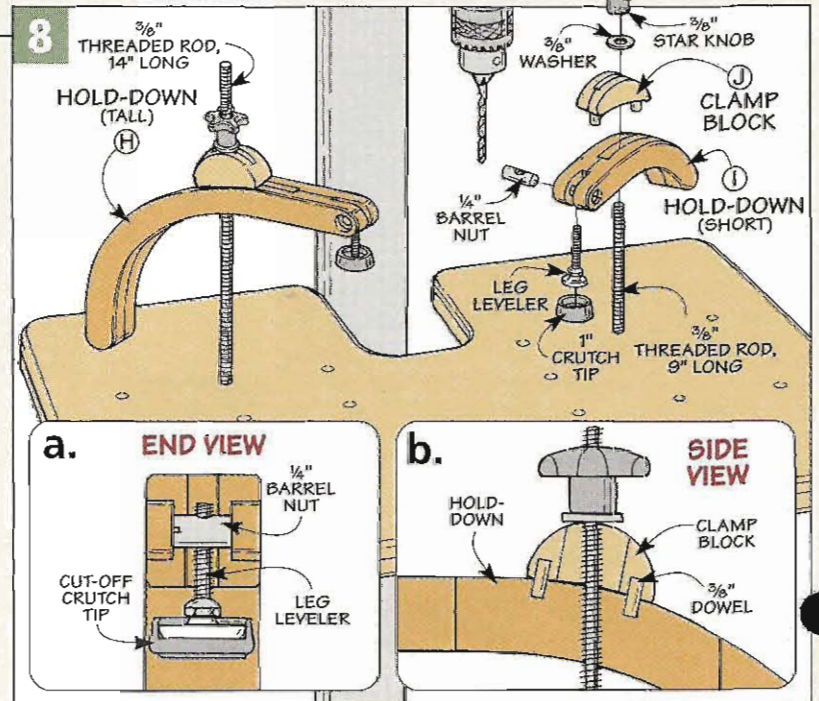

narrow slot in the middle where a threaded rod passes through. Instead of trying to make this slot after the hold-down is assembled, I made it before the blanks are glued together.

To do this, I simply cut a wide, shallow groove on the inside face of each blank (Figure 9). And I also cut a rabbet on the edge of each blank to create an opening for the hardware that is added later.

To keep the two blanks aligned during the glue-up process, I used a spacer block, as shown in Figure 10. After the glue is dry, you can lay out the profile and cut the hold-down to shape. A drum sanding attachment on the drill press will take care of any saw marks. Then you can rout a chamfer on all the edges.

**Clamp Pad** – The clamp pad on the end of each hold-down is made up of off-the-shelf hardware items — a barrel nut, a swiveling leg leveler, and a rubber “crutch tip” (see photo in margin). In order to accommodate the barrel nut, a hole is drilled through the end of the hold-down. This hole is counterbored from both sides to make the installation easier. Take a look at the detail in Figure 9.

**Clamp Block** – The little *clamp block* (*J*) that sits on top of the hold-down is also glued up from two pieces. A groove cut down the center of each piece creates an opening in

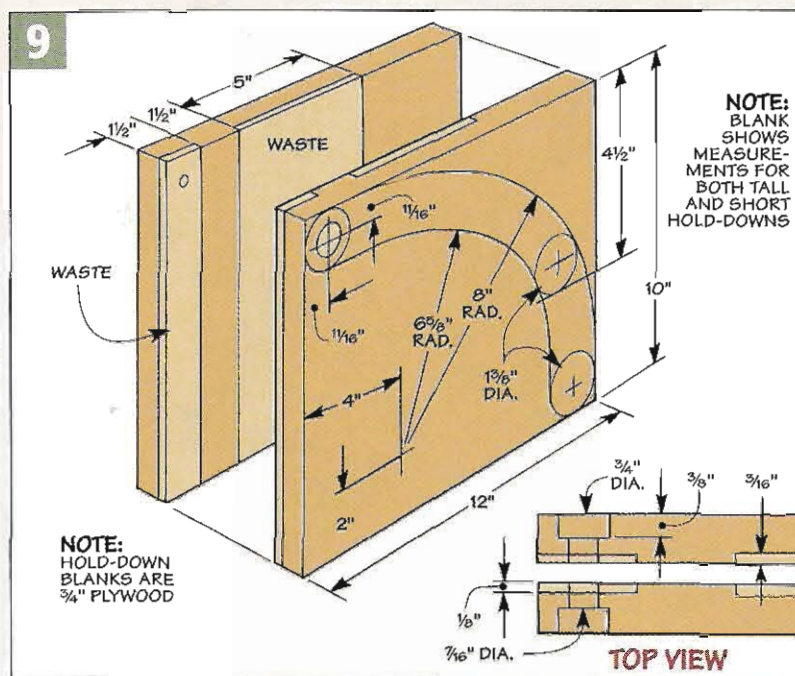

the center of the block, just like with the hold-downs. Because these pieces are so small, I started with a single, extra-long plywood blank, cut to width (Figure 11). I cut the groove down the center for the opening, and then cut the blank in half and glued the two pieces together.

After the glue is dry, you can lay out the profile of the clamp blocks and crosscut the strip into individual blocks. Before cutting the blocks to shape though, you'll need to drill a couple of holes in each block for a

pair of alignment pins that are added later (Figure 11). These pins will fit into the slot in the hold-down and help keep the two pieces aligned.

After cutting the blocks to shape and sanding and chamfering the edges, you can glue the alignment pins into the holes. These are nothing more than a couple of short lengths of wood dowel stock. Finally, each block and hold-down can be mounted to the table with a star knob, a washer, and a length of threaded rod.



▲ **Clamp Pad.** To make the clamp pad, thread a leg leveler into a barrel nut. Then cut off the end of a rubber crutch tip and slip it over the leg leveler.

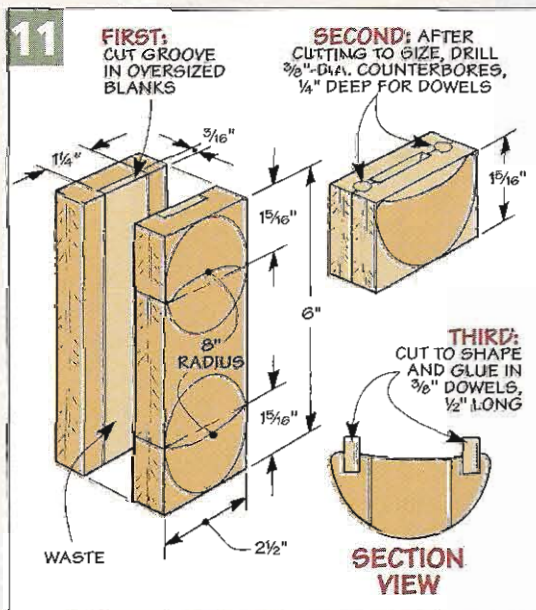
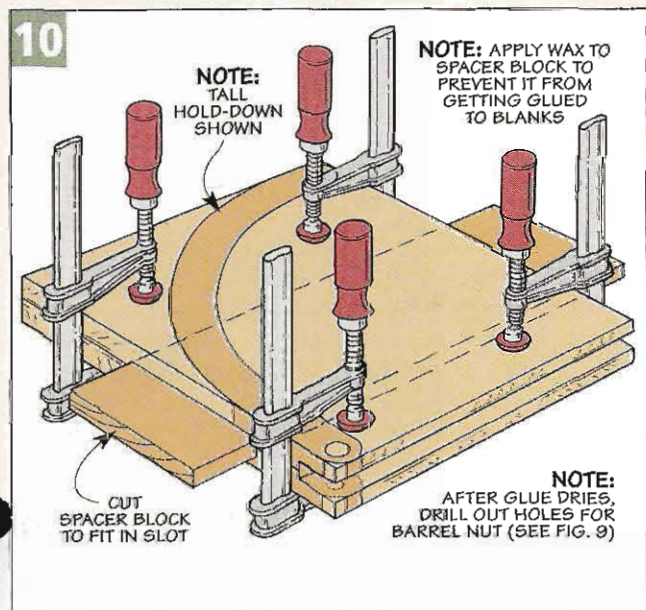



## Adjustable Shooting Board

**A** cat's whisker. That's the difference between a perfect-fitting miter and one that "almost" fits. But trying to shave such a small amount off the end of a workpiece with a table saw or compound miter saw is almost impossible. For a delicate procedure like this, a sharp hand plane works much better. The trouble is that it's difficult to hold the workpiece at an exact angle while planing the end. That's where a shooting board comes in.

A shooting board not only helps to steady the workpiece, it guides the plane at the same time. So you can take a paper-thin shaving off the end of a workpiece.

Most shooting boards are little more than a narrow, rabbeted board with a fixed block of wood to act as a stop. This shooting board is different in a couple of ways.

First, it has a pivoting stop block with automatic settings at 45° and 90°. But you can also adjust the stop block to any angle in between. Plus, the shooting board has sliding fences that can be adjusted to completely back up the workpiece and prevent tearout.

To help set up and use your shooting board, we've included a separate article that begins on page 16. It features some tips on getting the best results.

# Base

There's not much to the base of the shooting board. It's just a piece of medium-density fiberboard (MDF) with a cleat for clamping the jig in a bench vise. But the base serves an important purpose. A rabbet along the edge of the base guides the plane in a straight path as it trims the workpiece.

The base (A) starts out as a rectangular blank. To make it a little lighter and easier to handle, I trimmed off the back corners of the base, as shown in Figure 1 at right. Then I proceeded to cut the rabbet for the plane.

As you can see in Figure 2, cutting the rabbet is a two-step process. First, a kerf is cut in the base two inches from the edge (Figure 2a). Then the workpiece is placed on edge, and the rest of the waste is cut away (Figure 2b).

**Drill Hole** - Once the rabbet is cut, the next step is to drill a hole in the base for a pivot pin that will be added later. I did this on the drill press, like you see in Figure 3.

**Cut Groove** - Before you can add the cleat, you need to cut a groove in the bottom of the base. This groove will hold the cleat and keep it aligned during assembly. In Figure 4, you can see how I cut the groove on the table saw with a dado blade.

**Cleat** - The cleat is nothing more than a narrow strip of MDF. After knocking off the sharp corners of the cleat (B), it can be glued and screwed to the base. Then a chamfer is routed around the edges of the base. (Note: The rabbeted edge of the base is *not* chamfered.)

**Pivot Pin** - The last step to complete the base is to add a pivot pin for the adjustable stop that will be added later.

The pivot pin is just a piece of 1/4"-dia. steel rod. It gets cut to length (1 1/4") and is then epoxied into the hole that was drilled in the base in Figure 3. Once this is done, you're ready to start working on the stop and fences of the shooting board.

## 1 OVERVIEW

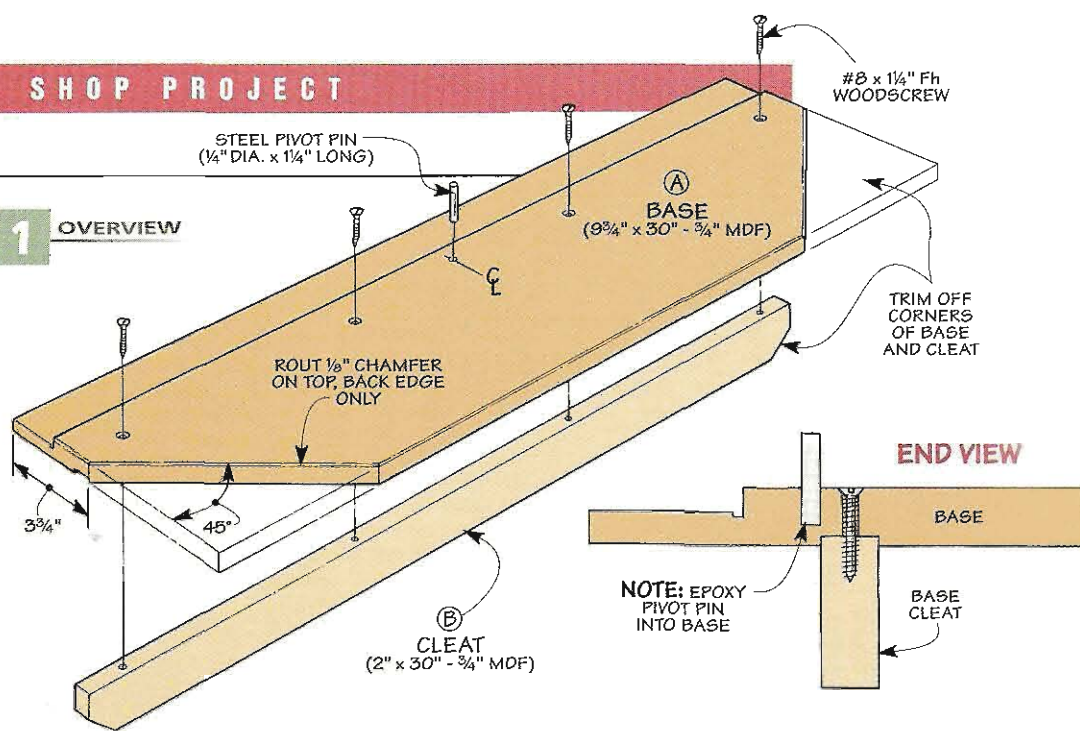

## 2

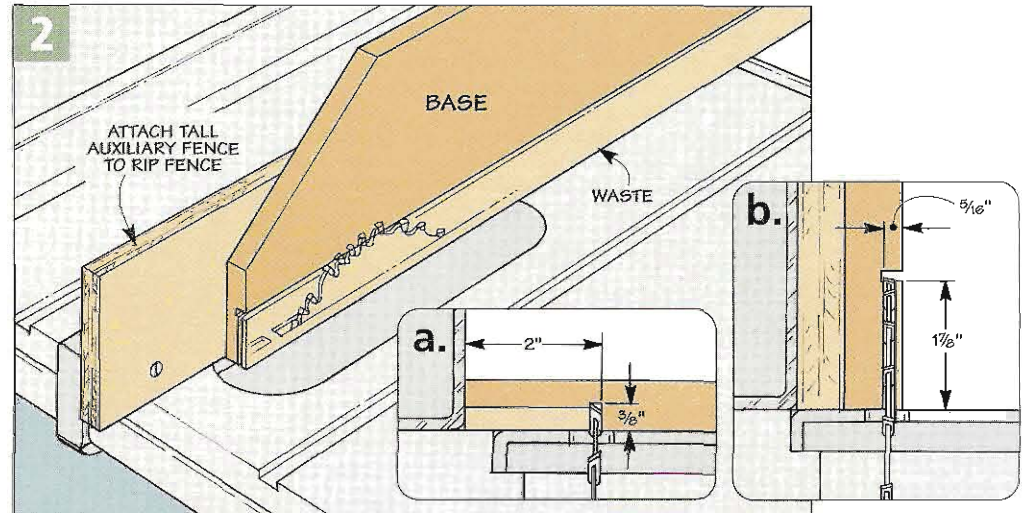

## 3

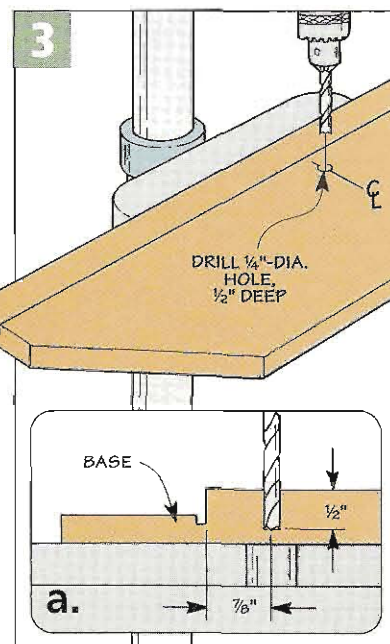

## 4

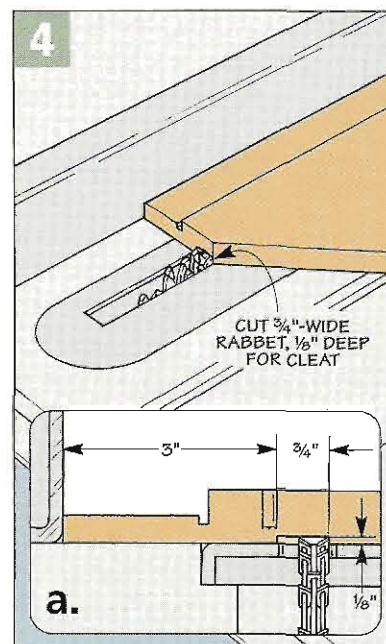

# Stop and Fences

The rabbet cut in the base of the shooting board guides the hand plane. But in order to hold the workpiece in place you need a stop block. On most shooting boards, this stop is just a block of wood that is glued or screwed to the base. But the stop on *this* shooting board is designed to pivot so it can be set up for miters of any angle.

The *stop block* (C) starts off as a square blank cut from MDF. It's important to make sure this blank is cut square so that you have a true, 90° corner.

Before cutting the blank to shape, I laid out and drilled all the holes. First, a couple of 1/4"-dia. holes for the pivot pin and locking pin are drilled, as you see in Figure 6. Then you can drill the holes for a pair of T-nuts. These holes are counterbored so the T-nuts will be flush with the bottom of the stop block when they are installed (Fig. 6b). These T-nuts will be used to hold the sliding fences that are added later.

After installing the T-nuts, the stop block can be cut to shape. I laid out the profile on the blank and then cut it to shape on a band saw, see Stop Block Detail below. But if you don't have a band saw, you could use a jig saw. After cutting the block to shape, the edges are sanded to remove any saw marks. And the top,

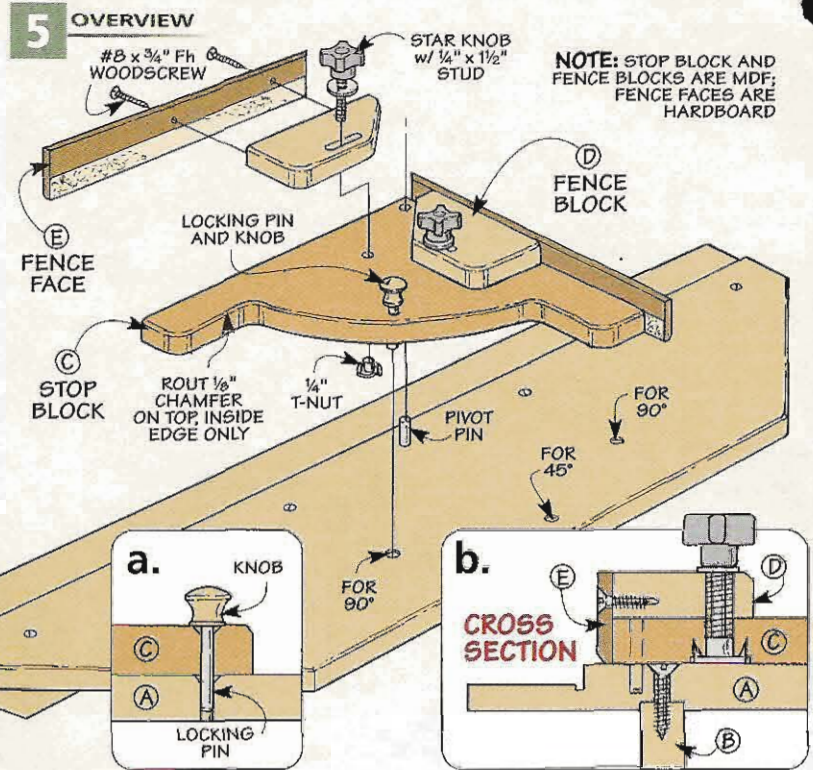

inside edge is chamfered (Figure 6).

**Sliding Fences** - In order to back up your workpiece when "shooting" a miter, a pair of sliding fences are attached to the stop. These fences can be adjusted in or out to provide maximum support for your workpiece.

Each fence is made up of a fence block and a fence face (Figure 7). The *fence blocks* (D) are cut to shape from 3/4" MDF. After the edges

are sanded smooth, a slot is cut in each block for a knob with a threaded stud. I made these slots by drilling a couple of holes to establish the ends of the slot then cutting out the waste in between with a jig saw.

After the slots are cut, you can chamfer the top edges of each block. Just don't chamfer the front (long) edge. This edge is left square since the fence face will be added to it later. Also, when you are chamfering the

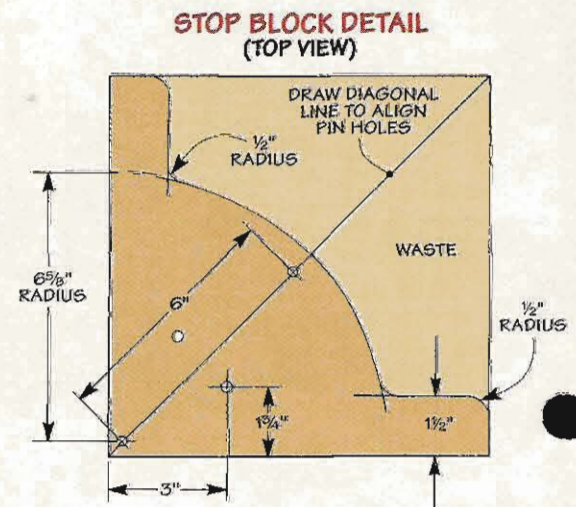
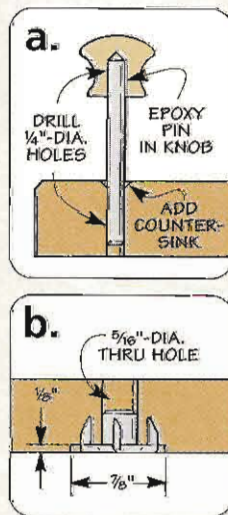
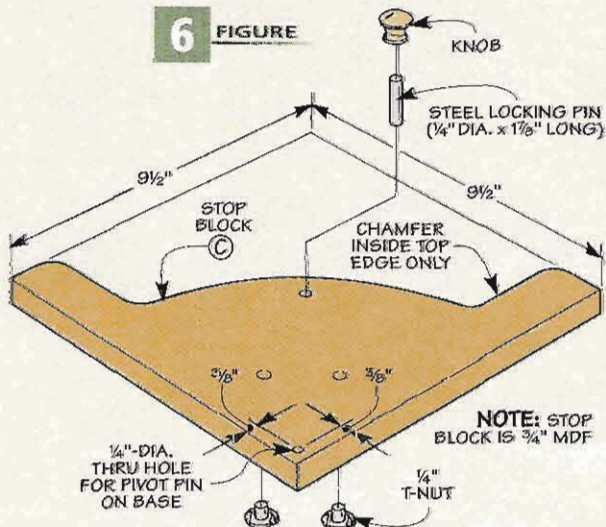

edges, keep in mind that you will need a left-hand fence block and a right-hand fence block.

**Fence Faces** – The *fence faces* (E) are just narrow strips of 1/4" hardboard, mitered on one end. Each fence face is chamfered slightly on the bottom edge to create a relief. After the fence faces are made, they get screwed to the fence blocks. I didn't use any glue here so that I could replace the faces later if they get chewed up.

**Fence Hardware** – The sliding fences are mounted to the stop block with star knobs and washers. The knobs have threaded studs that screw into the T-nuts mounted in the stop (Figures 5b and 7).

Once the fences are added to the stop, the next step is to drill a few holes in the base of the shooting board for a locking pin. This will allow you to automatically position the stop at 45° or 90°.

It's important that the holes for the locking pin are drilled accurately. To do this, I placed the stop over the pivot pin in the base of the shooting board. Then I used a combination square to set the stop at a 45° angle to the rabbeted edge of the base, as you see in Step 1 below. With the stop clamped securely in place, I drilled a 1/4"-dia. hole in the base, using the hole in the stop as a guide.

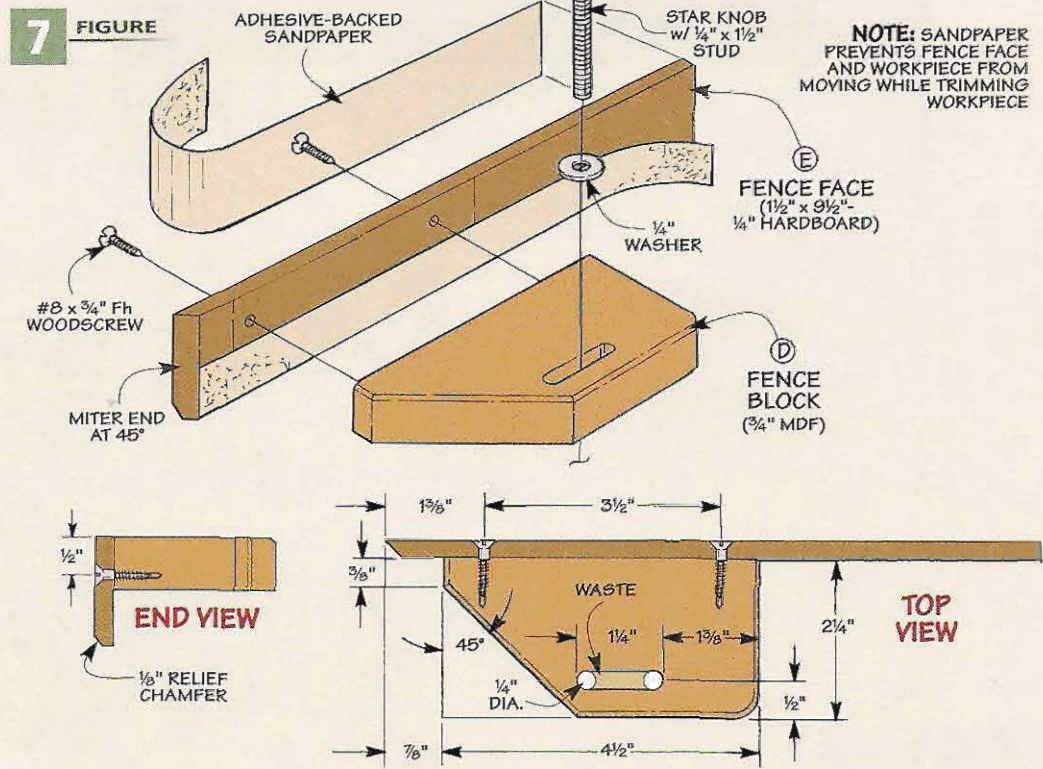

To drill the second hole, I repositioned the stop at 90°, see Step 2 below. Then I swung the stop around so the opposite fence was perpendicular to the edge and drilled a third hole. After all three holes are drilled, you can pivot the stop out of the way and countersink the holes in the base. This will make it easier for the locking pin to slip into each hole when you are using the shooting board.

**Locking Pin** – Like the pivot pin, the locking pin is also cut from a piece of 1/4"-dia. steel rod. But a wood knob is epoxied to the end of the locking pin to make it easier to remove (Figure 6a). Finally, I added some adhesive-backed sandpaper to both sides of the fence faces (Figure 7). For more information on setting up and using the shooting board, see the article on page 16.

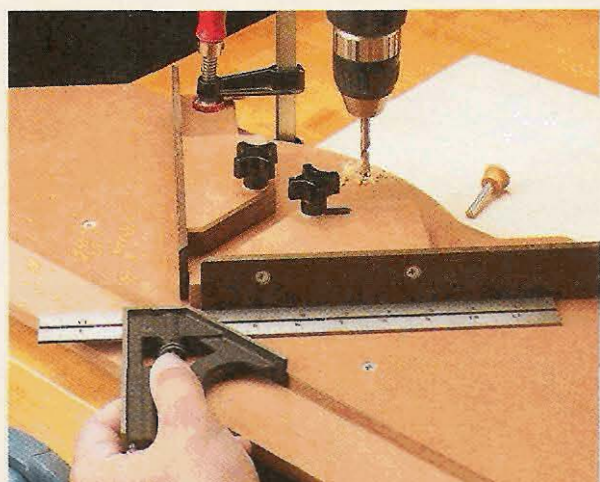

**1** To drill the holes in the base for the locking pin, use a square to position the stop block. With the stop block clamped in place, drill a hole in the base, using the hole in the stop block as a guide.

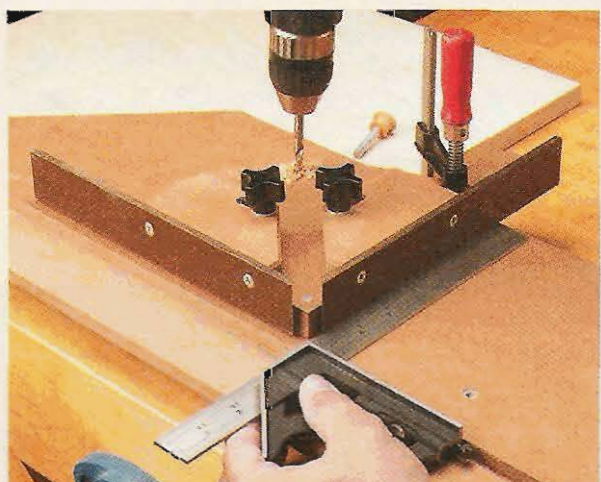

**2** To drill the two holes for the right angle settings, reposition the stop so it is square to the front edge. Countersink the holes after drilling them to make it easier to insert the locking pin.

# Setting Up & Using Your Shooting Board

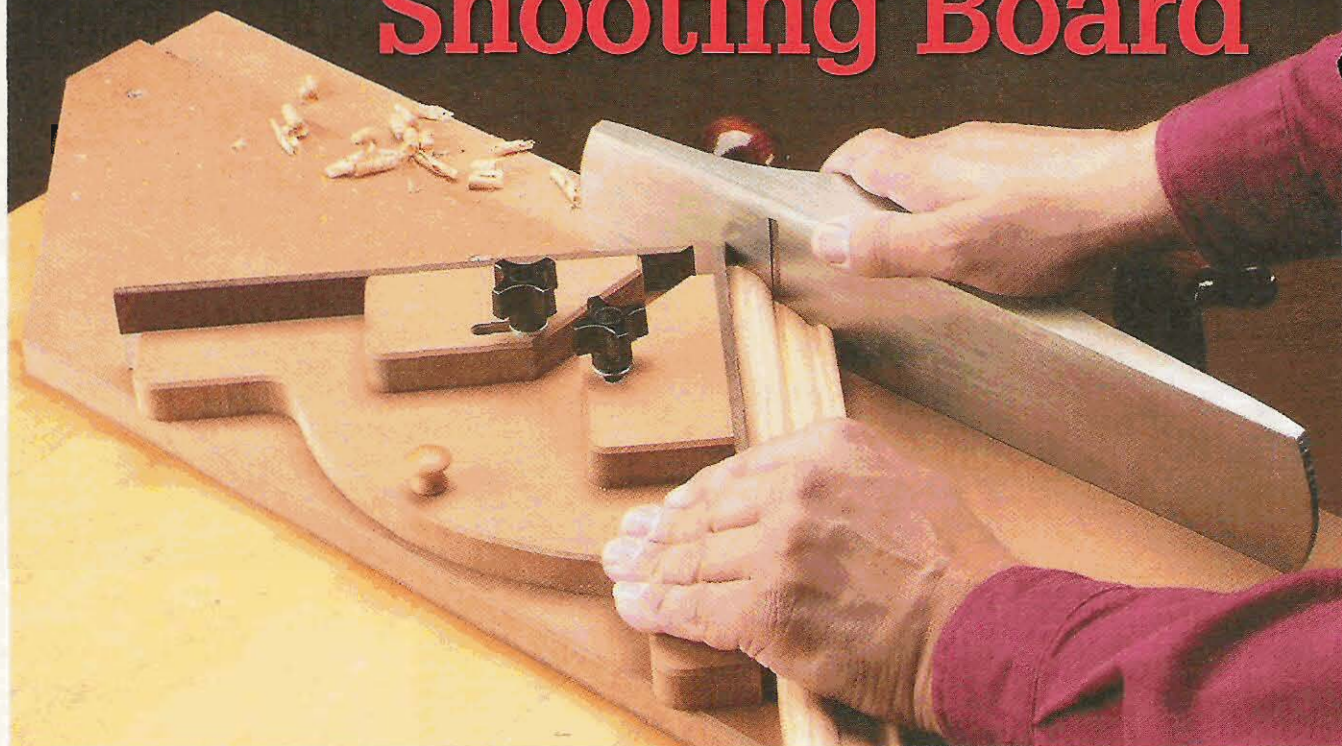

**I**n theory, using a shooting board is pretty simple. You just hold the workpiece with one hand and slide the plane forward with the other hand. The shooting board guides the plane to trim the end of the workpiece. But there's a bit more to it than that. Getting good results takes a little skill and technique. And there are a few tips that can also help.

**Check Your Plane** - Before using your shooting board, you might want to spend a minute to give your hand plane a quick once-over. First, check to make sure that the blade is sharp. Cutting through the end grain of a miter is tough work, so having a sharp blade is a must.

Second, you should check to see that the sides of the plane are square with the bottom, see photo at left. If the bottom and sides are just a little out of square, you can compensate for this by adjusting the blade sideways until it is square with the side. (Use the lateral adjustment lever just underneath the blade to make this adjustment.)

One other thing. You can use any size bench plane with this shooting

board. But I like to use a larger plane, like a #5 or a #7. When you start pushing the plane forward on the shooting board, the extra mass of the heavier plane helps to keep it moving for a smoother cut.

**Setup** - Once your plane is ready, the next step is to clamp the shooting board in a vise (or between two bench dogs, if your shooting board doesn't have a cleat on the bottom). The important thing is that it's held securely so it won't move.



▲ **Check for Square.** To get good results, the sides of your plane need to be square with the sole.

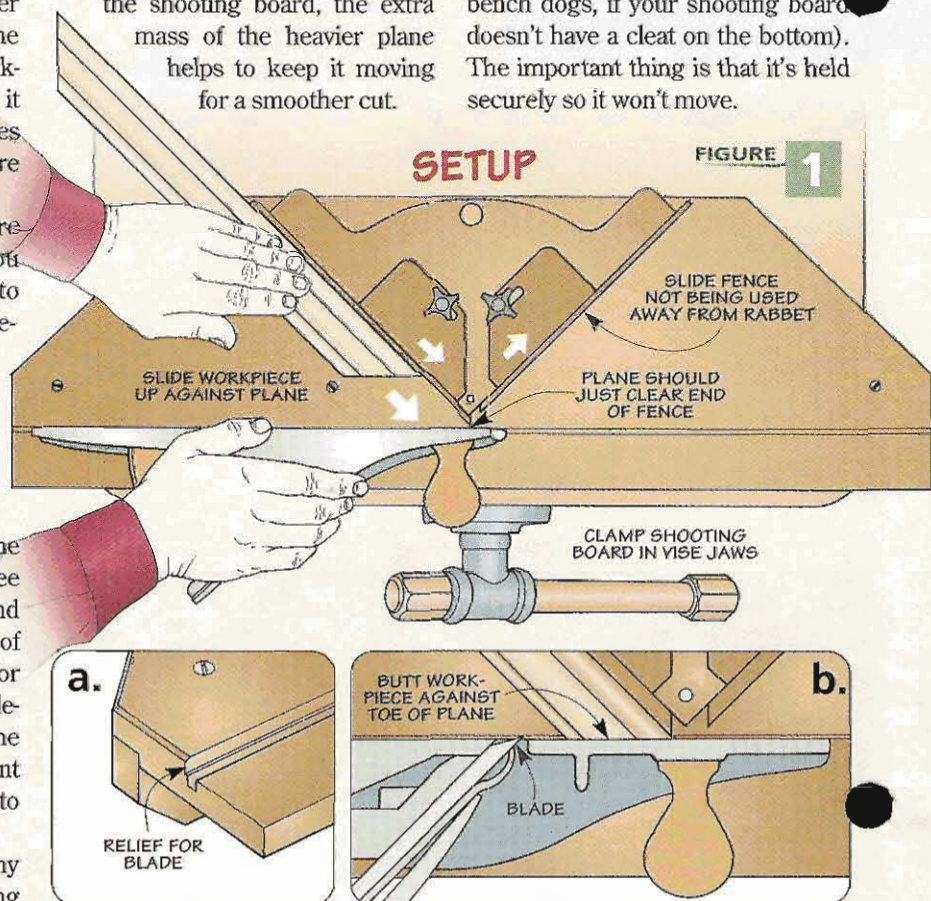

USE

FIGURE 2

Now position the stop block and make sure that the locking pin is fully seated to lock it in place. Then adjust the sliding fence so that the end of the fence face is about 1/32" behind the edge of the rabbet that the plane will ride in. The other fence (the one that isn't in use) should be slid back so it is well out of the way.

**Relief** – The very first time you use the shooting board, the blade of the plane will cut a small, shallow relief along the edge of the rabbet, as you can see in Figure 1a. The relief is necessary to create clearance for the plane blade. Before setting a workpiece on the shooting board, set your plane to take a fine shaving and then take a pass along the entire length of the rabbet. Now you're ready to start planing an actual workpiece.

**Shooting a Miter** – To use the shooting board, hold the hand plane tight against the edge of the rabbet. The toe of the plane should be just past the end of the fence, like you see in Figure 1. Then slide the workpiece along the fence until it butts up against the bottom of the plane (Figure 1b).

Now while holding the workpiece firmly in place, slide the plane forward to take a thin, wispy shaving off the end of the workpiece (Figure 2). Before making the next pass, just draw the plane back and slide the workpiece forward until it contacts

the toe of the plane again. Take as many passes as necessary to trim the workpiece to its final size.

Try to make each cut in one continuous sweep, rather than hacking your way through the workpiece in short, choppy strokes. (Here's where the weight and mass of the plane come into play.)

One trick I've learned is that it helps to wet the end grain with a damp cloth (see photo in margin) before trimming the end. This helps the blade slice through the wood a little easier, giving you a much cleaner cut.

**Different Angles** – One of the nice features about our shooting board is that it can be used for more than just trimming 45° miters. For example, if you need to shave a hair off the square end of a workpiece, all you have to do is move the stop

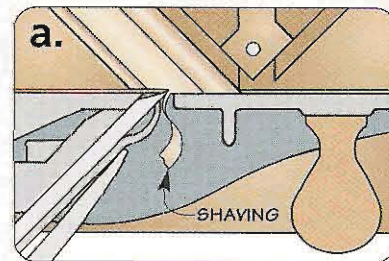

▲ **Smooth Cutting.** Dampening the end grain with a wet cloth makes it easier for the plane to slice through the wood without tearing the fibers.

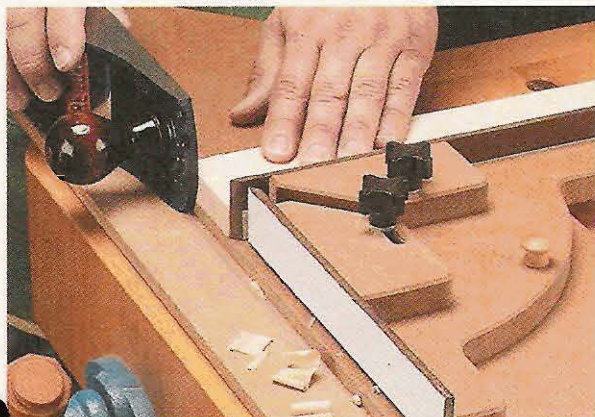

▲ **Shooting End Grain.** With the stop block set perpendicular to the edge of the shooting board, you can shave a hair off the end of a workpiece.

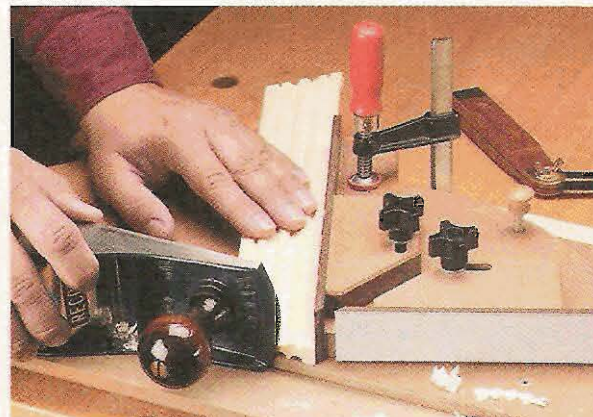

▲ **Other Angles.** By disengaging the locking pin and securing the stop block with a clamp, you can use the shooting board to trim miters at any angle.

# Twin-Screw Heavy-Duty Workbench

*With its solid construction and two vises, there isn't a task this classic workbench can't handle.*

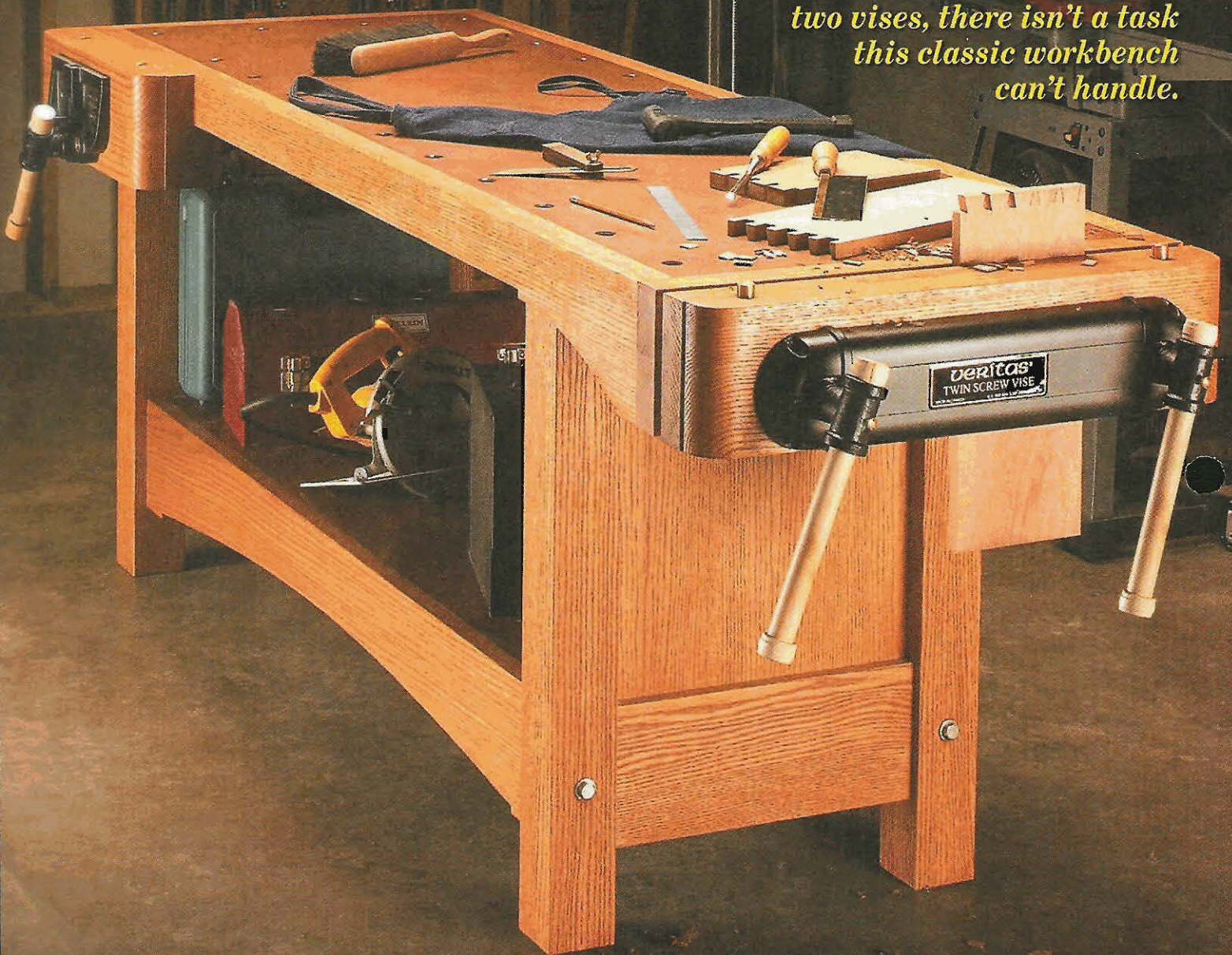

**A** great workbench needs to have a couple important qualities. First, it has to be solidly built. You don't want it sliding or moving around as you work. Second, it has to offer options for clamping a workpiece securely in place. This way, you don't have to worry about the workpiece shifting as you rout, sand, or cut. The workbench shown above meets all these requirements — and more.

**Solid Construction** — It's built with red oak and medium-density fiberboard (MDF) for strength and sta-

bility. And the knock-down hardware used to assemble the base allows you "tighten" it due to changes in humidity (or disassemble it if you ever need to move it).

**Vises** — But a solid bench isn't of much use if you can't hold a workpiece securely. So this bench incorporates a front vise (see detail 'a' on opposite page) and a unique twin-screw vise (see detail 'b'). Along with the dog holes in the top, they provide an unlimited number of clamping options. This just might be the last workbench you'll ever need.

**EXPLODED VIEW**  
OVERALL DIMENSIONS:  
87"L x 34 1/4"D x 35"H

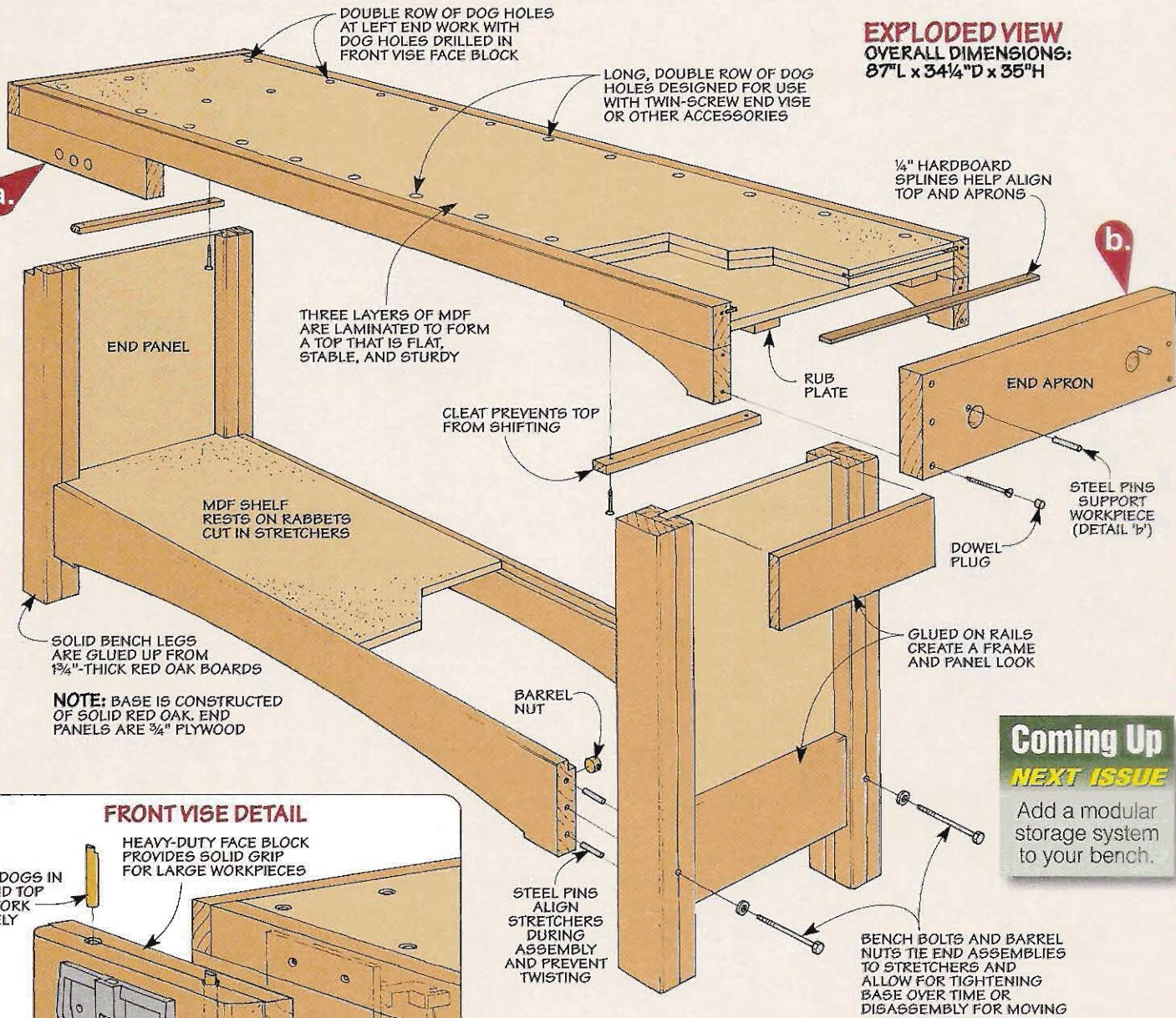

**Coming Up**  
**NEXT ISSUE**  
Add a modular storage system to your bench.

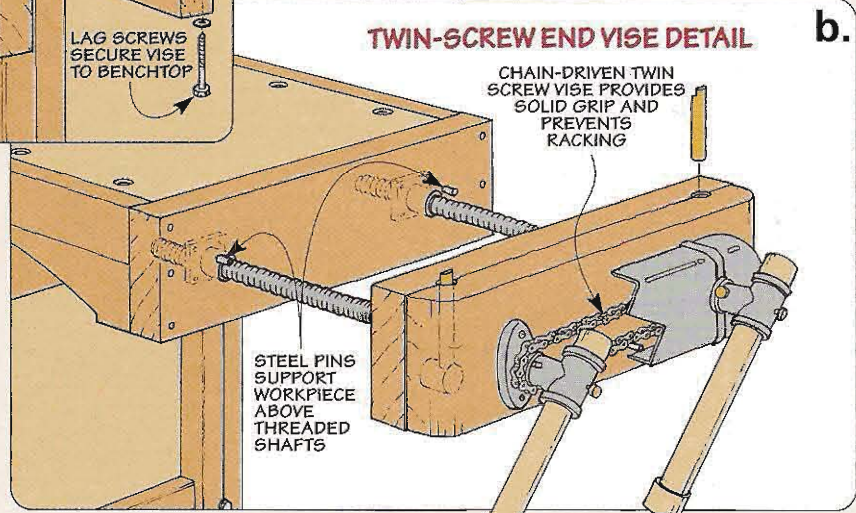
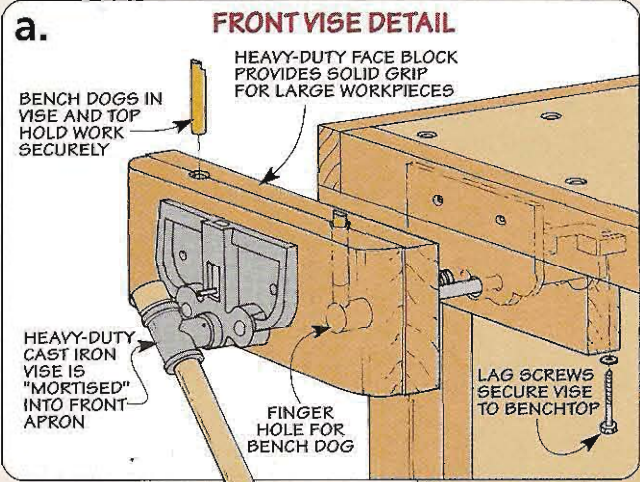

**ShopNotes** To download a free Cutting Diagram for the Heavy-Duty Workbench, go to: [www.shopnotes.com](http://www.shopnotes.com)

# Base

## 1 OVERVIEW

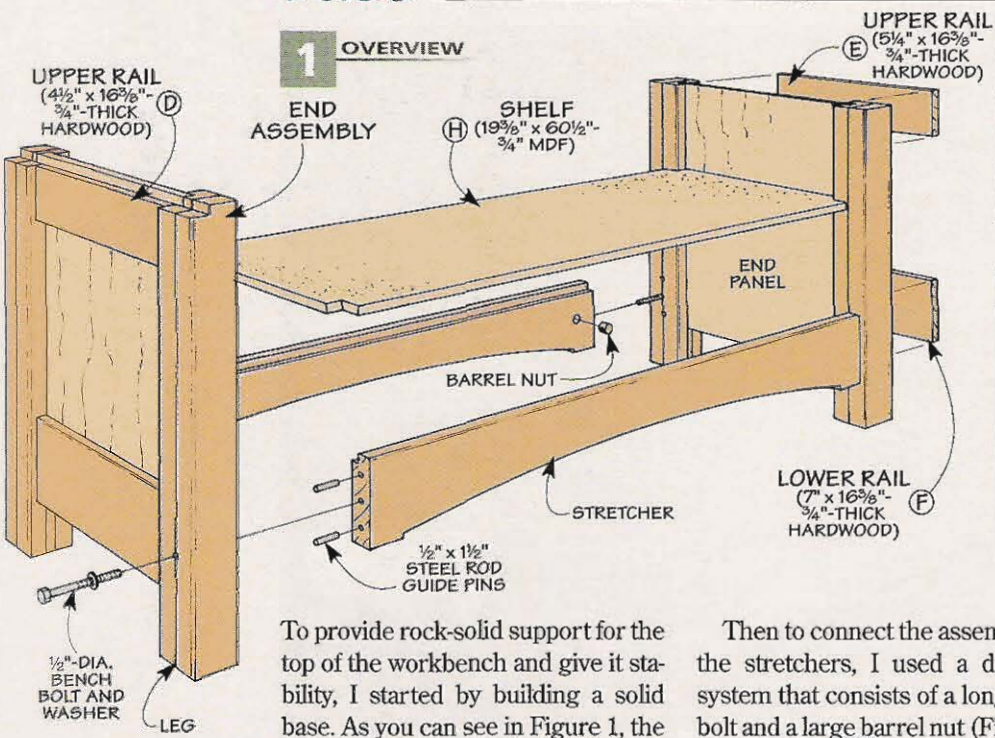

To provide rock-solid support for the top of the workbench and give it stability, I started by building a solid base. As you can see in Figure 1, the base consists of two *end assemblies* connected by a pair of *stretchers*.

**Joinery** – One of the first things you'll notice in Figure 2 is there isn't any tricky joinery like large mortise and tenons to deal with.

Instead, the end assemblies are formed by cutting a simple groove in each leg and then joining them with a 3/4" plywood panel. This creates a strong assembly that resists racking and twisting.

## 2 FIGURE

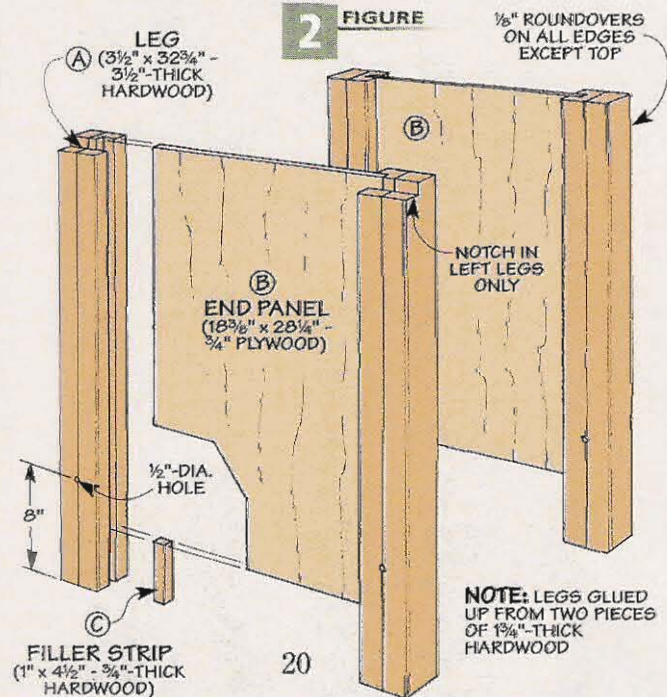

Then to connect the assemblies to the stretchers, I used a draw-bolt system that consists of a long bench bolt and a large barrel nut (Figure 1b and margin photo on opposite page). Although it does allow you to take the base apart, the bigger benefit is you can "snug up" the base due to changes in humidity.

**End Assembly** – Each end assembly starts out as a pair of 3 1/2"-square legs (A), like you see in Figure 2. I formed each leg by gluing up two pieces of 1 3/4"-thick red oak.

It's best to rip these pieces slightly wider than necessary. This way, you don't have to worry about aligning the edges perfectly while gluing them up. Then after the glue dries, simply square up the legs and cut them to final length.

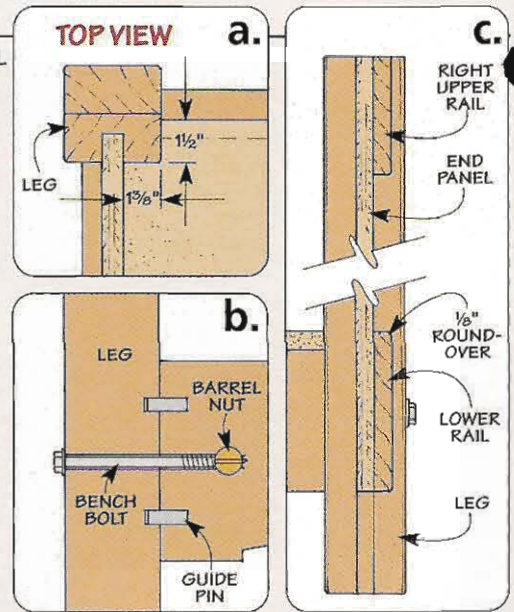

**Grooves** – Now you can turn your attention to the groove in each leg (Figure 3). Since this groove accepts the 3/4" plywood *end panel* (B), you can cut the panel to final size (Figure 2) and use it to check the fit of the groove (Figure 3a).

Although the legs are identical in size, there is one small difference. The top *outside edge* of the *left legs* are notched to accept the top, as illustrated in Figure 3b.

**Assembly Holes** – As I mentioned before, the base is held together by a draw bolt system. To ensure the hole for each bolt is located accurately, it's best to drill the holes now on the drill press (Figure 2). Then, I routed a small (1/8") roundover on each edge of each leg (except the top ends).

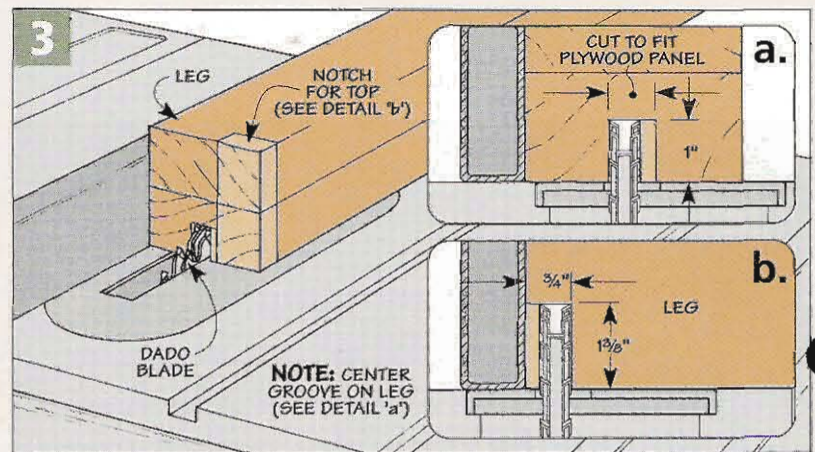

**Assemble Ends** – At this point, you can glue up each end assembly, making sure the panels are flush with the top of each leg (Figure 2). Then, to fill in the groove just below the end panel in each leg, I glued in a hardwood *filler strip* (C).

To give the end assemblies a “frame and panel” look, I added “rails” to each assembly (Figures 1 and 1c). The *upper rails* (D, E) are slightly different in width (to account for the notch in the left legs), while the *lower rails* (F) are identical. After rounding the *outside* edges, they’re simply glued in place.

**Stretchers** – At this point, you can set the end assemblies aside and concentrate on the stretchers. Each *stretcher* (G) starts out as a 1 3/4"-thick piece of hardwood cut to final length and width (Figure 4).

To provide a decorative cutout, I cut a gentle arc on each stretcher that ends in a small “shoulder” near the end, like you see in Figure 4. Note: I used a long strip of 1/8" hardboard to lay out the arc.

Once the arc was complete, I installed a dado blade in my table saw and cut a rabbet along the top

4 FIGURE

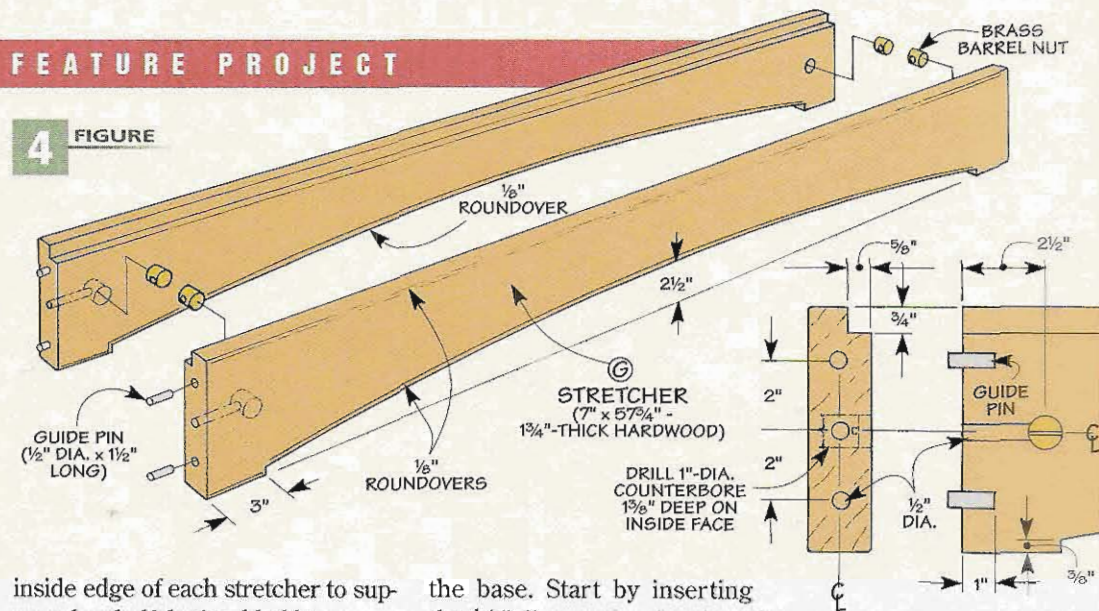

inside edge of each stretcher to support the shelf that’s added later.

Here again, I eased the upper and lower edges of the stretcher (except the inside edge of the rabbet).

**Draw Bolt Holes** – Now you’re ready to drill the holes for the draw-bolt system (Figure 4). I started by drilling a deep counterbore near the end of each stretcher on the *inside* face for the brass barrel nut (Figure 4).

Then to ensure the holes for the draw-bolt system mated perfectly with the holes in the legs, I used the drilling guide shown below.

**Assembly** – With the pins installed, you’re ready to assemble

the base. Start by inserting the 1/2"-dia. steel rod guide pins into the ends of each stretcher. These pins keep the stretchers aligned during assembly and prevent them from twisting.

After slipping the brass nut into the counterbore in each stretcher, mate the stretchers with the end assemblies and then tighten each bench bolt to pull the stretchers firmly against the legs.

**Shelf** – Finally, you can cut a *shelf* (H) to size so it rests in the rabbets on the top of the stretchers. To fit the shelf around the legs, you’ll need to notch each corner (Figure 1a).

▲ **Bench Bolts & Barrel Nuts.** A set of four bench bolts and barrel nuts makes it easy to assemble the base of the workbench. Refer to page 35 for sources.

Drilling Guide

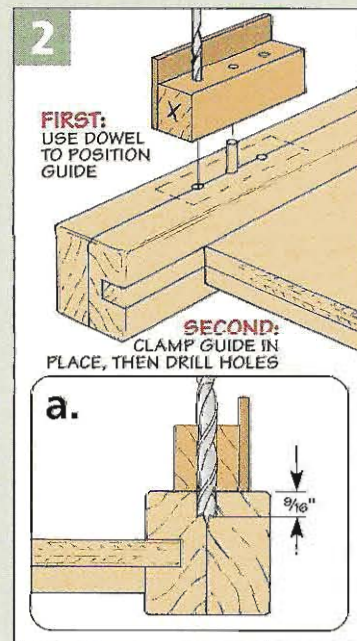
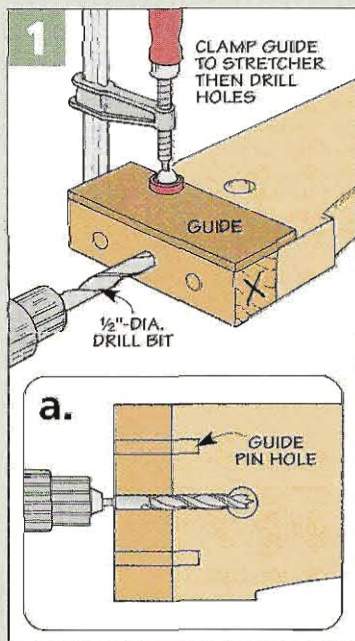

To ensure the holes for the guide pins and assembly bolt line up perfectly, I made the drilling guide shown below.

**Guide** – The guide is a 1 3/4"-square hardwood block cut to match the width of the stretcher. To make sure the holes were straight and true, I drilled them on the drill press. Then I attached a hardboard clamping plate to the side of the guide.

**Drill Holes** – To complete the holes in the stretcher, just clamp the guide in place and drill (Figure 1). Note: An ‘X’ on the “bottom” of the guide helps orient it identically on the stretchers and the legs.

**Leg Holes** – Since the bolt hole in the leg is already drilled, you can use the guide to locate and drill the two guide pin holes in the leg (Figure 2). Just slip a dowel in the center hole, align the guide parallel to the edge of the leg, clamp it in place, and then drill.

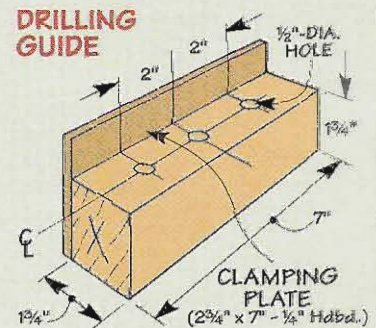

Top

5 OVERVIEW

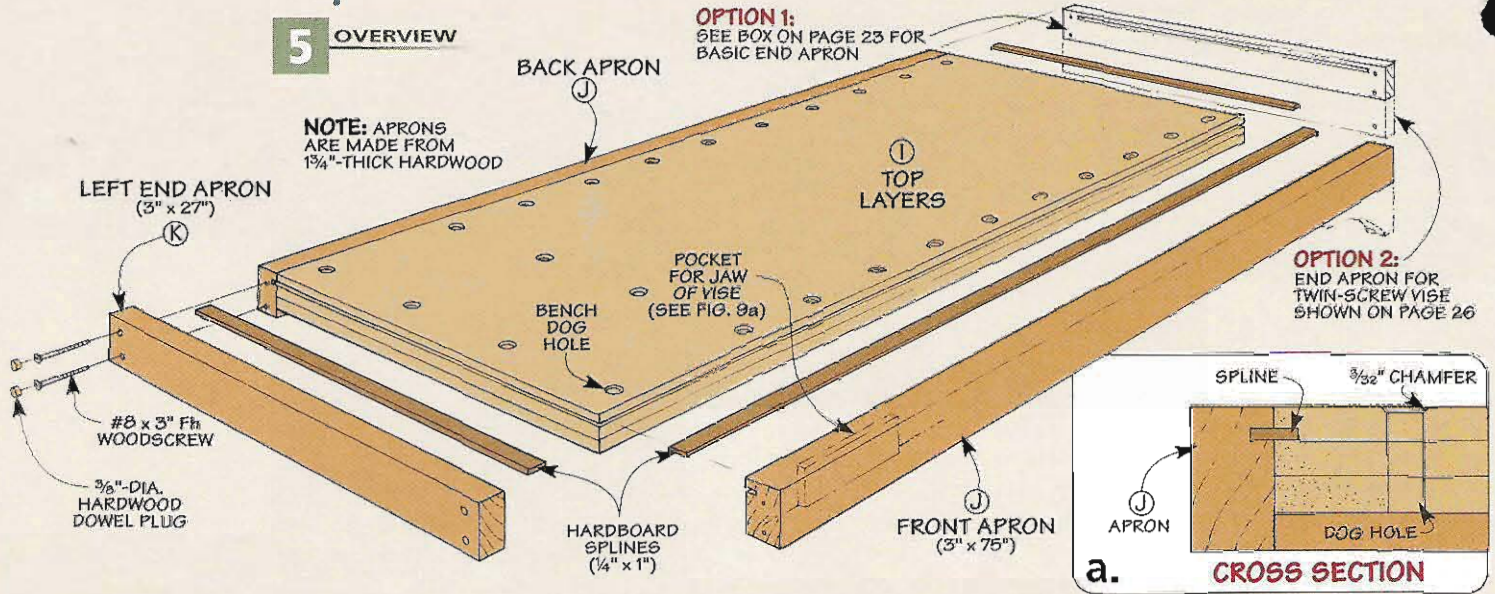

The top of a workbench sees pretty hard use, so it needs to be strong and sturdy. But just as important, it needs to be flat. I rely on the top of my workbench as a reference for all sorts of assembly chores.

I decided to use MDF (medium-density fiberboard) for the top of my workbench. It's heavy, stable, and very flat. And compared to a top made from solid wood, it's quite a bit less expensive.

**Built-Up Top** – To make the top thick enough for mounting a vise and holding bench dogs and other clamping accessories, the top is built up out of three separate layers, as

you can see in Figure 6. (For more on the accessories, refer to Sources on page 35). Then later it will be wrapped with hardwood aprons.

To make the top, I started by cutting all three *top layers* (I) to finished size. The problem is gluing all three layers together so all the edges stay perfectly flush.

To do this, I used screws to keep everything aligned and act as “clamps” while the glue dried. I started by clamping two of the layers together so the edges were flush. Then I pre-drilled a few holes for the screws. The only thing that's important here is to be sure to keep the

screws away from where you'll be drilling the dog holes. (I penciled in the location of the dog holes just to be sure.)

Once that's complete, you can separate the two layers and spread on some glue. I used a slow-set glue and spread it on the top layer with a 3" paint roller. Then just “clamp” the two layers together with the screws. Adding the third layer is just a matter of repeating the process.

**Dog Holes** – With the top glued up, you're ready to add the 3/4"-dia. dog holes. As you can see in Figure 5, there's a single row along the front and back edges (for use with a twin-

6 FIGURE

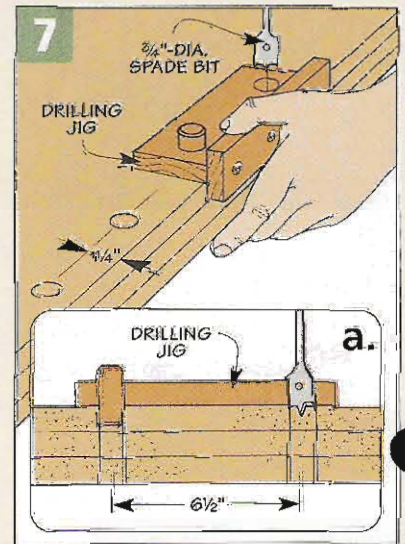
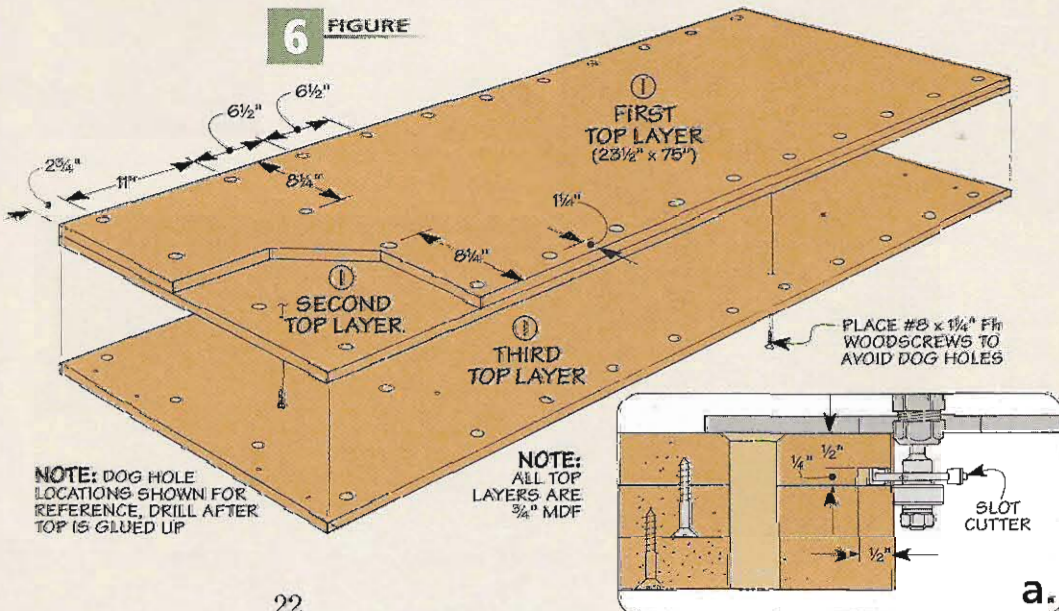

screw vise or other accessories) and a double row at the end (for use with the front vise).

For the double row of dog holes at the left end of the bench, I carefully laid out and drilled each one individually. Then to keep the hole spacing consistent on the two long edges (as well as to guide the drill bit straight), I made a simple indexing jig, as shown in Figure 7.

Finally, to soften the inside edge of each dog hole, I routed a small ( $\frac{3}{32}$ " chamfer (Figure 5a).

**Aprons** – With the dog holes complete, you can turn your attention to concealing and protecting the edges of the MDF. To do this, I wrapped the top with  $1\frac{3}{4}$ "-thick hardwood aprons.

I started by cutting the *front/back aprons (J)* to length so they were flush with the ends of the top, like you see in Figure 5. Then I cut a single *end apron (K)* for the left side of the bench. It's the same width as the other aprons, but it's cut to length so it's flush with the outside faces of the front/back aprons.

For now I left the right end of the bench open. Later you'll make a wider apron (and drill a few holes) to accommodate the twin-screw end vise (refer to page 26).

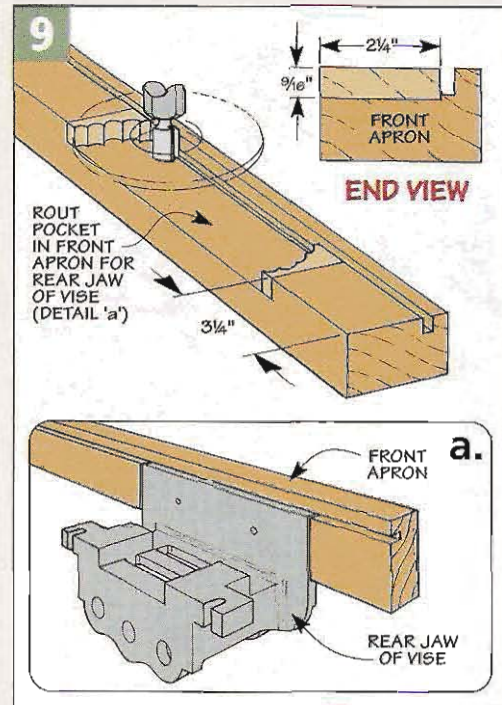
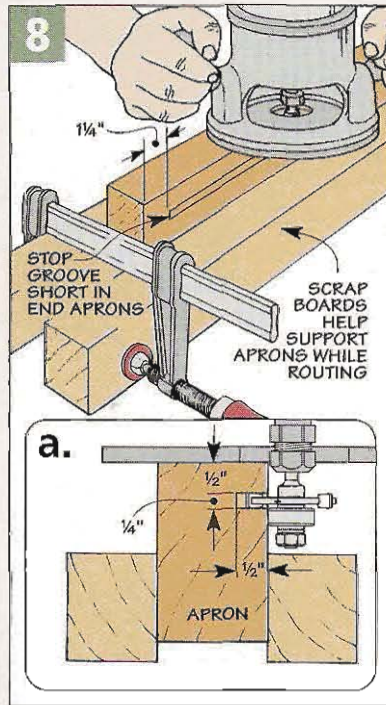

But if you don't plan on installing the twin-screw vise, simply make a second end apron as shown in the No End Vise box below.

**Groove** – After cutting the aprons to size, you can turn your attention to the grooves that run around the top of the bench and along the inside face of each apron, as you can see in Figure 5. These grooves accept hardboard splines that help align the

aprons with the top of the bench while they're glued in place.

A router and a slot cutter is all you need to make the grooves in both the top and aprons (Figures 6a and 8a). But you'll want to note that the grooves stop short of the exposed ends (Figure 8).

Another thing to note is that the front apron has a small "pocket" routed in the back face to accommodate the rear jaw of the front vise (Figures 5, 9, and 9a). The size of this pocket will depend upon the vise you use. I made mine deep enough for the thickness of the jaw and slightly oversized in width and length ( $\frac{1}{16}$ ").

**Splines** – With the grooves and vise pocket complete, you can glue the aprons to the top using splines cut into strips from a sheet of  $\frac{1}{4}$ " hardboard. Clamping the front and back aprons isn't a problem. But clamping across the length of the bench is a challenge. To see how I did this, take a look at the margin.

After drilling some counterbored holes, I screwed the end apron in place and then plugged the holes with some dowel plugs (Figure 5).

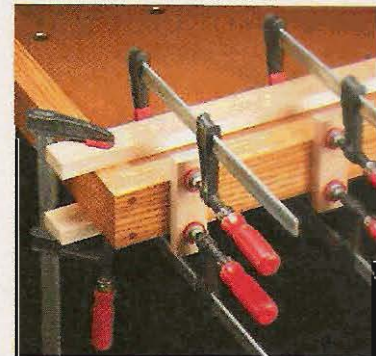

▲ "Stretching" Your Clamps. A couple of cleats attached to the top of the bench allow you to clamp the end apron in place.

## No End Vise Option

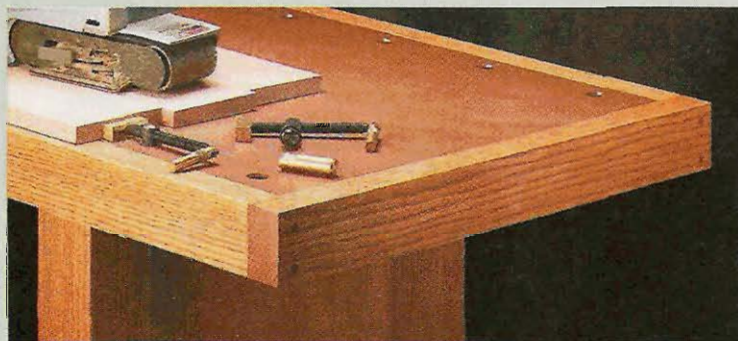

If you'd rather not add the twin-screw vise, the addition of the aprons is much simpler, as you can see in the photo above.

All you'll need to do is make and install a second apron just

like the one at the left end.

Even without the twin-screw vise, you can still make use of all the dog holes using the bench dogs and accessories shown above. (Refer to Sources on page 35.)

# Front Vise

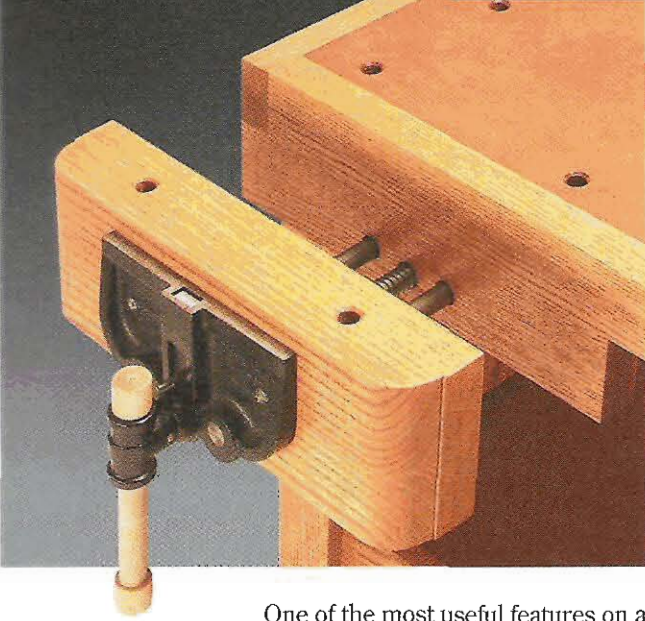

One of the most useful features on a workbench is a heavy-duty front vise. And the quick-action front vise shown above is no exception.

But what's really nice about this vise is installing it is only a three-step process. And since the first step of cutting the pocket is already complete, there are only two steps left: attaching the rear jaw to the bench and then adding a wood face block to the front jaw (Figures 10 and 10a).

But why go to all this trouble when you could simply bolt the vise to the apron and add a couple wood pads to each face of the vise?

I had a couple reasons. First, placing the rear jaw in a pocket creates a large, smooth face the length of the bench for clamping. And adding a thick face block with dog holes allows you to securely clamp a variety of wider workpieces using bench dogs in the holes in the top.

**The Vise** - To install the vise, you'll need to take it apart first. But

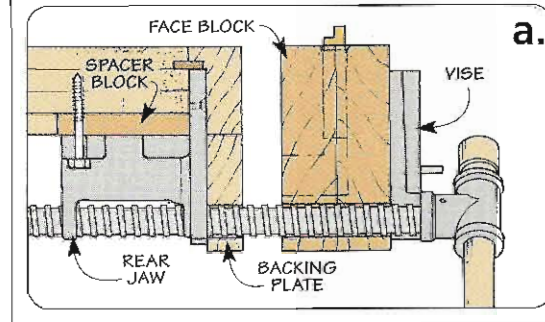
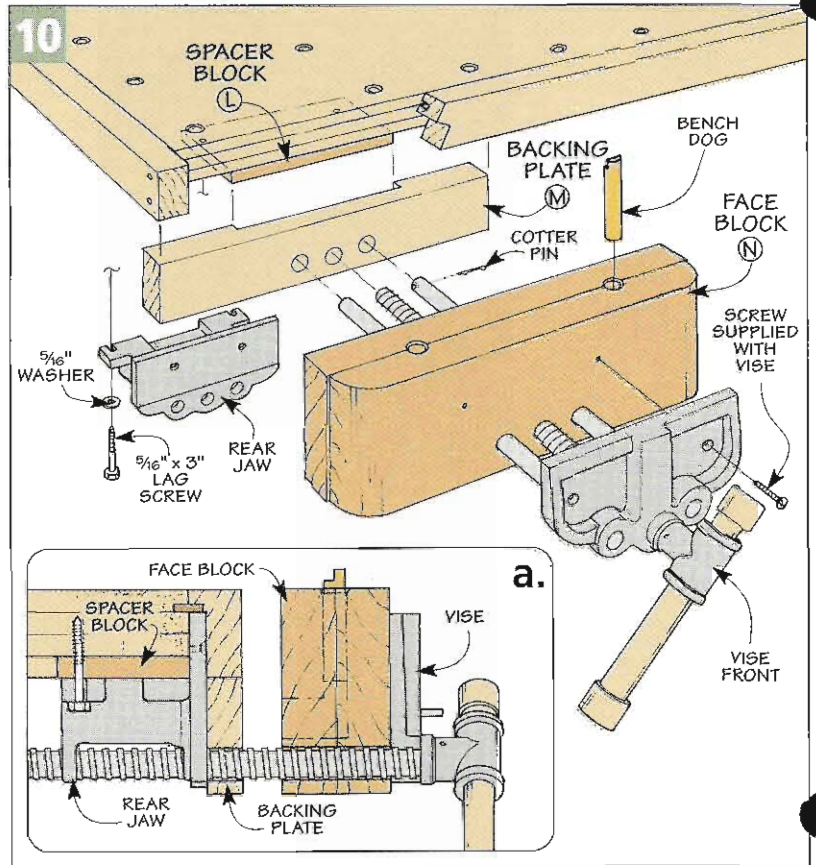

don't worry. This isn't as difficult as you might think. After removing a cotter pin from one of the guide rods, I was able to separate the front jaw (along with the guide rods and threaded shaft) from the rear jaw. (For more on the vise I used, refer to Sources on page 35.)

As I mentioned earlier, you've already completed the first step of

installing the vise by routing out the pocket in the front apron for the rear jaw. At this point, you're ready for the second step by adding a couple support pieces for the rear jaw.

**Spacer Block** - To fill the "gap" between the bottom of the benchtop and the vise mounting plate, I added a *spacer block* (L) made from 3/4" MDF. The block is simply glued and

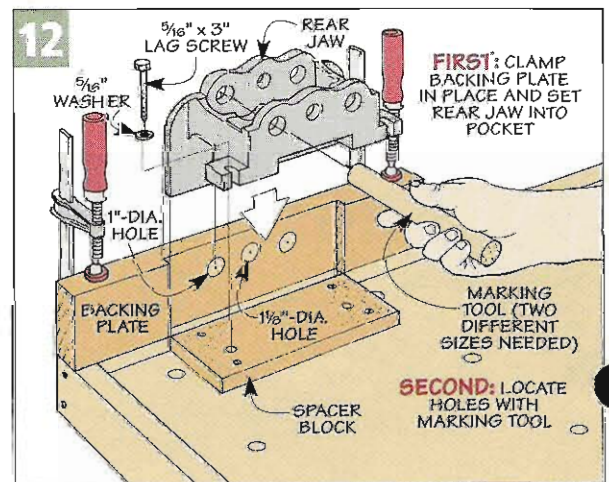
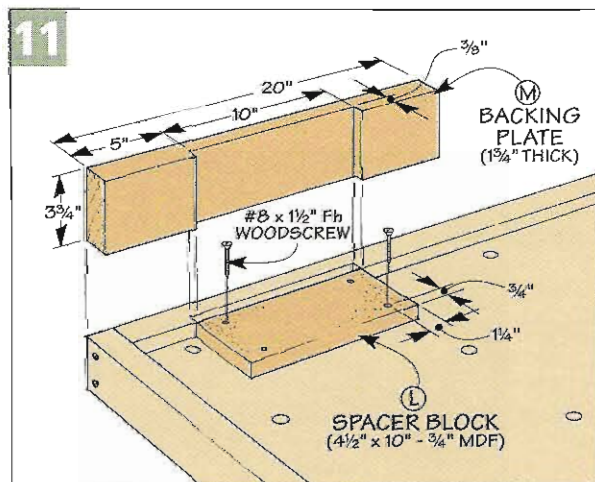

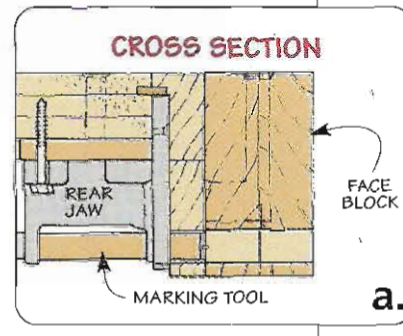
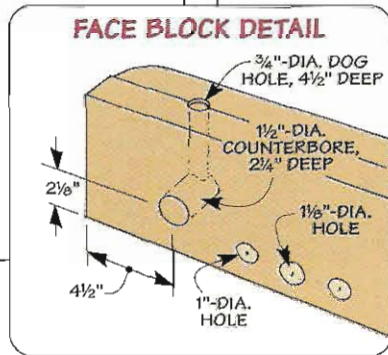
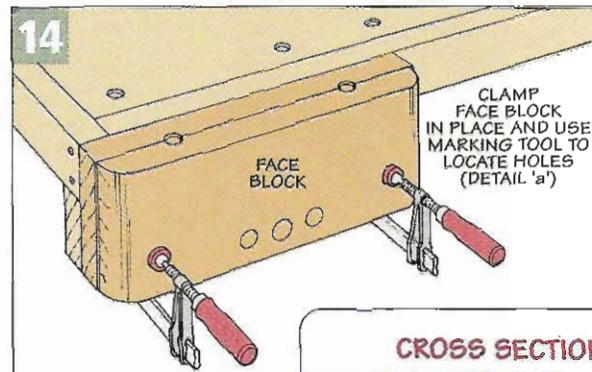
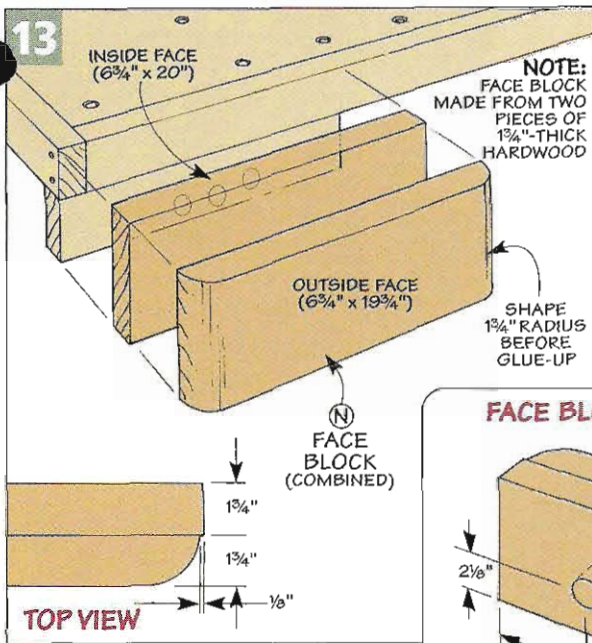

screwed in place so it's flush with the inside edge of the pocket, as illustrated in Figure 11.

**Backing Plate** – The second support piece is a *backing plate* (*M*) made from 1 3/4"-thick hardwood that matches the thickness of the front apron (Figure 11). Here again, to allow for the rear jaw of the vise, a wide dado is cut in the plate.

After cutting the dado, the next step is to temporarily clamp the backer plate to the bench so it's flush with the apron all around (Figure 12). Now you can slip the rear jaw of the vise in place as a "template" for locating the holes that the guide rods and threaded shaft pass through.

Since it was hard to make an accurate mark using a pencil, I made a couple of marking tools. Each has a nail ground to a point centered in the end of a dowel. (You may have to sand the dowel to fit smoothly into the holes in the vise.) Marking the center of each hole is just a matter of "poking" the nail against the plate.

Once you've marked the location of all three holes, remove the backing plate and drill the holes. But don't worry about being dead-on accurate. The holes are slightly oversized (1/8") to provide a little clearance.

After drilling the holes, you can glue the backing plate to the bottom

of the front apron. Just be sure to attach it flush on the face and end.

**Face Block** – While you wait for the glue to dry, you can work on making and mounting the *face block* (*N*), like the one shown in Figure 13. The block consists of two slabs of 1 3/4"-thick hardwood.

But before gluing them together, I softened the outside edge of one block by cutting a radius, as you can see in Figure 13. If your band saw has the capacity for 6 3/4"-wide stock, you can do this easily.

If not, it's a simple matter to lay out the radius on the ends of the workpiece and remove most of the waste by making a few passes across a table saw with the blade tilted. Then you can smooth out the radius with a rasp and sandpaper.

**Dog Holes** – After gluing the pieces together, you'll need to lay out and drill a couple dog holes in the bench. But you'll notice in the Face Block Detail above that I didn't drill completely through the block. That's because the bench dogs I used are shorter than the width of the face block. So I drilled a pair of counterbores on the *inside* face of the

block to provide easy access, as you can see in the margin photo.

**Vise Holes** – At this point, you're almost ready to mount the vise. But before you do that, you'll need to drill a set of holes for the guide rods and threaded shaft. Here again, these holes need to match the ones already drilled in the backing plate.

In Figure 14 you can see the procedure I used to transfer the hole location. The important thing here is to make sure the face block is flush with the top and end of the bench.

Then using the same dowels as before, mark the location of each hole (Figure 14a). Once that's complete, remove the block and drill the holes. As before, they're slightly oversized so the precise locations aren't critical.

**Mount Block & Vise** – After mounting the rear jaw, you're ready to attach the face block to the front jaw. To do this, I used the vise to "clamp" the block against the apron with the top edges and ends flush. As shown in Figure 10, two screws secure the block to the front jaw.

Don't worry if you notice a small gap between the apron and bottom of the face block. The jaws cant (tilt) in slightly at the top. The reason is that as you clamp a workpiece, it forces the top of the vise apart, and the tilt keeps the jaws parallel.

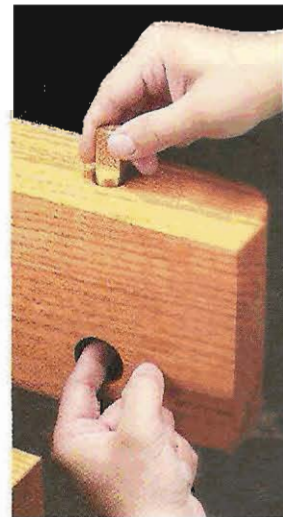

▲ **Finger Holes.** Access holes drilled on the inside face of the vise make it easy to "pop up" a bench dog for easy removal.

# Twin-Screw End Vise



One of the more interesting features of this workbench — and a feature I've wanted to incorporate for awhile — is the *Veritas* Twin-Screw Vise shown above. This vise has a chain-driven mechanism (see inset) that keeps the jaws of the vise perfectly parallel during any type of clamping. (For more information on this vise, refer to Sources on page 35.)



▲ With the vise cover removed, you can see the chain-drive mechanism that operates the vise.

**End Apron** — If you've decided to install the twin-screw vise, the first step is adding an end apron to complete the top of the workbench. Like the other aprons, this one is  $1\frac{3}{4}$ " thick. But the *end apron* (O) is wider to accommodate the twin-screw vise hardware (Figure 15).

As you did before, you'll need to rout a slot near the top to accept the

spline used to align the apron with the top of the bench. (Remember to stop the slot short of each end of the apron.)

**Vise Holes** — Once the slot is cut, you're ready to add the holes for the shafts of the vise. Because there's no metal jaw and the two shafts are independent, you can simply lay out the holes and drill them to fit the mounting flanges supplied with the twin-screw vise.

The twin-screw vise doesn't have any guide rods either. So to avoid having to rest your workpiece on the shafts, there are a pair of steel support pins installed in the apron. You can see where to locate these holes by taking a look at Figure 15. But don't install the pins just yet.

**Apron Braces** — To provide extra support for the end apron where it extends below the front/back aprons, I added a pair of *braces* (P). They're made from  $1\frac{3}{4}$ "-thick hardwood. And as you can see in Figure 15, I shaped them like the stretchers on the base. The braces are then simply glued and screwed in place.

**Face Block** — Like the face vise, the twin-screw vise has a face block also (Figure 16). The *twin-screw face*

*block* (Q) is built identically. It's simply longer (27") so it's flush with both the front and back of the benchtop.

Here again, you'll need to lay out and drill a pair of dog holes in the top of the block, as well as a pair of counterbores on the inside face for "popping" the dogs out of the holes.

**Vise Installation** — At this point, you're ready to mount the face block and twin-screw vise hardware. The first step is just like before — locating the shaft holes. So start by clamping the face block to the end apron so it's flush all around.

This time I had a little more room to transfer the location of the holes, so I just slipped a pencil inside and traced the location of the shaft holes to the face block.

Once that's complete, you can remove the face block and drill the holes. Just remember that these holes don't need to be as large. I measured the shafts (about 1") and drilled them slightly ( $\frac{1}{8}$ ") oversized.

Remember the pins that support the workpiece? Well, the face block needs to have a couple counterbores drilled in it so the pins have a "home" when the vise is completely closed. The process for locating these holes is just like before, but be sure to use the *layout* hole to locate them, not the smaller hole you just drilled.

Now you can tap the pins (supplied with the vise) in place and then reclamp the face block to the apron in preparation for installing the rest of the twin-screw vise hardware.

**Install Shafts** — The shafts of the vise are held in place by a pair of flanges mounted to the back side of the apron (Figure 17). Before you screw them in place, take a look at where the thread starts on each one and orient them identically (Figure 17a). (I used a piece of tape for reference.) This ensures that the two handles will be positioned identically (or pretty close).

The next step is to thread each shaft into the flange and snug the face block up against the end apron so it's

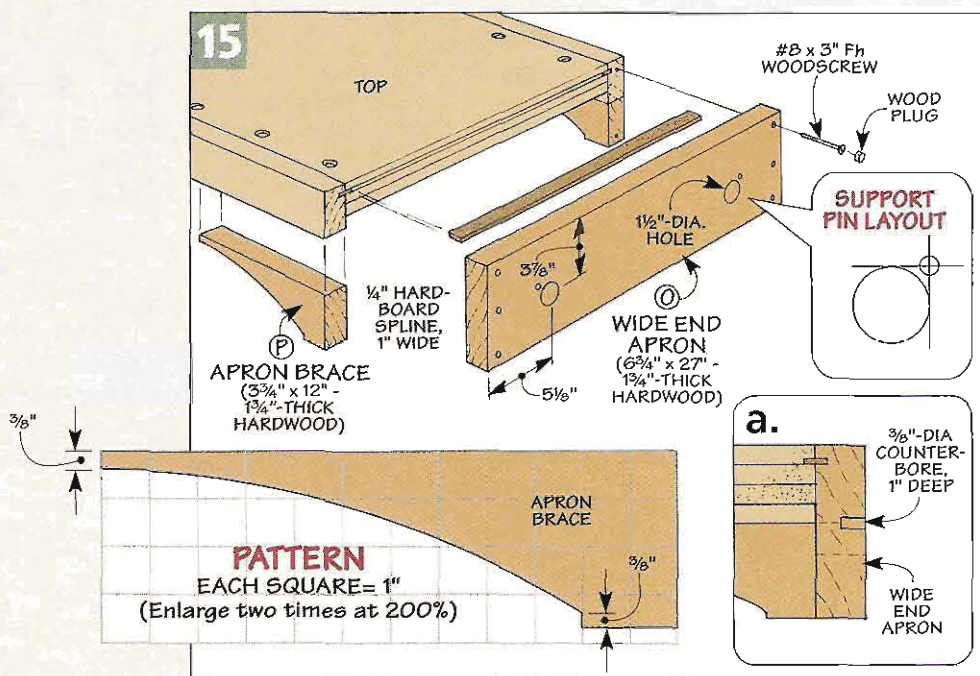

flush all around. (Note: The shaft with the spring-loaded sprocket pin that allows the vise to be canted is installed on the right side, as shown in Figures 18a and 19.)

You'll also want to "tweak" the shaft mounting plates so they're positioned vertically (Figure 17). Then you can screw the plates to the front of the face block.

**Rub Plates** – One thing I noticed about the vise was that it dropped slightly the further out it was extended due to play in the threads of the vise. To minimize this, I took some time to install a couple *rub plates* (R) underneath the top (Figures 18 and 18a). I sized mine to provide  $1/16"$  clearance above the shaft and then screwed them in place.

**Final Assembly** – Completing the installation of the vises is just a matter of adding the drive chain, covers, and handles (Figure 19).

To install the chain, place it over the right sprocket and then pull it over the left sprocket. What you're looking for here is to have the chain engage the left sprocket so it's fairly taut across the top.

A pair of set screws in the left sprocket allows you to adjust the chain so it's taut. Then it's just a matter of joining the chain with the connecting link provided in the kit.

One thing you may notice is the lower chain sags more than half a link. If that's the case you may need to

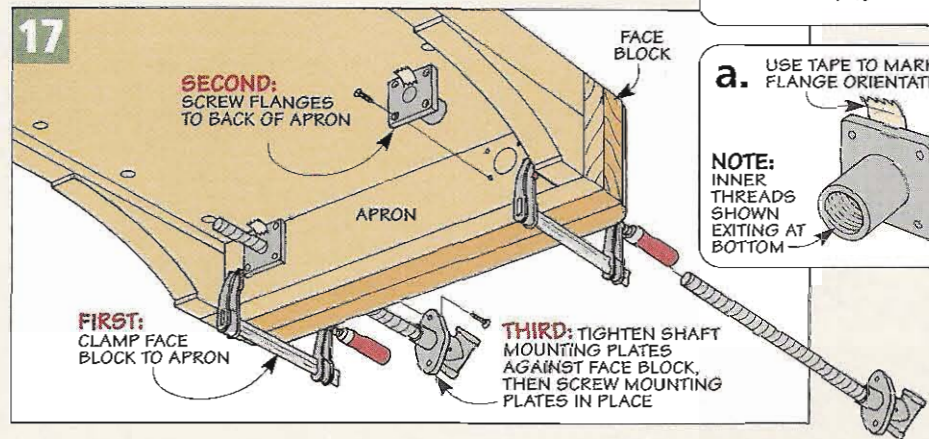
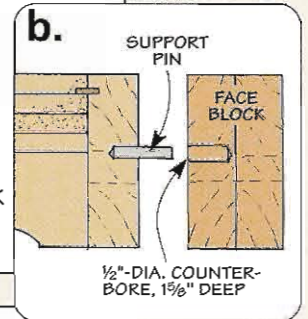
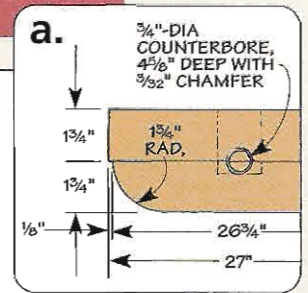
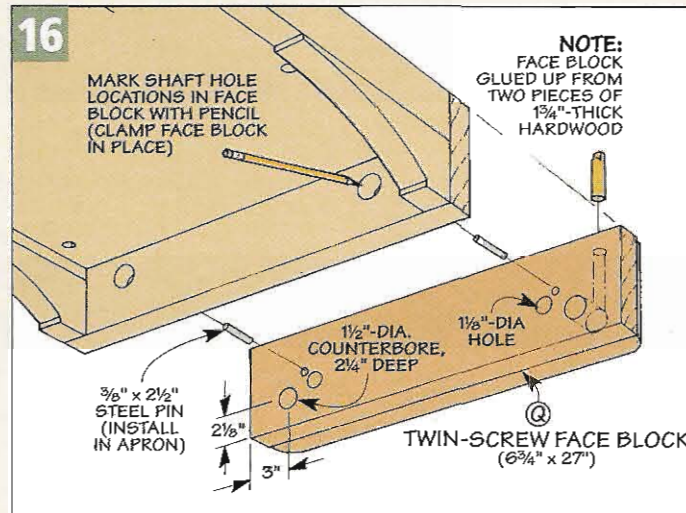

remove a full link and reinstall a half link. This hardware and the instructions for accomplishing this are included with the twin-screw vise kit.

With my vise, after rejoining the chain with a half link, there was still a little minor sag. To "prop" this up a

bit, I installed the chain roller supplied with the twin-screw hardware (Figure 19). Finally, screw the covers in place and add the handles. (Note: Additional hardware is included for installing a "speed" knob. For more on this, refer to page 29.)

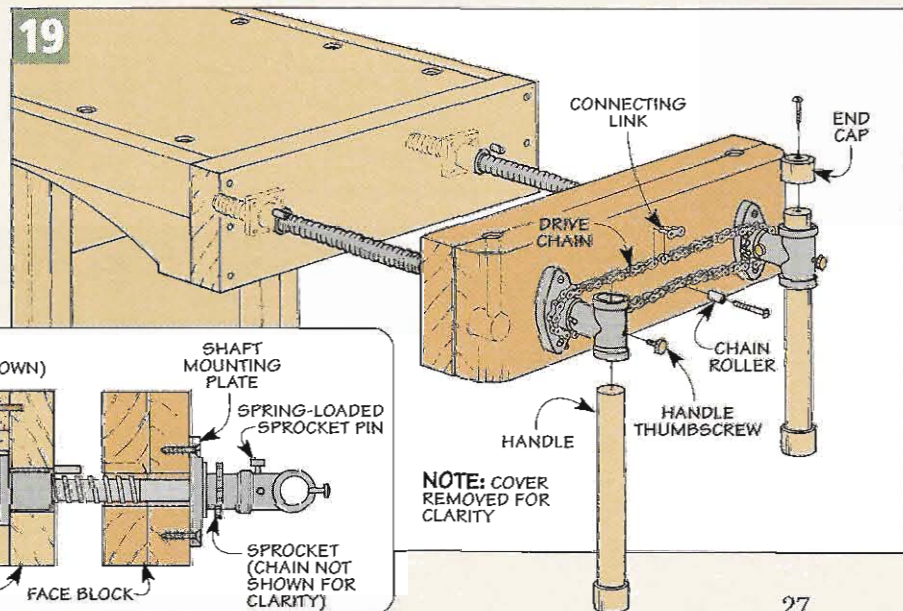
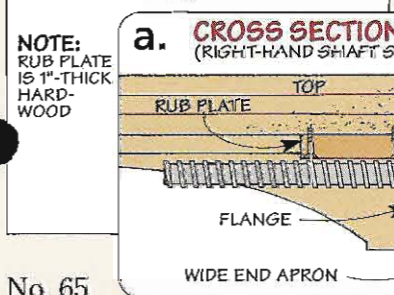
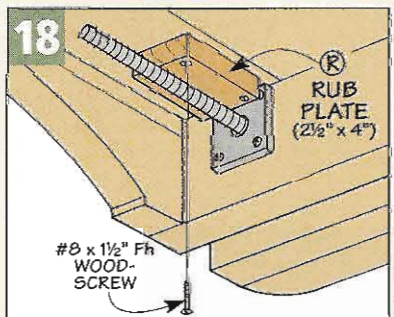

# Final Details

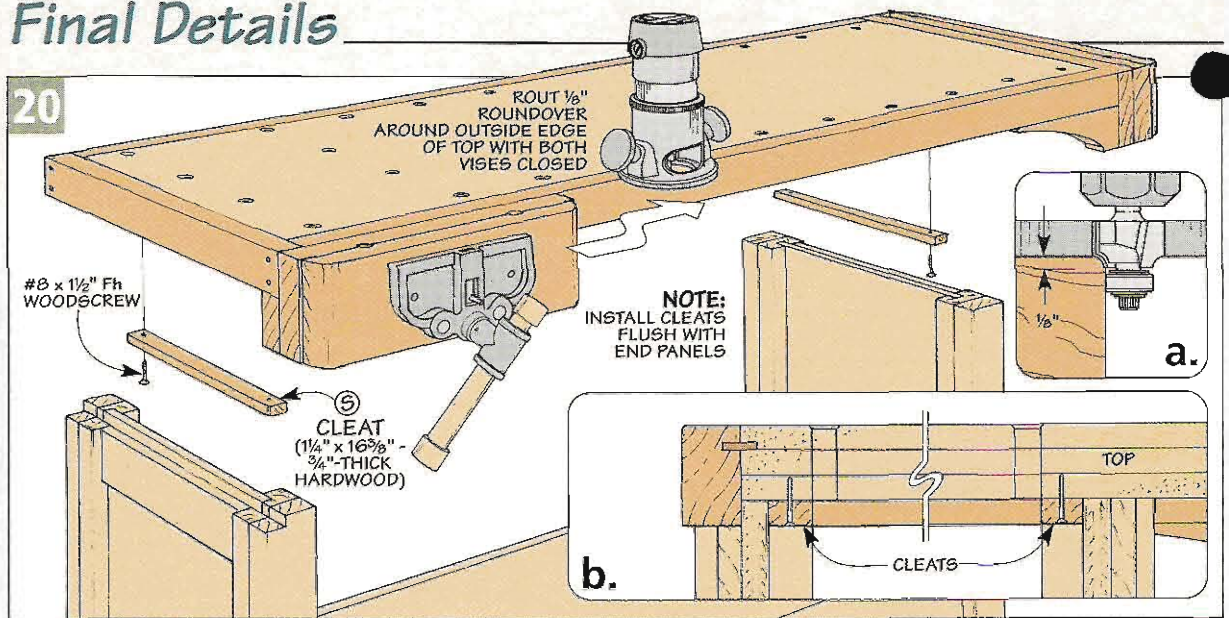

Completing the installation of both vises was probably the biggest challenge in building the workbench. All that's left to do now is put the top in place, complete a couple small details, and then apply a finish.

**Install Top** – Installing the top doesn't involve a whole lot more than simply setting it in place on the base. But as you've figured out by now, it's a little too heavy to do that all by yourself. So you'll want to call a friend to give you a hand in placing the top in position.

As you can see in Figure 20 above, the top rests on the upper face of the legs. It's positioned so the apron at

the left end "hooks" around the rabbet at the top of the left end assembly (Figure 20b).

**Cleats** – Although the weight of the top will keep it from lifting off, I wanted to make sure the top wouldn't shift or slide around at all as I worked. So I added a pair of cleats to the underside (Figure 20).

These *cleats* (S) are 3/4"-thick hardwood strips. They're cut to fit between the front and back legs. The cleats are installed flush against the panel of each end assembly, as you can see in Figure 20b.

**Soften Edges** – Once the cleats are in place, there's one last detail to

take care of. And that's to soften the outside edges around the top. I waited until the vises were complete before doing this because I wanted to incorporate the roundover into the face blocks of each vise.

To do this, I snugged up each vise so it was tight against the bench top. Then I slipped a small (1/8") round-over bit in my hand-held router and routed around the top and the face blocks. You can see this detail in Figure 20a.

The bearing on the round-over bit doesn't allow you to rout the roundover all the way into the corners of the face blocks. So after

## Materials

### Base

A Legs (4)	3 1/2 x 32 3/4 - 3 1/2
B End Panels (2)	18 3/8 x 28 1/4 - 3/4 Ply.
C Filler Strips (4)	1 x 4 1/2 - 3/4
D Narrow Upr. Rail (1)	4 1/2 x 16 3/8 - 3/4
E Wide Upr. Rail (1)	5 1/4 x 16 3/8 - 3/4
F Lower Rails (2)	7 x 16 3/8 - 3/4
G Stretchers (2)	7 x 57 1/4 - 1 3/4
H Shelf (1)	19 3/8 x 60 1/2 - 3/4 MDF

### Top

I Top Layers (3)	23 1/2 x 75 - 3/4 MDF
J Front/Back Aprons (2)	3 x 75 - 1 3/4
K End Apron (1)	3 x 27 - 1 3/4

### Front Vise

L Spacer Block (1)	4 1/2 x 10 - 3/4 MDF
M Backing Plate (1)	3 3/4 x 20 - 1 3/4
N Face Block (1)	6 3/4 x 20 - 3/2

### Twin-Screw End Vise

O Wide End Apron (1)	6 3/4 x 27 - 1 3/4
P Apron Braces (2)	3 3/4 x 12 - 1 3/4
Q Twin-Screw Face Blk. (1)	6 3/4 x 27 - 3 1/2
R Rub Plates (2)	2 1/2 x 4 - 1
S Cleats (2)	1 1/4 x 16 3/8 - 3/4

Note: For this project, you'll need a total of 2 sheets of 3/4" MDF, 1/2 sheet of 3/4" plywood, 56 bd. ft. of 8/4 hardwood, and 4 bd. ft. of 4/4 hardwood.

## Hardware

- (30) #8 x 1 1/4" Fh Woodscrews
- (16) #8 x 1 1/2" Fh Woodscrews
- (10) #8 x 3" Fh Woodscrews
- (8) 1/2" x 1 1/2" Steel Rods
- (2) 5/16" x 3" Lag Screws
- (2) 5/16" Flat Washers
- (4) Bench Bolts and Barrel Nuts
- (4) 1/2" Flat Washers
- (1) Woodworking Vise
- (1) Twin-Screw End Vise
- (1) Set of Bench Dogs
- (1) 1/4" Hdbd. (1" x 200 Ln. In.)
- (10) 3/8"-Dia. Hardwood Plugs

Sources for the front vise, twin-screw end vise, bench bolts and nuts, and bench dog accessories are detailed on page 35.



▲ **Mixing the Finish.** Mixing three tablespoons of Van Dyke brown artist's oil color with a quart of finish gives the workbench a nice, antique oak look.

you're done routing, you'll need to clean up these inside corners with some sandpaper.

**Dog Holes** – As I was test fitting some bench dogs in the holes in the top, I noticed a couple fit a little too snug, making it difficult to remove the bench dog.

Solving this problem was just a matter of wrapping a strip of sandpaper around a dowel and sanding the inside of any hole that was a little too tight.

At this point, all that's left to do is protect the workbench by adding a finish. But before you do that you might want to take a look at a couple options for the workbench shown in the box below — leather vise faces and a speed knob for the twin-screw vise.

### FINISH

For the finish on this workbench, you could simply use a wipe-on varnish. But I wanted to give the red oak an old-time, antique look.

To do this, I experimented with some artist's oil colors I picked up at a local art supply store. They come

in toothpaste-style tubes, like the one you see in the margin.

I experimented with a few different colors, combining them in small batches until I found a color I liked. Just keep in mind that too much color will make things look muddy. Too little and everything looks washed out.

My final "mix" ended up being quite simple — a few tablespoons of Van Dyke Brown in a quart of linseed oil (see photo at left). (You could also mix the artist's colors in a wipe-on varnish if you'd like a little more gloss and durability.)

With the mix in hand, just wipe the finish on and work it around evenly to avoid streaking. And yes, I even used the finish on the MDF.

It made the whole workbench look like it just came out of an old-fashioned workshop.



▲ **Artist's Oil Colors.** Mixing up a custom stain is easy with artist's oil colors. Simply squeeze out a few dabs and mix it with an oil finish of your choice.

## Workbench Options

The front vise on this bench has a built-in quick-release feature. But the twin-screw vise doesn't. So opening (or closing) the vise quickly can be a hassle.

**Speed Knob** – Fortunately, the twin-screw vise I used came with some additional hardware that makes the job a whole lot easier — a speed knob (see photo and inset below).

Installing the knob is just a matter of drilling a hole through the end of one of the handles and installing the hardware. Considering how quickly you can open and close the vise, it's an option I can't

imagine doing without. (I put mine on the handle towards the front of the bench)

**Leather Faces** – Another option I'd recommend adding is the leather faces shown in the photo at right. Although both vises will hold a workpiece securely, leather provides a solid grip (without having to really crank down on the vise handle) that's also easy on the workpiece.

Adding a leather face to a new (or existing vise) isn't as hard as you might think. As a

matter of fact, the toughest job might be finding the leather. (I went to a local leather retailer I found in the yellow pages.)

The first thing you'll need to do is make cutouts in each face for any finger holes, guide rods, or threaded shafts, like the ones you see in the photo above.

I laid out the locations of the holes on an oversized (1/4") piece of leather. Then, after



carefully cutting out each opening, I made a vertical cut to the bottom of the leather. This allowed the facing to slip over the rods and shafts. (You could also disassemble the vise and install the leather without making any vertical cutouts.)

All it takes to attach the leather at this point is a little contact cement. After applying the cement to both the vise face and leather, I used a roller to bond the leather to the wood. Once that's complete, you can trim the leather flush with the edges of the bench and face blocks.



# Edge-Sanding Block

*Precision sanding is a snap with this adjustable edge-sanding block.*



Used alone or as a “base” for plastic laminate, plywood is a versatile material. But even with the best-looking plywood, you’ll still want to cover the edges. I usually do this with some hardwood edging, like you see in the photo above.

The problem is sanding the edging perfectly flush without going a little too far and sanding scratches in the face veneer or laminate.

**Edge-Sanding Block** – But with the edge-sanding block shown in Figure 1, that’s not a problem any more. This block makes it easy to sand a piece of edging precisely — whether it’s 1/4" wide or 2 1/4" wide.

**Adjustable** – This sanding block is precise because it’s adjustable. To do this, a cork-backed sanding pad can be positioned to match the width of the edging and then locked in place by a fence (Figure 1b).

**Body** – I started on the sanding block by making the body. The body (A) starts out as a 2 1/4"-thick hardwood blank. I found it easiest to glue up an oversized blank from three layers of 3/4"-thick material.

Once the glue dries, cut the blank to final size and then lay out the shape of the body on the side, as illustrated in Figures 2 and 2a. But before you cut the body to shape, there are a couple things to do.

The first thing is to provide a way to hold the pad in position and provide a “stop” as you sand. This is accomplished by a fence that will be added later (Figure 1b).

**Inserts** – But to lock the fence in place, you’ll need to install a set of threaded inserts. To do this, I drilled a hole in each corner of the bottom of the blank (Figures 2 and 2a). This way, you can install the fence either left- or right-handed work.

Once the holes are drilled, it’s a good idea to install the threaded

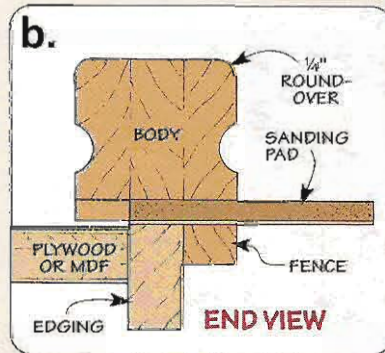
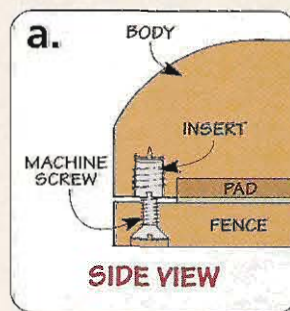
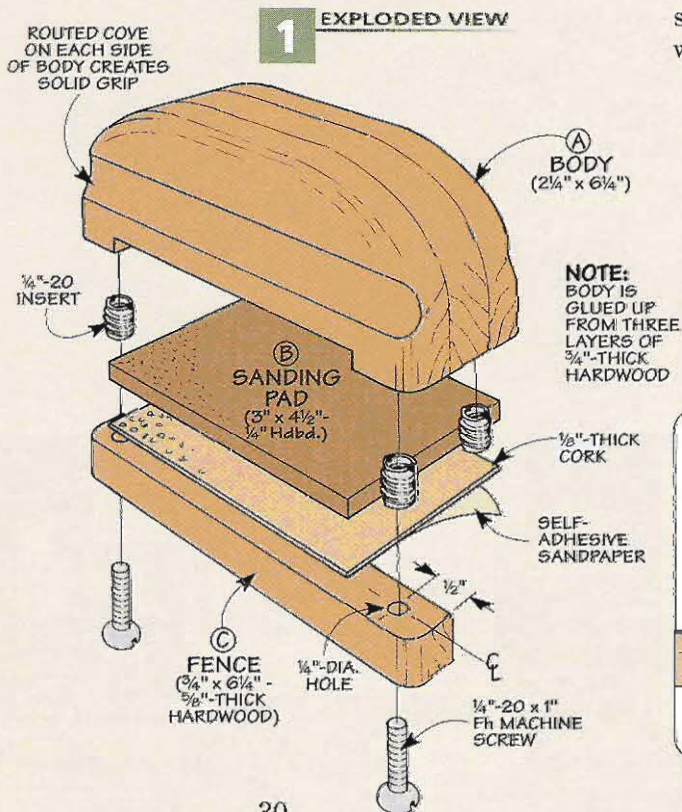

inserts. But why install them now?

The reason is that if you wait until *after* you cut the dado for the sanding pad, it's all too easy to "blow out" the thin wall of the hole next to the dado. Note: For a sure-fire way to install the inserts perfectly the first time, check out the margin at right.

**Cut Dado** – The other thing to do before shaping the body is to cut a shallow ( $\frac{1}{4}$ " ) dado that's centered on the bottom of the body to fit the sanding pad. This sanding pad is sized to hold a piece of  $4\frac{1}{2}$ "-wide self-adhesive sandpaper that comes in long rolls.

As you can see in Figures 3 and 3a, I used a dado blade in the table saw to cut the dado. And I attached an auxiliary fence to the miter gauge to provide support for the body and prevent chipout on the back side.

**Shape Body** – At this point, you're ready to shape the body. Start by rough cutting just outside the layout lines on the band saw. Then you can use a rasp and some sandpaper to smooth things out. As you do this, it's a good idea to "test drive" the block until it feels comfortable.

Then to provide a solid grip, I added a shallow cove to each side of the body. A core box bit makes quick work of this (Figures 4 and 4a). Finally, soften the top edges of the

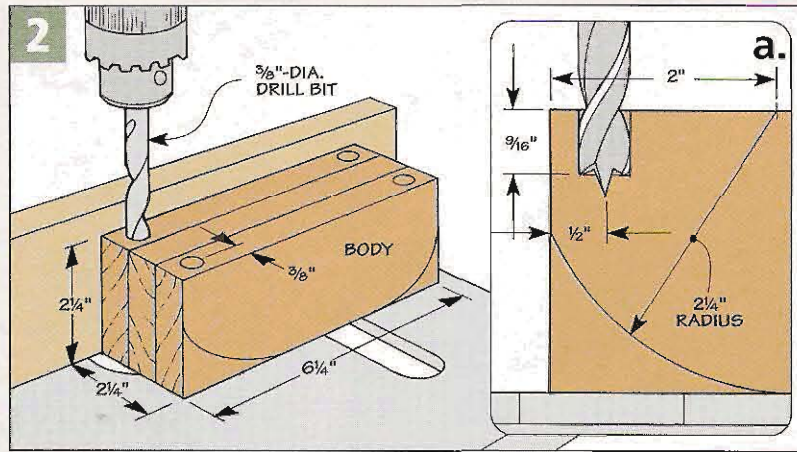

block with a  $\frac{1}{4}$ " round-over bit (Figures 1 and 1b).

**Sanding Pad** – You can set the block aside now and concentrate on the sanding pad. The *pad* (B) is nothing more than a piece of  $\frac{1}{4}$ " hardboard that's cut to fit the dado in the bottom of the body.

To provide a little "cushion" as you sand, there's a layer of cork attached to the bottom of the pad. I glued an oversized piece of cork to the pad and then trimmed it to match.

**Fence** – Now all that's left to do is make the fence. The *fence* (C) is a piece of  $\frac{5}{8}$ "-thick hardwood with the outside corners rounded slightly.

As you can see in Figure 1, I drilled a countersunk hole near each end of the fence to match the holes in the bottom of the body.

**Setup & Use** – Using the sanding block couldn't be simpler. Start by unrolling a piece of self-adhesive sandpaper and stick it to the sanding pad. Then trim it to match, like you see in the photo below.

All that's left to do now is slide the pad between the body and fence until the exposed sandpaper matches the width of the edging (lower photo). After tightening the screws to "pinch" the pad in place, the sanding block is ready to go.

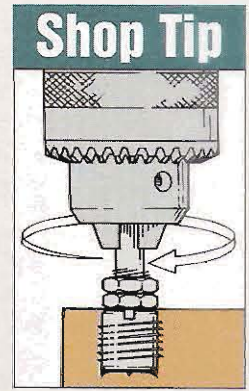

**Shop Tip**  
Installing a cut-off bolt and a couple nuts in the drill press makes it easy to install inserts perfectly straight. Safety Note: Rotate the chuck by hand.

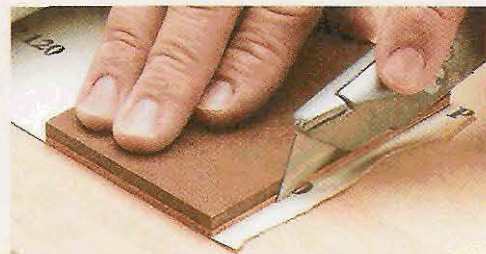

▲ **Size the Sandpaper.** After sticking an oversized piece of sandpaper to the pad, use a utility knife to trim the edges flush.

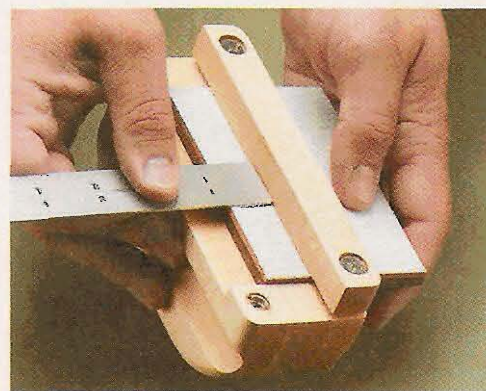

▲ **Setup.** Now adjust the sanding pad to match the width of the edging. Then tighten the screws to lock the fence in place.

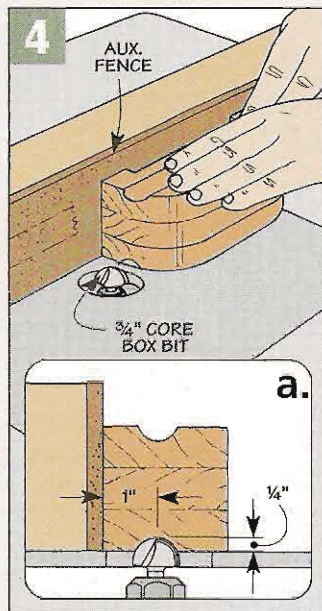
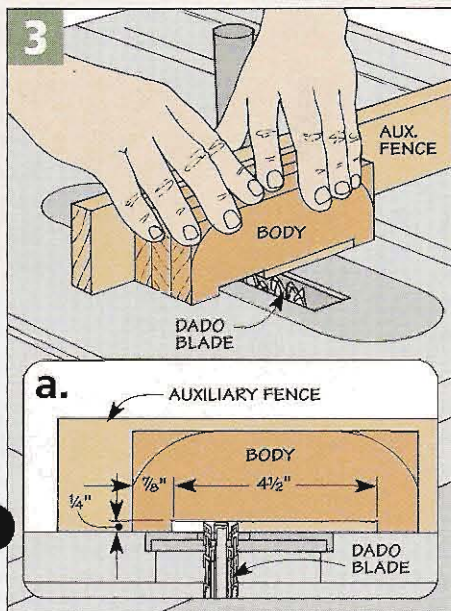

# Shop Talk

*Far from being obsolete, hand planes deserve a place in every woodworking shop.*



**Block Plane**

**#7 Jointer Plane**

**#5 Jack Plane**

**T**here's nothing quite like using a sharp, well-tuned hand plane. All you hear is the "schwoop" of the plane as it slides over the wood, peeling off thin, wispy shavings and leaving behind a glass-smooth surface that you just can't get by sanding. Hand planing is truly one of the most enjoyable experiences in woodworking.

If you think hand planes are old-fashioned and outdated, you might want to re-consider. Power tools may have replaced hand planes for a lot of the grunt work of thickening and dimensioning stock, but there are still places where a hand plane is quicker and easier to use. That's why in my shop I use hand planes right alongside with my power tools.

But where do you start? In the past, there were dozens of different types of hand planes, each designed for a special purpose. Today, the choice is a bit more limited, but it's still easy to be confused by the assortment available. Why are there so many sizes, and more importantly, which ones do you need?

**Block Planes** – If you're only going to own one hand plane, a block plane is the one to get. In fact, I would go so far as to say this is one plane that *every* woodworker should own. My block plane gets used on just about every project I build. It's called into service for all kinds of routine tasks such as chamfering, trimming edging, or flushing up a rail and stile joint, see photo below. It fits comfortably in one hand, and it slips nicely into the pocket of my shop apron when I'm done.

Block planes are available in two versions — a standard-angle and a low-angle. The difference is in the angle at which the blade is set or "bedded." On the standard-angle plane, the blade is usually bedded at a 20° angle. On the low-angle plane, the bed is at a 12° angle.

I use both types of block planes in my shop, and they each have their place. The low-angle plane excels at cutting end grain, see margin photo at left. The low angle of the blade allows it to slice through the wood easier. But it doesn't do so well when

cutting long grain. (It tends to lift and tear the grain.) So if I could have only one of these planes, it would be the standard-angle block plane. It's the one I use most, and it's better suited for general, all-around work. But truth is that I wouldn't want to be without either one.

**Bench Planes** – After block planes, bench planes are probably the most commonly used hand planes. Bench planes are numbered from #1 to #8 according to their size. In addition to the numbers, bench planes are also named for the job they do. The smaller sizes are known as



▲ **Low-Angle Block Plane.** A low-angle block plane is a good choice for cutting end grain, like the pins on this dovetail joint.



▲ **Block Plane.** A block plane can quickly trim a rail so it's flush with a stile, either before or after the pieces are assembled.

“smoothers” or smoothing planes and are used for final surface preparation. The longest planes are called jointers. They’re used for flattening and leveling stock, as well as creating straight edges when gluing boards into a panel. In between the smoother and the jointer is the jack plane.

The jack plane (#5) is probably the most common of all the bench planes, and it’s a good one to purchase if you plan on buying only one bench plane. This plane will do just about anything you need it to, from smoothing to jointing to thickening, see photo at right. It really is a “jack-of-all-trades,” which might explain how it got its name. But while a jack plane can be used in a lot of situations, it’s often a compromise.

If you decide that you really like using hand planes, I would suggest adding a smoother (#4) and a jointer (#7). The reasons for this are simple. If you are trying to create a straight edge or level out the face of a board, a smoother plane tends to run up and down over the “hills and valleys” of the wood. But a longer jointer plane will ride over only the high spots, removing them quickly and leveling out the workpiece, see photo below.

By the same token, the shorter length of a smoothing plane allows you to concentrate your planing on a specific area, like a patch of difficult grain. And because



▲ **Jack Plane.** A jack plane like this #5 can be used to quickly flatten a glued-up panel. Once the panel is level, you can use a smoothing plane (#3 or #4) to remove any planing marks left behind by the jack plane.

smoothing planes are smaller and lighter, they aren’t as tiring to use as a jointer or a jack plane.

**Corrugated Sole** – One common feature you may run across on bench planes is a “corrugated” sole (see margin photo at right). This is just a series of shallow grooves milled into the sole (bottom) of the plane. The grooves supposedly help reduce friction between the plane and the wood, making planing easier. I have both kinds of planes (corrugated and smooth sole) in my shop, and I can’t really tell any difference. But it’s worth knowing what the grooves are for.

**Where to Buy Planes** – You might be able to find a block plane or jack plane at your local hardware

store or home center. But frankly, I would steer clear of these planes. You are generally better off buying planes from a place that specializes in woodworking tools. (Most of the woodworking mail order companies carry hand planes.) *Stanley* and *Record* are two of the better known brands of plane-makers, and their planes are reasonably priced. (You can expect to pay \$40-\$50 for a block plane and slightly more for a bench plane, depending on the size.)

Another option to consider is a used plane. You can often buy a used plane for a fraction of the cost of a new one. And many woodworkers actually prefer older planes over newer ones. But if you decide to go this route, it pays to thoroughly familiarize yourself with hand planes before buying one so you can tell if any parts are missing or damaged.

Whether you buy new or used, you’ll need to spend some time tuning up your plane and sharpening the blade. (There are several good books and articles that can help you do this.) But the most important thing is to make sure you use it. Get some scrap wood and start making shavings. It takes a little practice at first, but once you get the hang of using hand planes, I bet you’ll be hooked. 🛠️



▲ **Corrugated Sole.** Shallow grooves milled into the sole of this plane are designed to decrease friction while planing.



▲ **Jointer Plane.** The long sole of this #7 jointer plane helps to level the high spots and create a smooth, straight edge on the workpiece. This is important for getting strong, tight-fitting joints when edge-gluing boards.

# Tool Chest

**S**afety glasses and dust masks may not revolutionize your woodworking, but they can make your time in the shop a lot more comfortable. And in the case of the *Woodshop Specs* safety glasses and the *Dust Bee Gone* dust mask shown at right, this couldn't be more true.

## WOODSHOP SPECS

One of the biggest problems with safety glasses is trying to do work “up close and personal” — like layout work, or marking and measuring. And if you need reading glasses (like I do), you're out of luck or have to switch back and forth — a pain, and sometimes a safety hazard, when you're working with power tools.

So you can bet I paid close attention when I ran across *Woodshop Specs* by Wizard. They're safety glasses with bifocals *built in*. This makes it easy to do detailed work without having to remove my safety glasses, as demonstrated in the photo below.

**Cost & Availability** — Like other safety glasses, *Woodshop Specs* come as “one size fits all.” But the nice thing

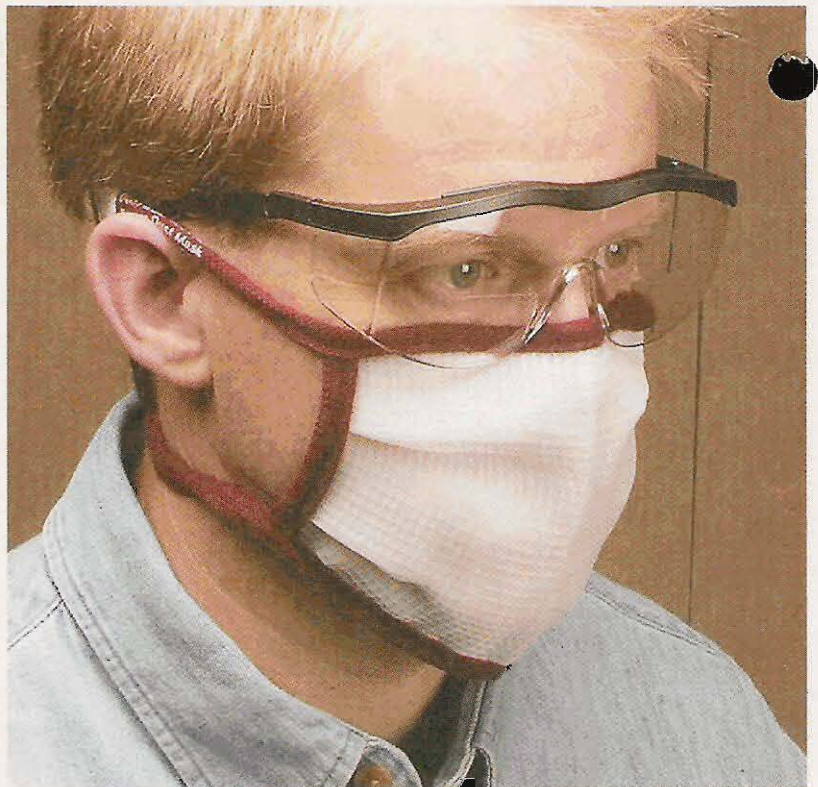

## Woodshop Specs & Dust Bee Gone

is you can adjust both the *length* and *angle* of the temples for a perfect fit. The only thing you'll need to specify is what strength you need (+1.0 to +3.0 diopter in 0.5 increments).

The *Specs* are reasonably priced at \$19.95. So there's no reason not to buy a pair. To locate a source near you, see the box in the margin.

## DUST BEE GONE

Another product that caught my “eye” is a dust mask called *Dust Bee Gone*. There are a couple big reasons that I really like this mask.

First, unlike a paper mask, the *Dust Bee Gone* is made from a woven polyester and has adjustable cloth straps. So it's extremely comfortable. As a matter of fact, I'm more likely to wear it into the house than to “forget” to wear it in the shop.

Another benefit is that my safety glasses don't fog up any more. With my old mask, my glasses fogged up so

much it became a hassle to wear the dust mask. But the *Dust Bee Gone* is guaranteed not to fog your glasses.

The *Dust Bee Gone* is classified as a *nuisance* dust mask. So it won't filter out the really fine dust particles. (According to the manufacturer, it will filter particles down to three microns). But combined with an overall dust collection system, it's a great improvement.

**Cost & Availability** — The *Dust Bee Gone* mask is available in four sizes — youth, medium, large, and extra-large (they're based on neck size). So you're sure to find one that fits just right. If there's a “downside” at all to the *Dust Bee Gone*, it's the fact that each mask costs about \$35.

Expensive? Not really, considering this mask should last many years (it can be hand washed). You'd be certain to spend more over that same time frame on disposable paper masks. For sources, see margin. 

## Sources

### Woodshop Specs:

- Wizard:  
woodshopspecs.com  
888-346-3826

### Dust Bee Gone:

- Fajo, Inc.:  
www.dustbeegone.com  
888-563-6355
- Woodcraft, Inc.:  
www.woodcraft.com  
800-225-1153

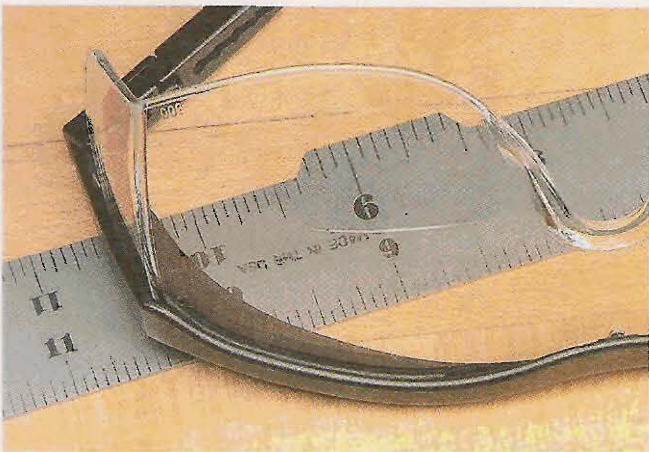

▲ **Built-in Bifocals.** *Woodshop Specs* are full-featured safety glasses with integrated side shields. And the built-in dual curvature mono-lens (bifocals) provide perfect close-up vision without the need for separate reading glasses.

# Sources

## Workbench Front Vise

A heavy-duty workbench like the one on page 18 deserves a matching vise. That's why I used a *Jorgensen* vise (4" x 10"), Model 41012.

**Quick Release** – As you would expect, the vise is solidly constructed. But what I really like is the quick-release feature that activates with

just a half-turn of the handle. This makes it easy to open (or close) the vise in an instant.

**Cost** – This vise, or similar models, will range in cost from \$135 to \$150. They're available from a number of woodworking stores or the sources listed at right.

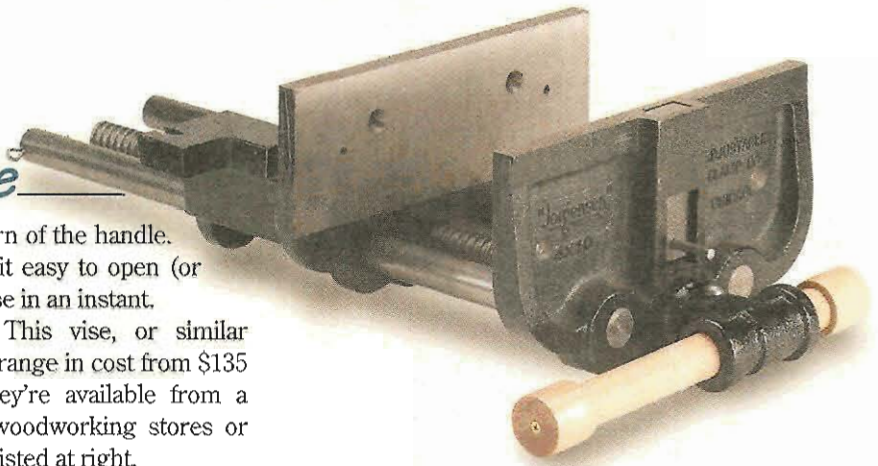

## Twin-Screw End Vise

The other vise I used on the workbench (page 18) is a *Veritas* twin-screw vise from *Lee Valley*.

**Vise Kit** – This vise is provided in the form of a kit (shown below). You can incorporate it into the design of a

new bench or retrofit it to an existing bench. The only thing you need to provide is a set of wood jaws sized for your bench. (The kit comes with a detailed set of instructions for installing all the hardware, as

well as suggestions on use and troubleshooting any problems.)

**Operation** – The vise gives you the ability to clamp a workpiece horizontally or vertically between the screws. And to keep the jaws perfectly parallel and prevent racking, the screws are driven by a chain. (A spring-loaded lock pin allows you to disengage the chain to slightly skew the jaws if necessary.)

**Cost & Availability** – The kit comes in two "sizes" depending on how far apart you'd like to space the screws. The 16<sup>7</sup>/<sub>8</sub>" kit I used cost \$149. A kit for spacing the screws between 16<sup>7</sup>/<sub>8</sub>" and 24" cost \$152. Sources are detailed in the margin.



## Workbench Accessories

A workbench isn't of much use if you can't secure your workpieces to it easily. A couple handy accessories for doing just that are shown below.

**Bench Dog** – The brass bench dogs (bottom of photo) fit in the holes in the face blocks and benchtop, making it easy to hold just about anything.

**Wonder Pup** – And what you can't secure with bench dogs and a vise can be handled with a *Wonder Pup* (shown at the top of the photo). A *Wonder Pup* works like a small vise and fits into a dog hole just like a bench dog.

The bench dogs and *Wonder Pups* are available from a number of sources (see margin).

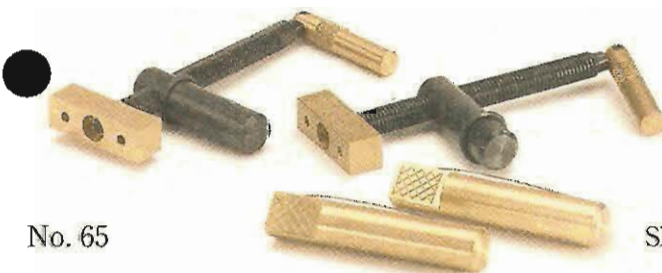

### MAIL ORDER SOURCES

**Lee Valley**  
800-871-8158  
www.leevalley.com  
*Twin-Screw Vise, Bench Dogs, Wonder Pups, Bench Bolts*

**Rockler**  
800-279-4441  
www.rockler.com  
*Jorgensen Vise, Twin-Screw Vise, Wonder Pups*

**Woodcraft**  
800-225-1153  
www.woodcraft.com  
*Jorgensen Vise, Twin-Screw Vise*

**Woodsmith Store**  
800-835-5084  
*Jorgensen Vise, Bench Dogs, Wonder Pups*

## ShopNotes

- "Online Extras" - Plans, Patterns, & More
- Over 100 Woodworking Tips Online
- Forums for Woodworking, Tools, & Classifieds
- Visit Our Woodworking Shop Tours Gallery
- Project Plans You Can Download
- Catalog of Project Kits, Tools, Jigs, & Plans
- Links to Other Woodworking Sites
- Order *ShopNotes* & *Woodsmith* Back Issues

### Online Customer Service

Click on Subscriber Services at [www.shopnotes.com](http://www.shopnotes.com)

- Access your account status
- Change your mailing or email address
- Pay your bill
- Renew your subscription
- Tell us if you've missed an issue
- Find out if your payment has been received

[www.shopnotes.com](http://www.shopnotes.com)

## Scenes from the Shop

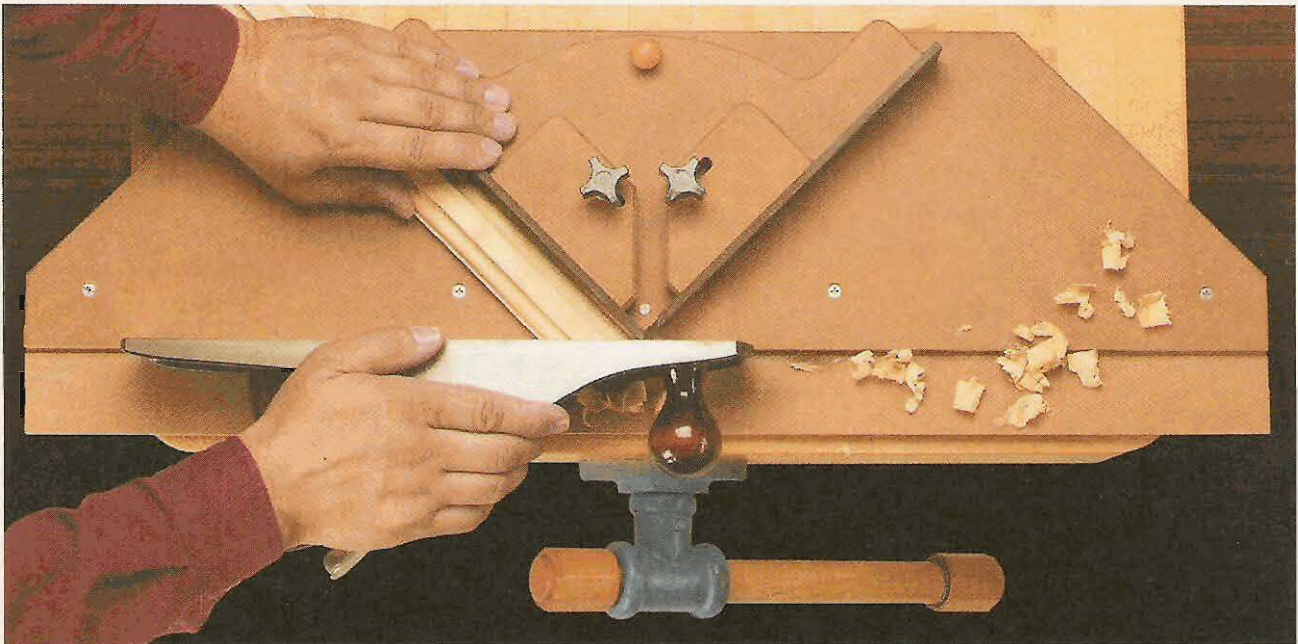

▲ Planing a paper-thin shaving from the end of a mitered workpiece is easy with the shop-made shooting board shown above. Sliding fences provide support

right to the end of the miter. And because the stop block is adjustable, you can also plane the end of a workpiece perfectly square. Detailed plans begin on page 12.

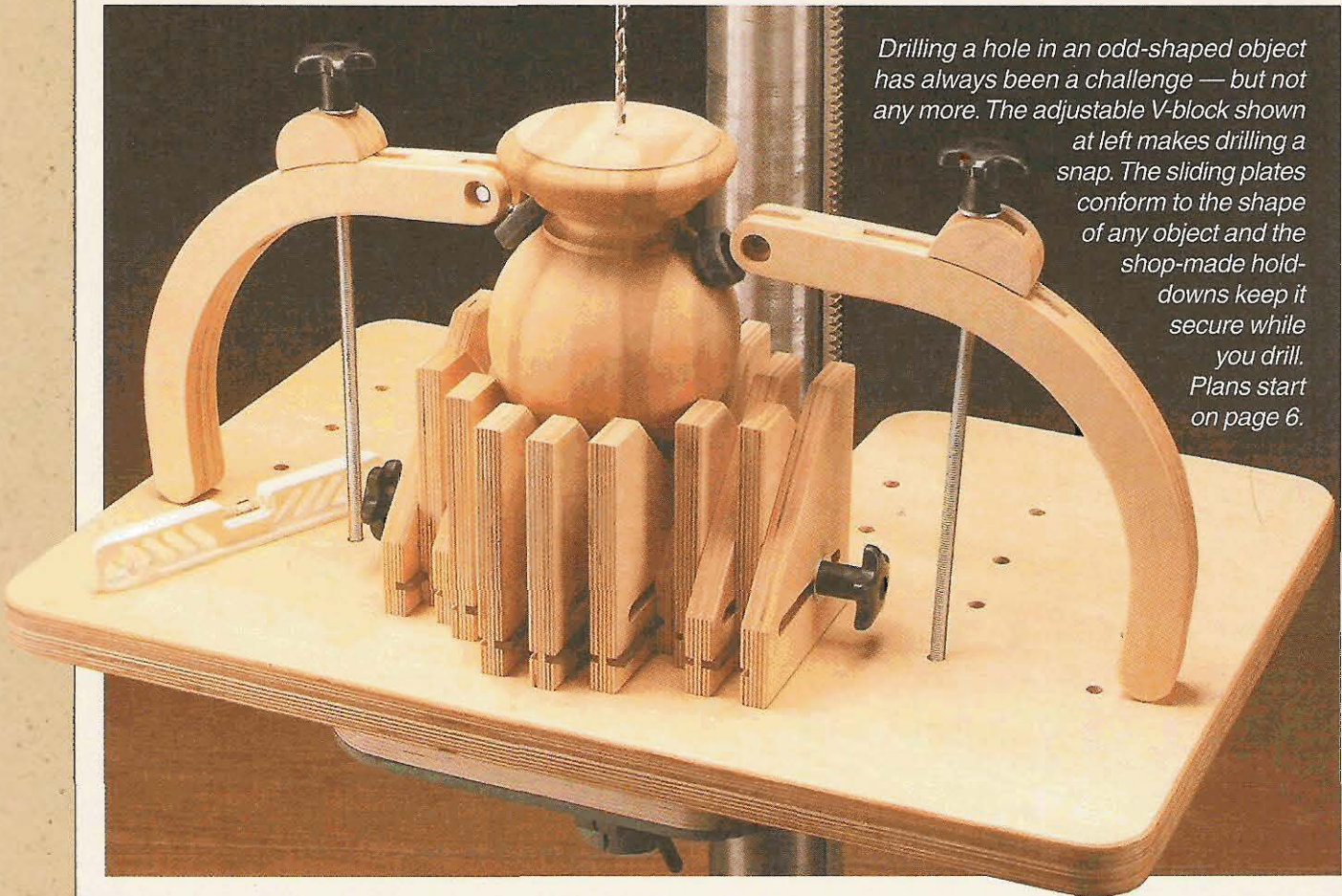

Drilling a hole in an odd-shaped object has always been a challenge — but not any more. The adjustable V-block shown at left makes drilling a snap. The sliding plates conform to the shape of any object and the shop-made hold-downs keep it secure while you drill. Plans start on page 6.

Twin Screw  
**Heavy-Duty  
Workbench**

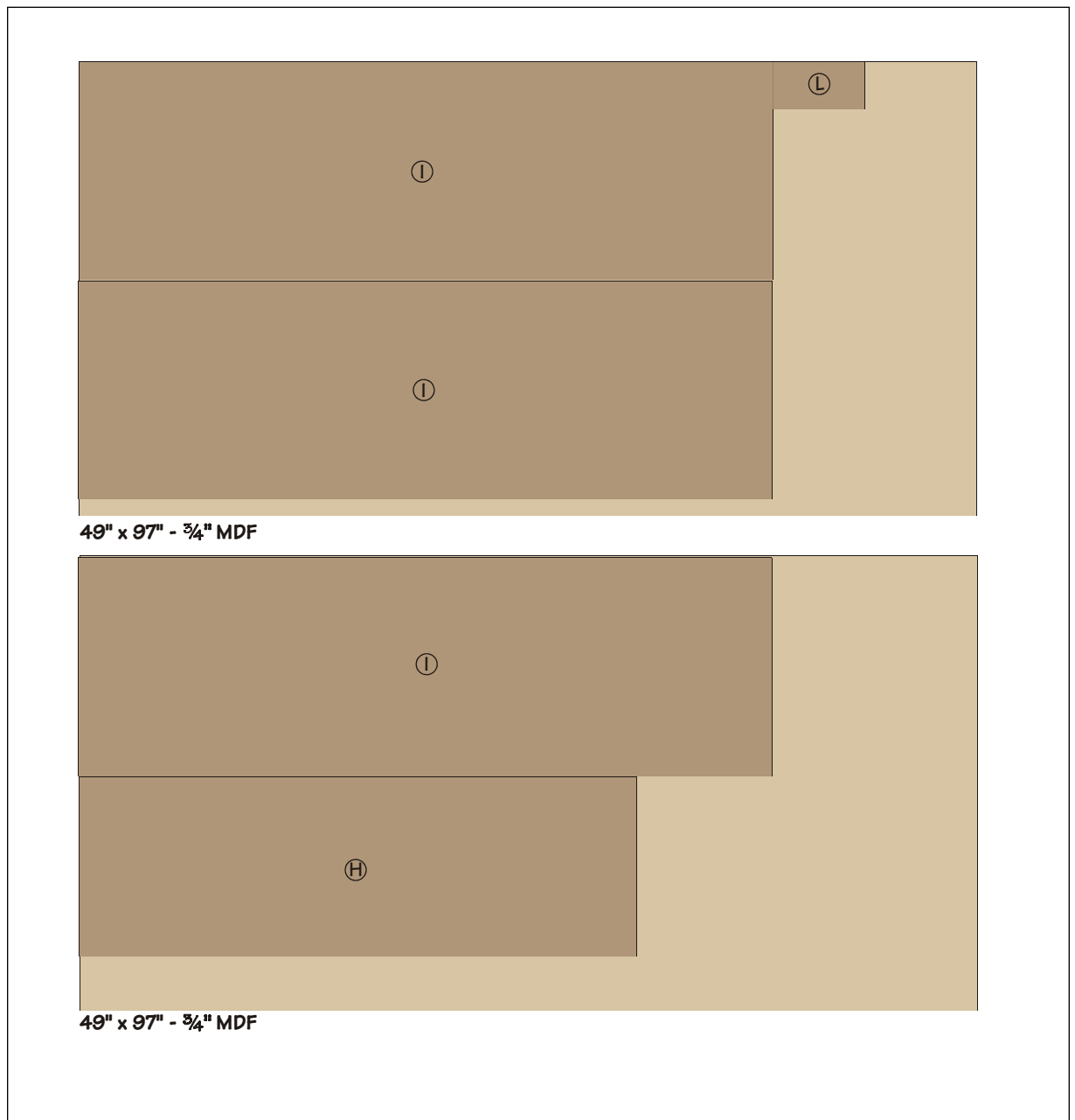

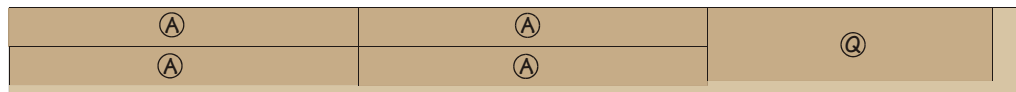

1 3/4" x 8" x 96"

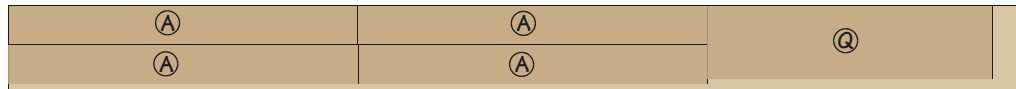

1 3/4" x 8" x 96"

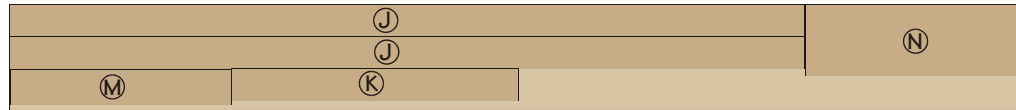

1 3/4" x 10" x 96"



1 3/4" x 8" x 96"



1 3/4" x 8" x 96"



3/4" x 8" x 72"

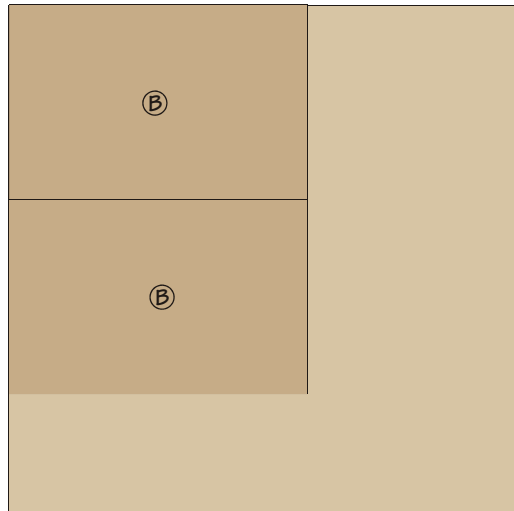

48" x 48" - 3/4" PLYWOOD

**NOTE:**

Ⓢ Made From Scrap Piece

## Materials & Hardware

### Base

A Legs (4)	3 1/2 x 32 3/4 - 3 1/2
B End Panels (2)	18 3/8 x 28 1/4 - 3/4 Ply.
C Filler Strips (4)	1 x 4 1/2 - 3/4
D Narrow Upper Rail (1)	4 1/2 x 16 3/8 - 3/4
E Wide Upper Rail (1)	5 1/4 x 16 3/8 - 3/4
F Lower Rails (2)	7 x 16 3/8 - 3/4
G Stretchers (2)	7 x 57 3/4 - 1 3/4
H Shelf (1)	19 3/8 x 60 1/2 - 3/4 MDF

### Top

I Top Layers (3)	23 1/2 x 75 - 3/4 MDF
J Front/Back Aprons (2)	3 x 75 - 1 3/4
K End Apron (1)	3 x 27 - 1 3/4

### Front Vise

L Spacer Block (1)	4 1/2 x 10 - 3/4 MDF
M Backing Plate (1)	3 3/4 x 20 - 1 3/4
N Face Block (1)	6 3/4 x 20 - 3 1/2

### Twin-Screw End Vise

O Wide End Apron (1)	6 3/4 x 27 - 1 3/4
P Apron Braces (2)	3 3/4 x 12 - 1 3/4
Q Twin-Screw Face Block (1)	6 3/4 x 27 - 3 1/2
R Rub Plates (2)	2 1/2 x 4 - 1
S Cleats (2)	1 1/4 x 16 3/8 - 3/4

# Drill Press Adjustable V-Block

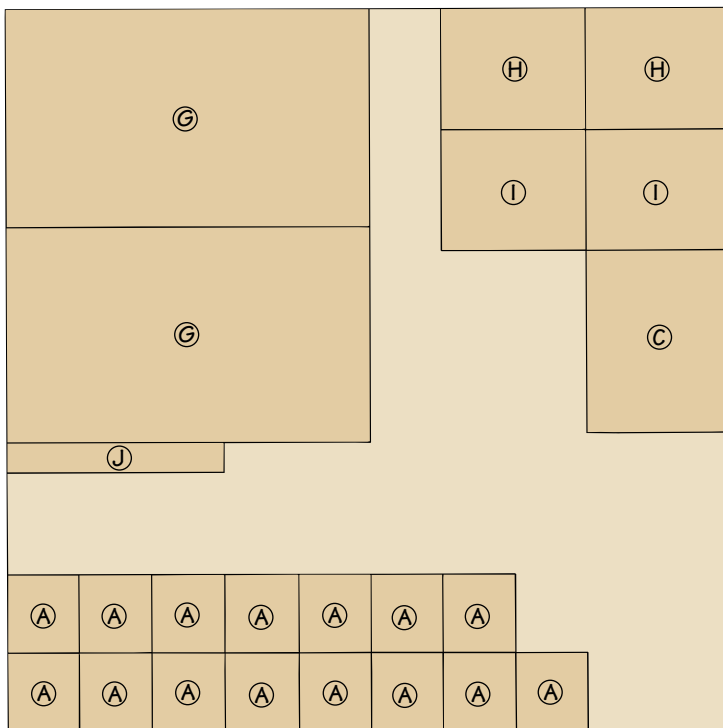

60" x 60" - 3/4" PLYWOOD

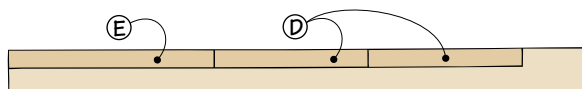

3 1/2" x 48" - 3/4" HARDWOOD

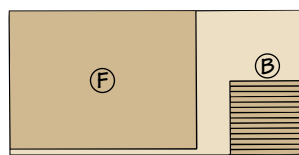

12" x 24" - 1/4" HARDBOARD

## Materials

### V-Block

- A Plates (15) 6 1/2 x 6 - 3/4 Plywood
- B Splines (14) 7/16 x 6 - 1/4 Hardboard

### Alignment Jig

- C Base (1) 12 x 15 5/16 - 3/4 Plywood
- D Side Rails (2) 3/4 x 1 1/2 - 12 3/4
- E Back Rail (1) 3/4 x 1 1/2 - 16 13/16
- F Alignment Plate (1) 11 1/2 x 15 1/4 - 1/4 Hardboard

### Table

- G Table (1) 20 x 30 - 1/2 Plywood

### Hold-Downs

- H Tall Hold-Downs (2) 10 x 12 - 1 1/2 Plywood
- I Short Hold-Downs (2) 4 1/2 x 10 1/16 - 1 1/2 Plywood
- J Clamp Pads (4) 2 1/2 x 1 5/16 - 1 1/2 Plywood