

TIPS • TOOLS • TECHNIQUES

# ShopNotes®

Vol. 7

Issue 38

SPECIAL LATHE PROJECT:

## Ring Boxes

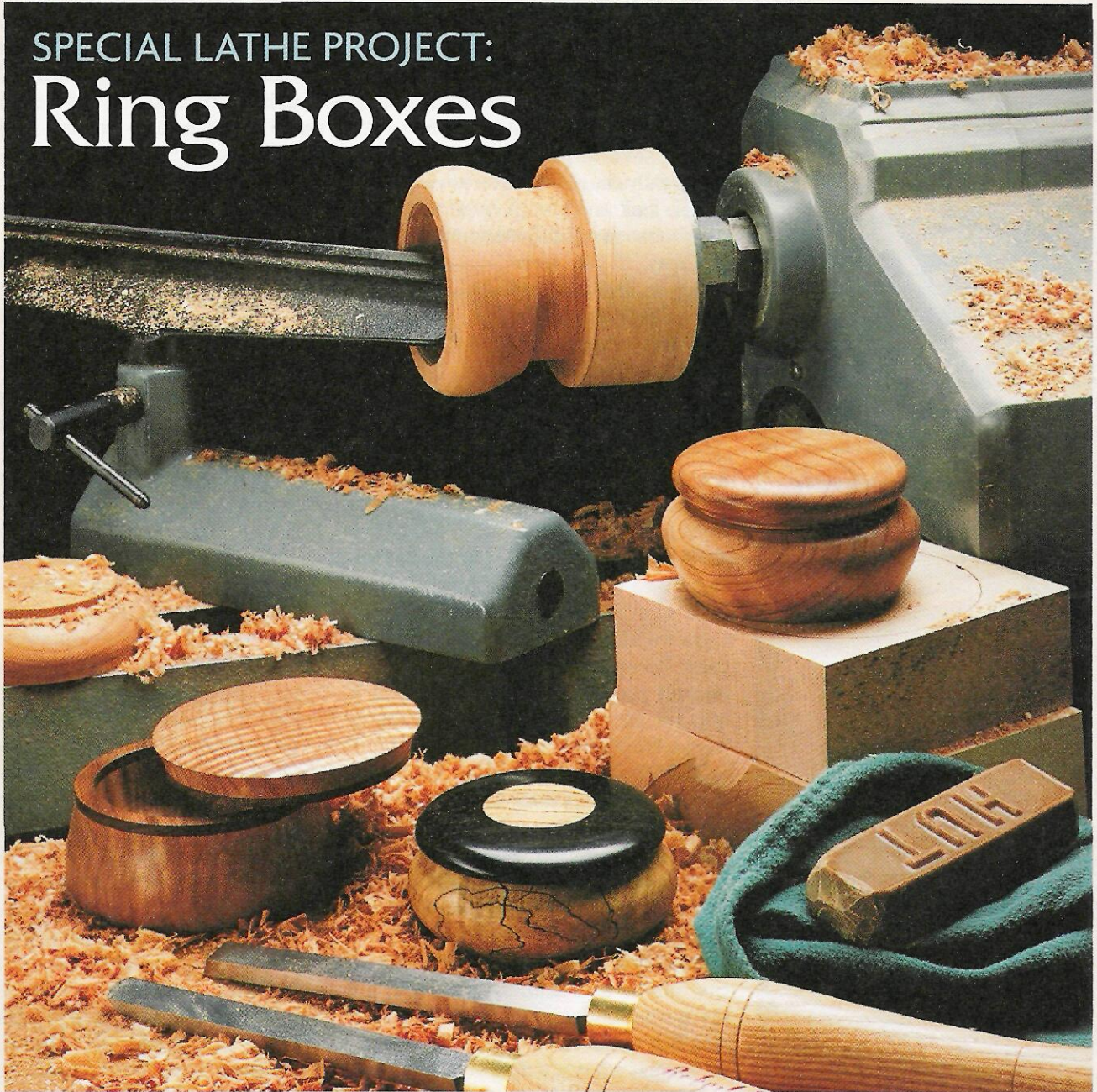

- Adjustable Planer Jig
- Using Lathe Scrapers
- Air-Drying Lumber
- Benchttop Drill Press Stand



# ShopNotes®

Issue 38

March 1998

**PUBLISHER** Donald B. Peschke  
**EDITOR** Tim Robertson  
**ASSISTANT EDITOR** Bryan Nelson  
**ART DIRECTOR** Cary Christensen  
**SR. GRAPHIC DESIGNER** Kurt Schultz  
**SENIOR ILLUSTRATORS** Roger Reiland  
 Mark Higdon

### CREATIVE RESOURCES

*Creative Director:* Ted Kralicek • *Project Developer:* Ken Munkel • *Project Designers:* Ted Wong, Kevin Boyle • *Project Coordinator:* Kent Welsh • *Shop Mgr.:* Steve Curtis • *Shop Craftsman:* Steve Johnson • *Photography Director:* Lark Smothermon • *Sr. Photographer:* Crayola England

### BOOKS

*Executive Editor:* Douglas L. Hicks • *Art Director:* Linda F. Vermie • *Sr. Graphic Designer:* Chris Glowacki

### CIRCULATION

*Sub. Serv. Dir.:* Sandy Baum • *New Bus. Dir.:* Glenda Battles • *Renewal Mgr.:* Paige Rogers • *Billing Mgr.:* Rebecca Cunningham • *Asst. Sub. Mgr.:* Joy Krause • *Promotion Mgr.:* Rick Junkins • *Single Copy Mgr.:* Todd L. Bierle • *Assoc. Graphic Design Dir.:* Susie Rider • *Sr. Graphic Designer:* Cheryl L. Simpson

### CORPORATE SERVICES

*VP of Planning & Finance:* Jon Macarthy • *Controller:* Robin Hutchinson • *Sr. Acct.:* Laura Thomas • *Accts. Payable:* Mary Schultz • *Accts. Receivable:* Margo Petrus • *Prod. Dir.:* George Chmielarz • *Elect. Pub.:* Douglas M. Lidster • *Prod. Asst.:* Susan Dickman • *Pre-Press Image Spec.:* Troy Clark • *New Media Mgr.:* Gordon C. Gaippe • *Multimedia Art Dir.:* Eugene Pedersen • *Net. Admin.:* Al Barnes • *I.S. Support Asst.:* Chris Harrison • *H. R. Asst.:* Kirsten Koele • *Admin. Asst.:* Julia Fish • *Recept.:* Jeanne Johnson, Sheryl Ribbey • *Bldg. Maint.:* Ken Griffith • *Special Proj. Dir.:* Saville H. Inman

### MAIL ORDER

*Operations Dir.:* Bob Baker • *Mat'l's Mgr.:* Mark Mattiussi • *Cust. Service Mgr.:* Jennie Enos • *Warehouse Supervisor:* Nancy Johnson • *Buyer:* Linda Jones • *Op. Asst.:* Tammy Aldini • *Team Leader:* Karla Eslinger • *Tech. Rep.:* Matthew TeRonde • *Customer Service Reps.:* Anna Cox, Tammy Truckenbrod, Adam Best, Nancy Downey, Deborah Rich • *Warehouse:* Nancy Connelley, Sylvia Carey • *Quality Control Tech.:* Frank Johnson

ShopNotes® (ISSN 1062-9696) is published bimonthly (Jan., March, May, July, Sept., Nov.) by August Home Publishing, 2200 Grand, Des Moines, IA 50312.

ShopNotes® is a registered trademark of August Home Publishing ©Copyright 1997 by August Home Publishing. All rights reserved.

**Subscriptions:** Single copy: \$4.99. One year subscription (6 issues), \$24.95. Canada/Foreign add \$5 per year.

**Periodicals Postage Paid** at Des Moines, IA, and at additional mailing offices.

**Postmaster:** Send change of address to ShopNotes, P.O. Box 37103, Boone, IA 50037-2103.

**Subscription Questions?** Write to: ShopNotes Customer Service, P.O. Box 842, Des Moines, IA 50304-9961. Or call 1-800-333-5854, 8:00 am to 5:00 pm, Central Time, weekdays. FAX 515-283-0447

**E-Mail:** ShopNotes@shopnotes.com

**Internet:** http://www.shopnotes.com

PRINTED IN U.S.A.

## WoodNet™

### NOW ON THE WEB!

- 50 Woodworking Tips Online
- Woodworking Techniques — Step-by-Step
- Project plans you can download
- WoodNet Forum — Woodworkers' Q & A
- Power Tool Reviews

Point your browser to: <http://www.augusthome.com>  
 Select "Woodworking" from the Welcome Page menu.

Reprinted 2002

# Cutoffs

One question I often get asked is, "Why don't you guys at ShopNotes feature more turning projects and techniques for the lathe?"

Well, to be perfectly honest, I don't have that much experience working on a lathe. So up to now, I've been just a bit hesitant to tackle a lathe project.

However, Bryan (our assistant editor), is pretty good on a lathe. In fact, he's turned several projects recently that have really caught my interest. But they either look too complicated. Or they require too many different turning tools.

"Okay, if you were going to include just one simple project in an issue, what would it be?" I asked.

"How about a small hand mirror that slips into a lady's purse?" he said. So we decided to give it a try.

The mirror was simple enough. We turned a basic disk, scooped out a shallow recess, and glued in the mirror. But there was still something about it that wasn't quite right.

So we showed the mirror to Jeanne (our receptionist). She said, "The biggest problem with that mirror is it will get all scratched up in a woman's purse. How about adding a cover?"

That sounded like a great idea. And it didn't take us long to turn a cover for the mirror. But when we put the two pieces together, they resembled a hamburger bun more than a mirror. Fortunately, the project was about to take a "turn" for the better.

**RING BOX.** Jeanne took one look at the mirror and said, "It's too big for my purse, but you could make a nice ring box out of it."

"So just what is a ring box?" I asked. "You know, it's a small box that

holds rings and pieces of jewelry. And usually the box has a lid so you can hide your treasures inside."

That's when the light bulb finally lit. A ring box sounded exactly like the type of project we were looking for.

**TWO TOOLS.** As it turns out, it was far easier to turn a ring box than I ever imagined. In fact, the base of the box and the lid can be turned with two basic tools: a scraper and a parting tool. (See page 10 for tips on using a scraper.)

**FINISH.** Not only that, you can accomplish the entire project (from

*Experiment a little. Have some fun. And let the shavings fly.*

initial shaping to the final application of the finish) while it's still on the lathe. (We've also included an article

about finishing on a lathe, see page 28.)

**JAM CHUCKS.** But there is one thing that might stump you when turning a ring box. It has to do with turning the bottom of the box.

The problem is the bottom is turned after you've scooped out the insides of the box. But if the box is hollowed out like a pumpkin, how do you remount it on the lathe? The solution is a simple "jam" chuck turned from a block of wood. (For more on this, see page 29.)

**EXPERIMENT.** As you can see, I'm excited about these ring boxes. They provide a great opportunity to experiment with different types of wood. In fact, we used several pieces of highly figured wood we've been saving for just the right project, refer to page 12.

Regardless of the type of wood you use, don't be afraid to experiment a little with the basic shape. Just a subtle change can have a dramatic effect in the appearance of the box.

So have some fun with this project. And let the shavings fly.

*Tim*

# Contents

## Techniques

### Lathe Scrapers \_\_\_\_\_ 10

*A simple burr. That's the secret to getting crisp, clean cuts with a scraper when turning a project on the lathe.*

### Logs to Lumber \_\_\_\_\_ 24

*There may be a great source of inexpensive lumber in your own backyard. Here's one woodworker's story.*

### Finishing on a Lathe \_\_\_\_\_ 28

*The best time to apply a finish to a turning project is before you take it off the lathe. We show you how.*

### Making a Jam Chuck \_\_\_\_\_ 29

*You don't need a special chuck to mount a project to the lathe. Just fit it onto a "jam" chuck that you turn from scrap.*

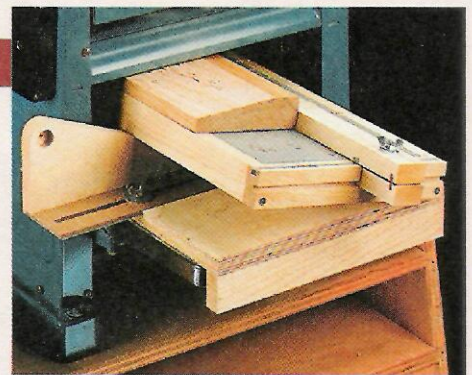

*Adjustable Planer Jig* page 6

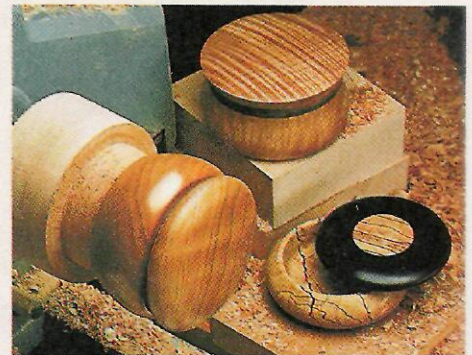

*Ring Boxes* page 12

## Projects

### Adjustable Planer Jig \_\_\_\_\_ 6

*A unique tilting table lets you bevel a workpiece safely and accurately using a portable thickness planer.*

### Turned Ring Boxes \_\_\_\_\_ 12

*Three simple ring boxes that can be turned from start to finish with just a scraper and a parting tool.*

### Drill Press Stand \_\_\_\_\_ 16

*This roll-around stand for your benchtop drill press features three pull-out trays to help organize all your drill bits and accessories.*

### Drill Press Table & Fence \_\_\_\_\_ 22

*Turn your drill press into a real woodworking tool with this simple table and adjustable fence.*

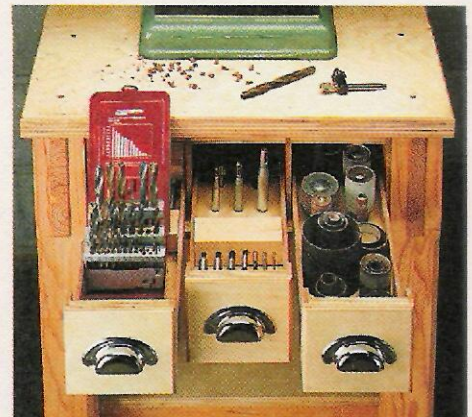

*Drill Press Stand* page 16

## Departments

### Readers' Tips \_\_\_\_\_ 4

*Our readers offer their own shop-tested tips.*

### Shop Solutions \_\_\_\_\_ 30

*Handy tips and techniques from our own shop.*

### Sources \_\_\_\_\_ 31

*Hardware, supplies, and mail order sources.*

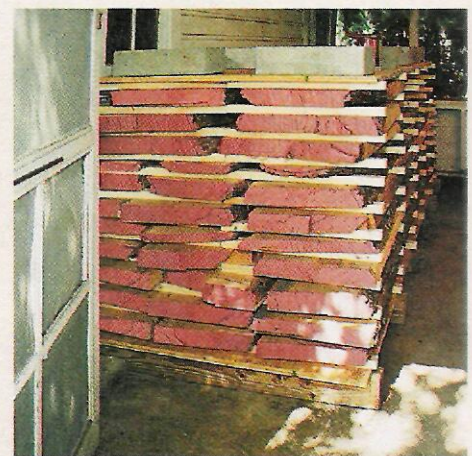

*Logs To Lumber* page 24

# Readers' Tips

## Shop-Made Faceplate

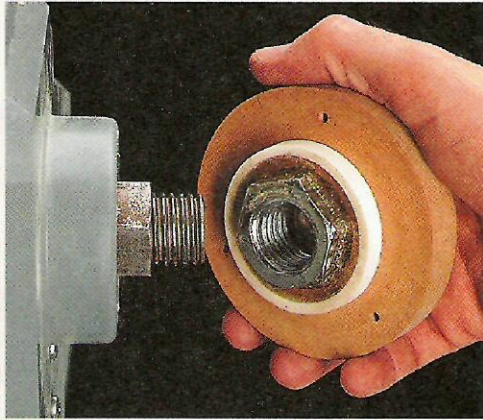

■ When turning a number of small bowls on the lathe, I use a separate faceplate for each one. This lets me turn each bowl to rough shape and remove it from the lathe without taking it off the faceplate.

That way, if the movement of the wood distorts the shape of the bowl, I don't have to worry about remounting it on a faceplate (and getting it perfectly centered). Instead, I just thread the faceplate back on the lathe and turn the bowl to final shape.

But rather than buy new faceplates, I make my own shop-made

versions. Each one is a 3"-dia. disk (MDF) with a counterbore to accept a nut, see drawing. (Just be sure the threads on the nut match those of the spindle on the lathe.)

The nut is held in place with epoxy. To help the epoxy "grab," I filed shallow grooves in the nut, see detail. And a short ring of PVC pipe forms a dam to keep the epoxy from running out, see Fig. 1.

Finally, drill mounting holes in the faceplate and true up the face and edge on the lathe, see Fig. 2.

*Douglas Bernier*

*Marlinton, West Virginia*

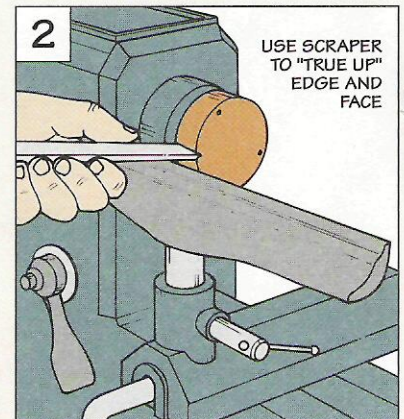
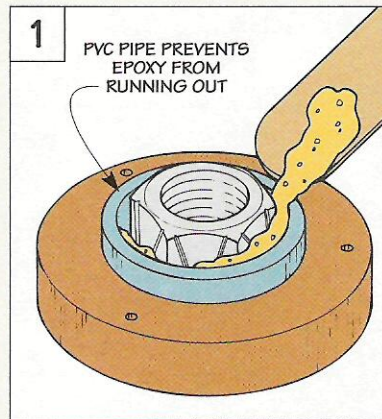
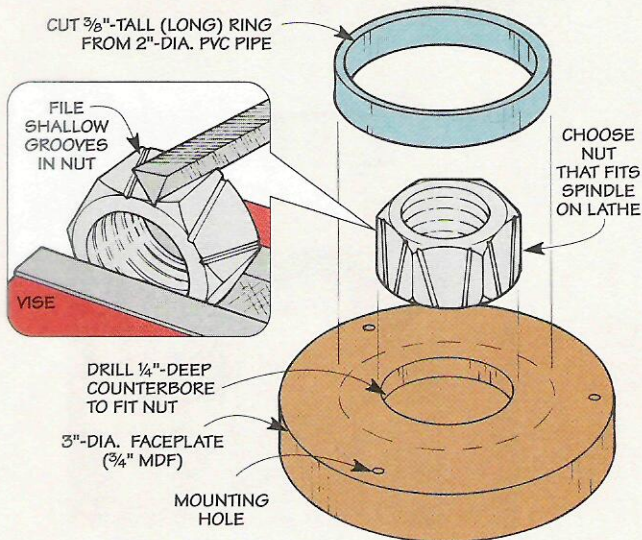

## Drill "Holster"

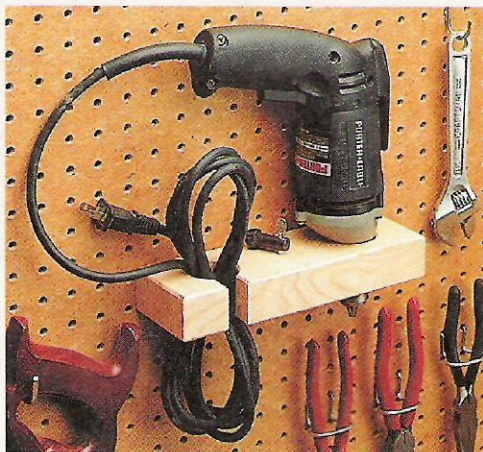

■ Here's a handy way to store your electric drill — a "holster" that hangs on a pegboard rack.

The holster is a scrap of "two-by" material with two openings cut in it. The drill chuck fits in a large hole. And the power cord slips into a keyhole-shaped notch, see drawing.

By installing two L-hooks in the back edge, you can hang the holster securely on the pegboard.

*Dick Grote*

*Palo Alto, California*

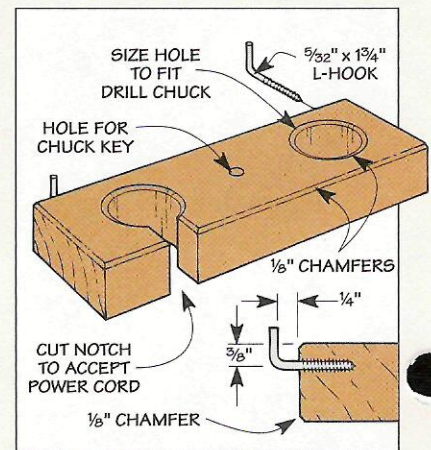

## Quick Tips

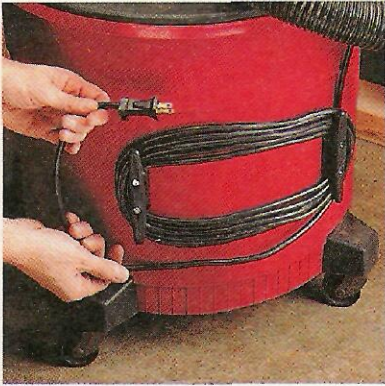

▲ A pair of rope cleats bolted to his shop vacuum make it easy for **Richard Meure** of Redwood City, CA to store the power cord.

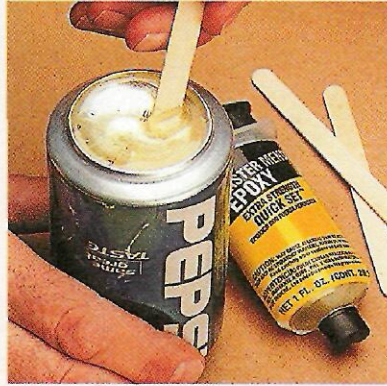

▲ To mix epoxy without a mess, **Harvey Klotz** of Austin, TX uses the bottom of a soft drink can as a "well" and a popsicle stick as a scraper.



▲ A quick "snap" is all it takes for **Robert Gordon** of Bowie, MD to set the head of a small brad. He just uses a spring-loaded punch.

## Dowel Storage

■ Like many woodworkers, I keep several different size dowels on hand. To provide easy access to the one I need, I made a simple storage rack.

The rack consists of three pieces of PVC pipe that "stairstep" up in height (10", 22", and 34" in

my case), see photo. If a dowel is too short to stick out the top of a pipe, it's still visible through a "window" in front.

When cutting this window (I used a bandsaw), it's a good idea to clamp the pipe to a scrap to keep it from rolling, see Figs. 1 and 1a.

To complete the rack, just glue the pipes together with PVC cement and add an end cap in the bottom of each one, see Fig. 2. Screwing the center pipe to a wall stud holds the rack in place.

*Norman Crowfoot  
Tucson, Arizona*

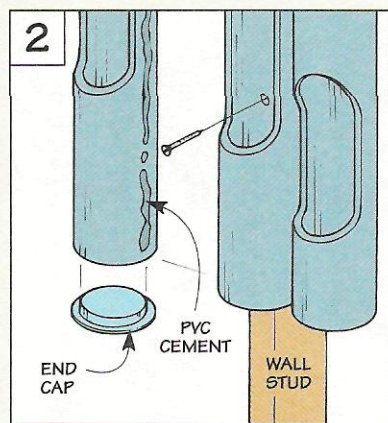
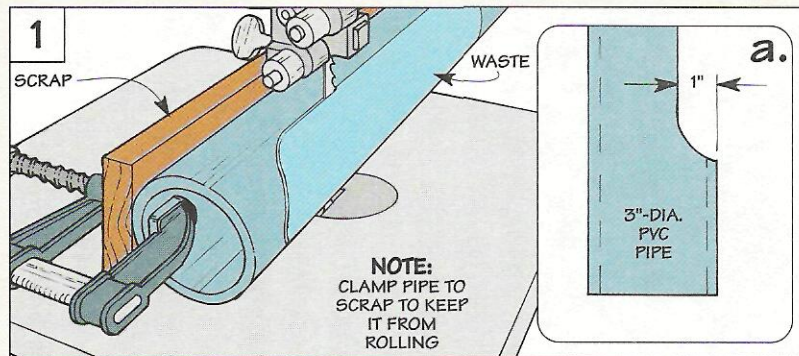

### Send in Your Tips

To share your original tips and solutions to problems you've faced, send them to: *ShopNotes*, Attn.: Readers' Tips, 2200 Grand Ave., Des Moines, IA 50312. (Or if it's easier, FAX them to us at: 515-282-6741.)

We'll pay up to \$200 depending on the published length. Please include a daytime phone number so we can call you if we have any questions.

# Adjustable Planer Jig

You can make a beveled cut safely and accurately using this simple jig and a portable thickness planer.

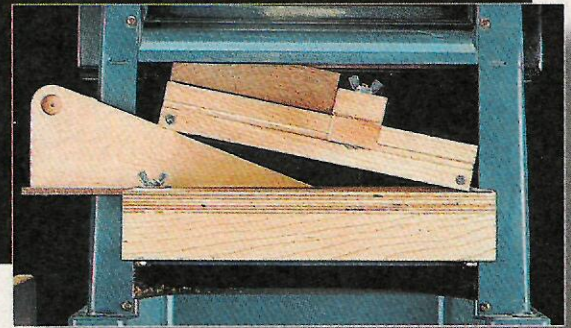
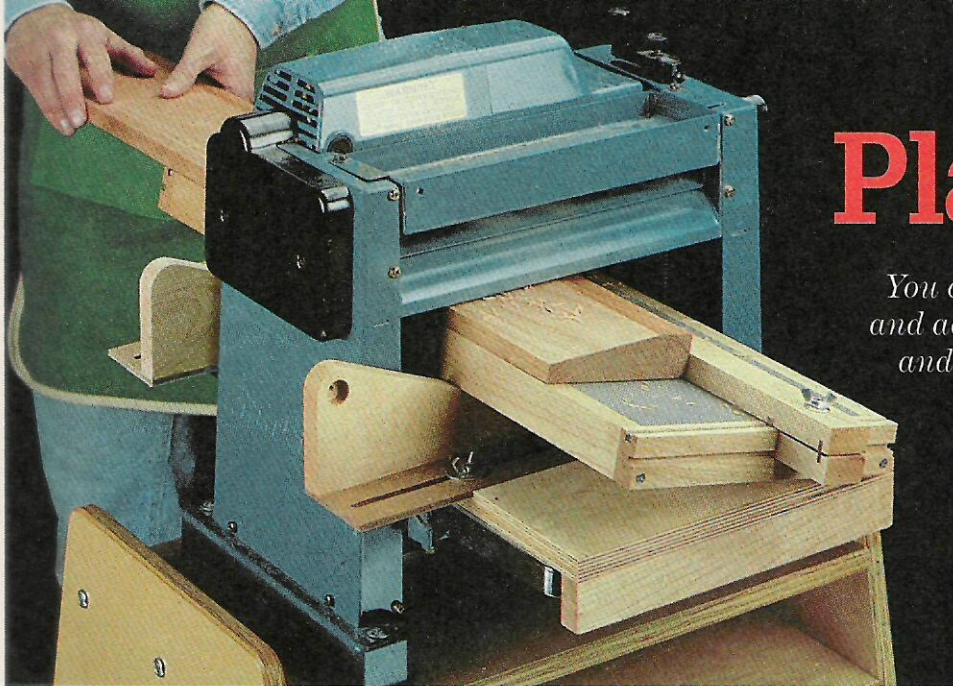

## Hardware

- (10) #8 x 1 1/2" Fh Woodscrews
- (6) #8 x 3/4" Fh Woodscrews
- (2) 1/4" x 1" Fh Machine Screws
- (2) 1/4" Flat Washers
- (2) 1/4" I.D. x 1 1/4" O.D. Fender Washers
- (4) 1/4" Wing Nuts
- (2) 1/4" x 10" (rgh.) Threaded Rod
- (2) 1/4" x 1 1/2" Threaded Rod
- (1) 1 1/2" x 25" Plano Hinge w/Screws
- (2) 1/4" x 2" Carriage Bolts

**M**aking a beveled cut on the edge of a workpiece is a fairly straightforward process — at least in theory. You just tilt the rip fence, and push the workpiece through on its edge.

But in practice, it's not that simple. First, there's quite a bit of the saw blade exposed. And that makes me nervous (espe-

cially if I'm cutting a *wide* bevel). Also, there are always saw marks left behind that are a pain to remove.

To solve both problems, I made a simple jig. Not for the table saw like you might expect. Instead, it's designed to be used with a portable thickness planer so you can *plane* a bevel on the workpiece, see photo.

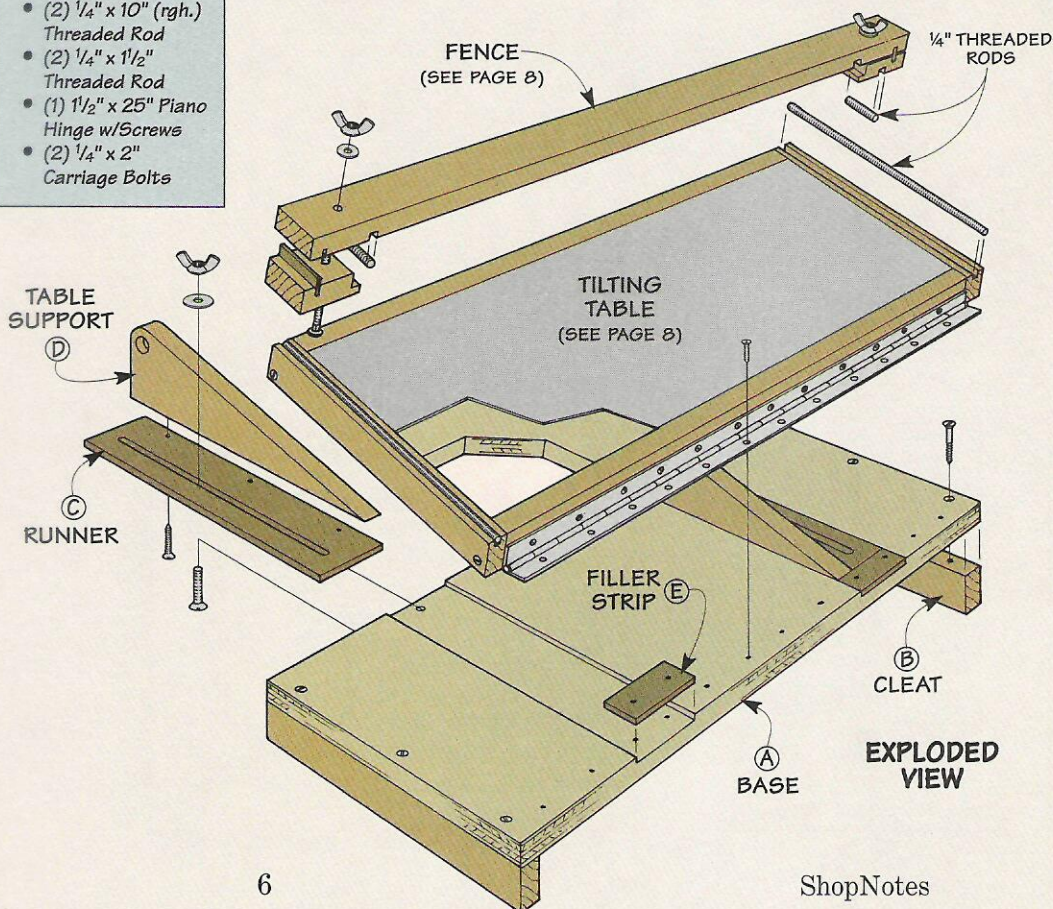

**TILTING TABLE.** The key to making this work is a tilting table that supports the workpiece at an angle, see inset photo. As the piece slides across the table, the planer blades cut a crisp, clean bevel up to 8 1/2" wide. And my hands remain safely out of the way.

**BASE.** I began by making a plywood base, see drawing at left. It serves as a mounting platform for the tilting table. And it provides a track for two wedge-shaped supports used to adjust the angle of the table.

In use, the base hooks over the ends of the infeed/outfeed tables on the planer. This way, the jig won't get pulled through the planer when making a cut.

To accomplish this, the *base* (A) is cut to width so it fits snug inside the planer, see Fig. 1. And it's 1 1/2" longer than the combined length of the bed and the infeed/outfeed tables. This way, you can add a 3/4"-thick hardwood *cleat* (B) to each end that butts against the end of the tables and holds the base in place.

## TABLE SUPPORTS

After attaching the cleats with glue and screws, you can turn your attention to the wedge-shaped table supports.

These supports do a couple of things. First, they slide in and out of the base so you can adjust the angle of the table. Second, they prevent the pressure of the feed rollers from deflecting the table when making a cut.

**DADOES.** To adjust the angle of the table, each support is attached to a runner that slides in a dado in the base, see Fig. 1. The idea is to locate the *inside* shoulder of these dadoes so the table supports end up  $\frac{1}{4}$ " outside the housing of the planer, see detail in Fig. 1. This way, the supports won't bump into the planer as you slide them in and out.

**RUNNERS.** Now the two *runners* (C) can be cut to fit the dadoes, see Fig. 2. These are pieces of  $\frac{1}{4}$ " hardboard with an adjustment slot cut in each one. Note: Attaching strips of sandpaper to the bottom of the runners will keep them from slipping when they're tightened down.

**SUPPORTS.** With the runners complete, I added the wedge-shaped *table supports* (D), see Fig. 2. The exact angle of the supports isn't critical. But it should be the same on both pieces.

So I carpet-taped two  $\frac{3}{4}$ "-thick hardwood blocks together and used a bandsaw to cut them both at the same time. While I was at it, I knocked off the top corner. After drilling a counterbore in this corner to use as a finger pull, the supports are simply glued and screwed to the runners.

At this point, it's just a matter of adding a machine screw and wing nut to tighten the runner against the base, see Fig. 3. To prevent the screw from spinning, the head is epoxied into a countersunk shank hole drilled in the base, see Fig. 3a.

**FILLER STRIPS.** Finally, to provide a continuous surface for a hinge (added later), I cut two *filler strips* (E) to fit the openings at the end of the dadoes. They're simply glued in place.

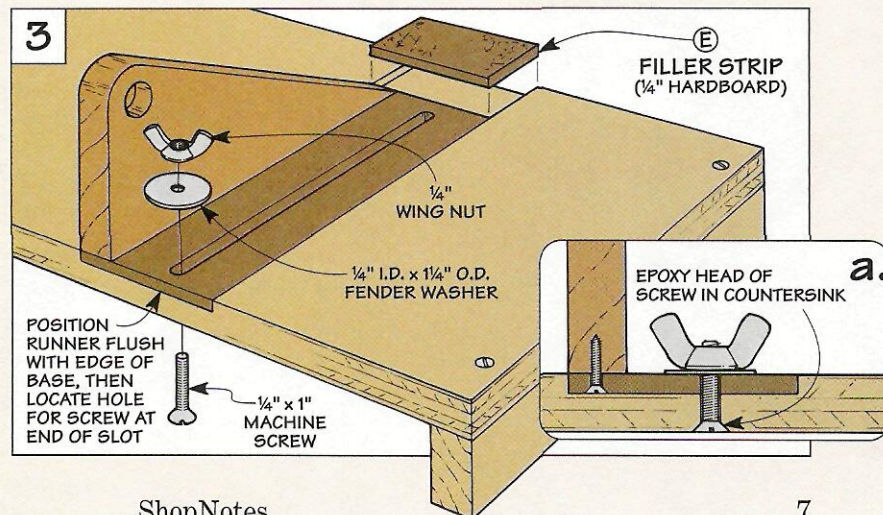
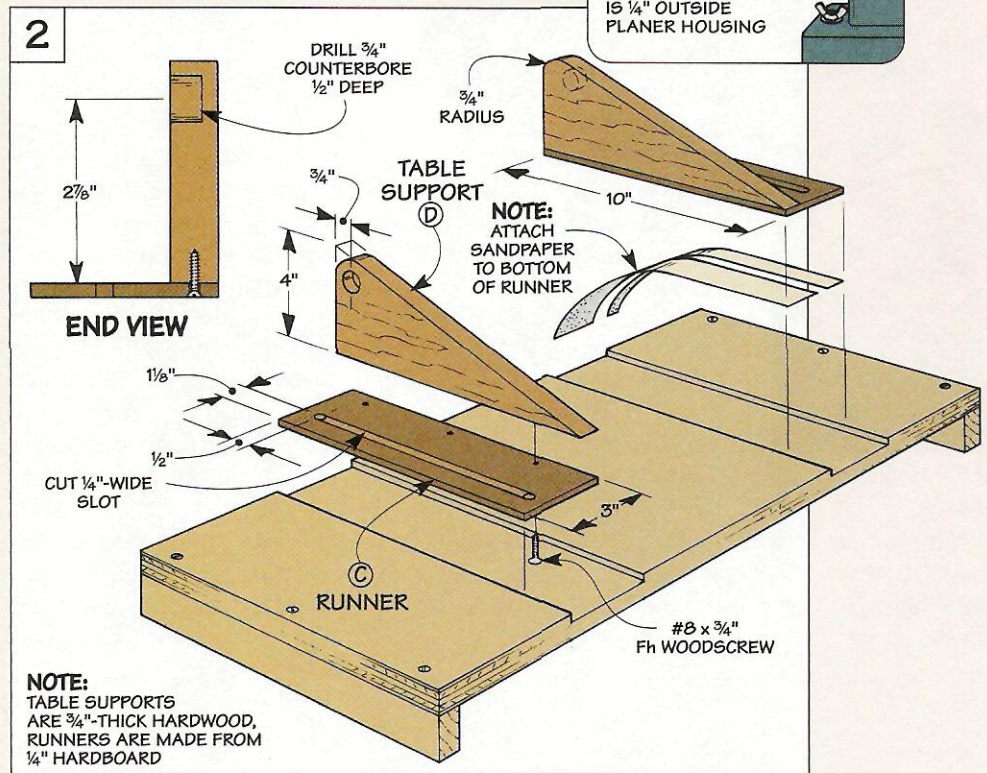
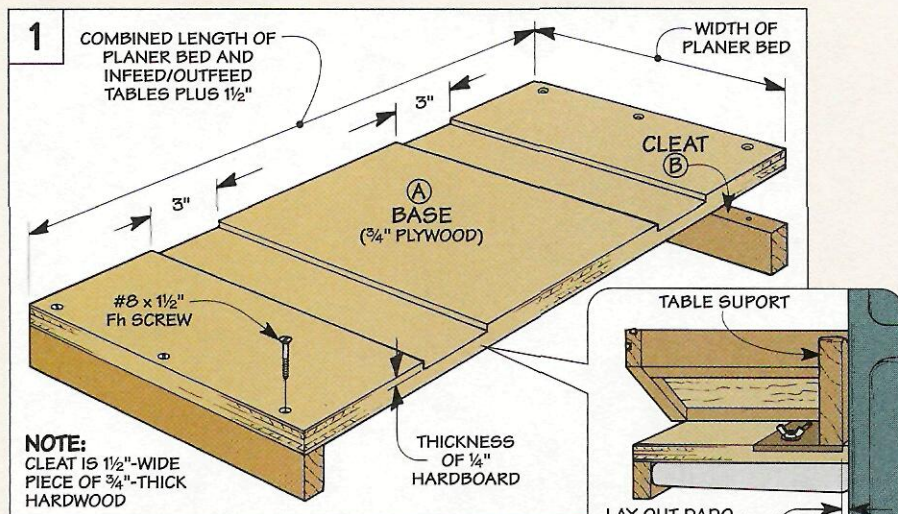

# Table & Fence

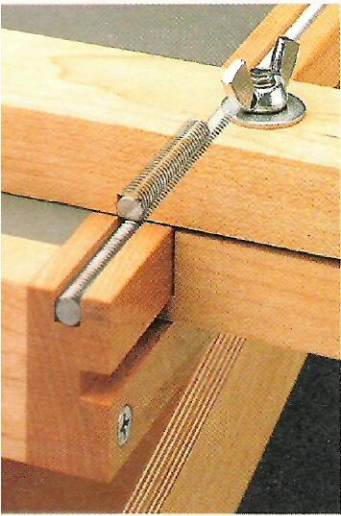
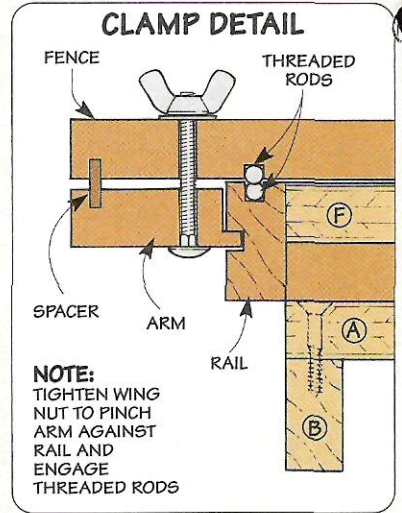
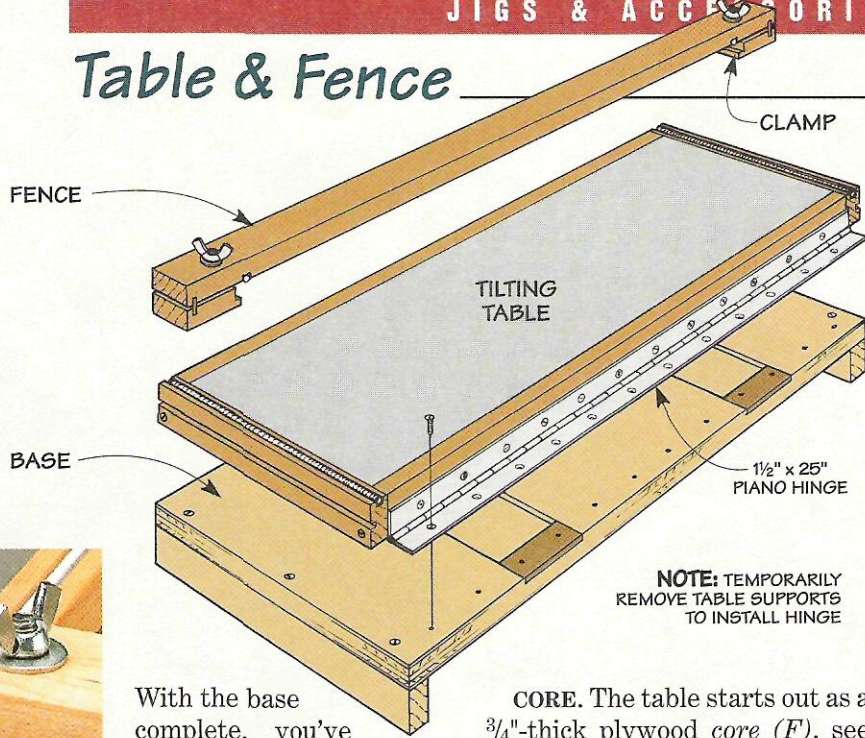

With the base complete, you've laid a solid foundation for the tilting table and fence. The table supports the workpiece at an angle as you feed it through the planer. And the fence guides it across the table.

## TILTING TABLE

By holding the workpiece at an angle to the cutterhead, the tilting table establishes the desired bevel. In addition, it houses part of a system that locks the fence in place, see margin at left.

▲ The secret to this no-slip fence is a pair of threaded rods that mesh together when you tighten the fence.

**CORE.** The table starts out as a 3/4"-thick plywood core (F), see Fig. 4. The length of the core is identical to the base. But it's 3 1/2" narrower. This will provide clearance on one side for a hinge. And on the other side, it gives you some knuckle room when adjusting the table supports.

**PLASTIC LAMINATE.** After cutting the core to final size, I applied plastic laminate to the top. (I used contact cement.) The laminate creates a slick surface that allows a workpiece to slide smoothly across the table.

**EDGING.** In use, the table has to withstand a consider-

able amount of downward pressure from the feed rollers. So to add rigidity, I glued on two long strips of hardwood edging (G), see Fig. 4.

**RAILS.** With the edging in place, the next step is to add a hardwood rail (H) to each end. To create a track for a clamp (added later), there's a groove in the outside face of each rail. And a groove in the top edge accepts a threaded rod that's part of a clamping system for the fence.

One thing to be aware of is the depth of the groove that holds the threaded rod. To prevent the threads from scraping the workpiece as you feed it through the planer, the groove needs to be deep enough so the rod sits just below the surface of the table. (I cut a 9/32"-deep groove which recessed the rod 1/32".)

After cutting the groove, you can install the threaded rod. This is just a matter of applying a small amount of epoxy in the bottom of the groove and pressing in the rod. Note: To ensure the clamping system will work properly later, be careful not to get epoxy in the threads on top of the rod.

Now all that's left is to glue and screw the rails to the table. Once they're in place, the table is

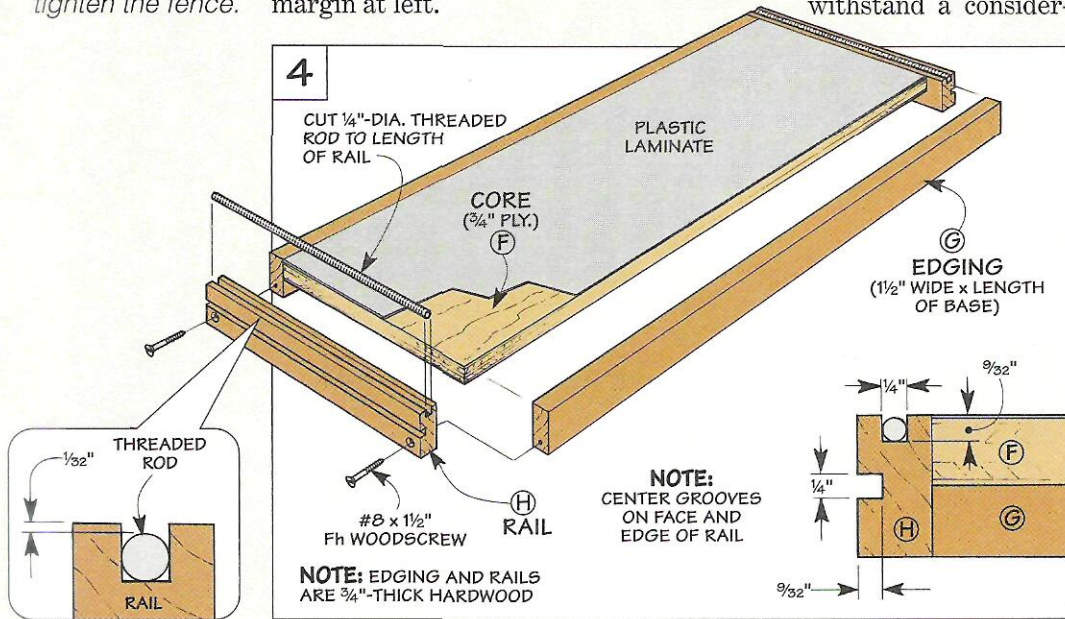

simply centered on the base and attached with a piano hinge, see drawing on page 8.

**FENCE**

With the table complete, the next step is to add the fence. Its job is to guide the workpiece across the table. Although that sounds simple, it's no small task.

Since the table is tilted at an angle, the pressure from the feed rollers tends to push the workpiece "downhill" (against the fence). If the fence slips even a small amount, the width of the bevel will vary from one end of the workpiece to the other.

So what keeps the fence from slipping? The secret is a short threaded rod installed in each end. As the fence is tightened, the threads on this rod interlock with the threads on the rod in the table. It's these interlocking threads that prevent the fence from creeping.

**FENCE.** The *fence (I)* is a narrow strip of hardwood that's 4" longer than the overall length of the table, see Fig. 5. (This creates an overhang at each end of the table for a clamp.)

A kerf in each end of the fence accepts a spacer (added later), see detail in Fig. 5. And you'll also need to cut a dado in each end for the threaded rod.

One thing to note about these dados is they're  $\frac{1}{16}$ " shallower than the diameter of the threaded

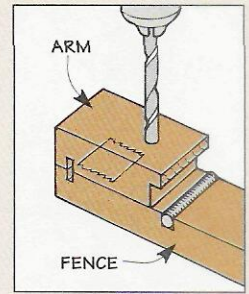
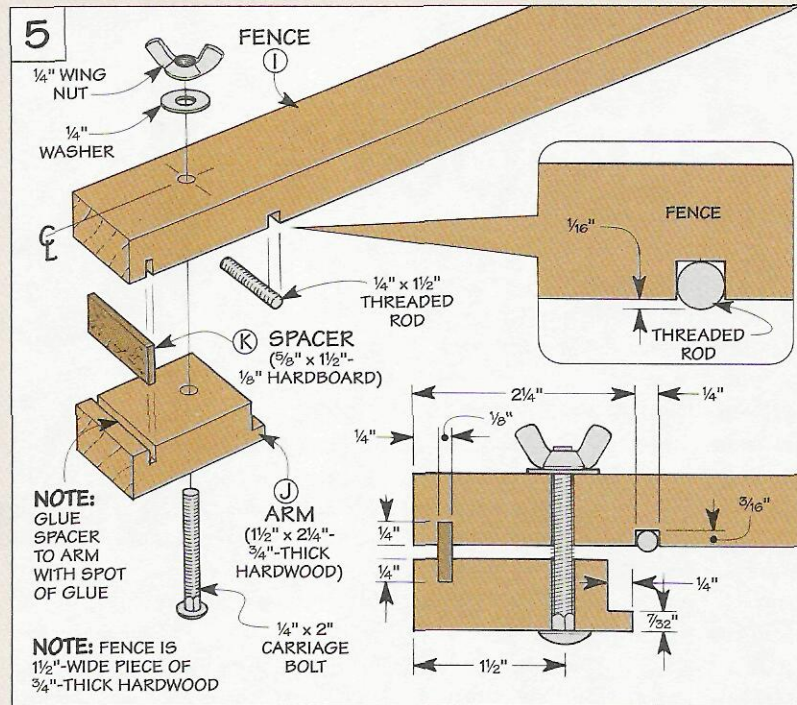

▲ Using carpet tape to temporarily attach the arm to the fence ensures proper alignment when you drill the holes.

rod. This way, the rod sits a bit "proud" so it can engage the rod in the table. Here again, the rod is held in place with epoxy.

**CLAMPS.** All that's left is to add a pair of clamps that secure the fence to the table. Each clamp consists of two parts: a hardwood *arm (J)* and a *spacer (K)* made of  $\frac{1}{8}$ " hardboard, see Fig. 5.

The way the clamp works is simple. The arm is rabbeted at one end to form a tongue that fits into the groove in the rail, see Clamp Detail on page 8. And a kerf near the opposite end accepts the spacer. *Safety Note:* It's best to make these cuts on a long blank

and then cut the arm to length.

The spacer forms a gap between the arm and the fence. This way, when the clamp is tightened, the arm pinches tightly against the rail. At the same time, this pressure engages the threaded rods which locks the fence in place.

To provide this clamping pressure, a wing nut is tightened on a carriage bolt that passes through holes in the arm and the fence. Just be sure the holes align, see margin.

**SETUP.** After assembling the clamps, it only takes a minute to set up the jig, see Steps 1 and 2 below. Then just make a series of light passes to cut the bevel. 🛠️



**1** Use a scrap with the desired bevel marked on the end to establish the angle of the table. Then slide in the table supports and lock them in place.

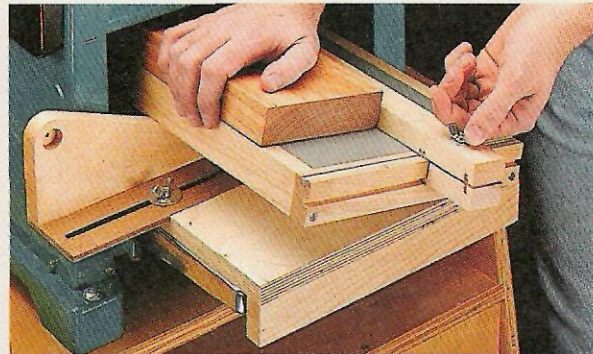

**2** After positioning the fence so the workpiece is flush with the edge of the table, it's just a matter of tightening the wing nuts to clamp it to the table.

# Using Lathe Scrapers

*“Scraped” doesn’t accurately describe the finish from this group of turning tools.*

**W**hy is it that scrapers have a bad reputation when it comes to turning on the lathe? The common answer is projects are “supposed to be cut, not scraped.” But a scraper that’s properly sharpened and used can generate fine shavings that result in a smooth finish, see photo at right.

I almost always use a scraper when I turn a face-plate project (like a bowl). In many cases, it’s the only way to shape some parts of the project. And for some projects (like the ring boxes on page 12), scrapers are the *only* tools you’ll need to use to shape the entire project.

**BURR.** So what is a scraper actually? Basically, it’s a turning tool that uses a *burr* to do the cutting. Unlike a gouge, which cuts as the bevel rides against the workpiece, a scraper is held against the

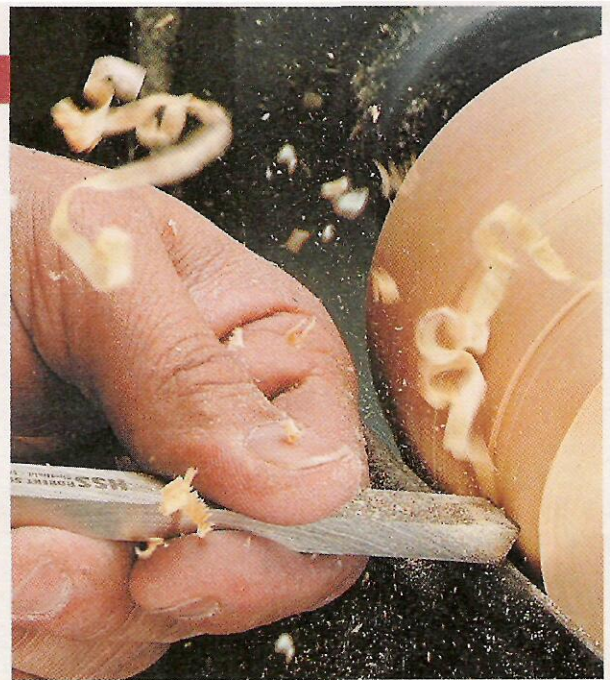

workpiece so only the burr cuts.

The nice thing about a scraper is that it’s a safe and predictable tool to use. Because the burr that does the cutting is rather short, it limits the “bite” or depth of cut you can make as the workpiece turns.

Besides being easy to use, scrapers come in a wide variety of profiles. This includes square-end, round-nosed, and several other profiles. For mail order sources of scrapers, see page 31.

**SHARPENING.** Regardless of the profile, a bench grinder is the key to creating the burr on the end of the scraper. The important thing is to use the correct type of wheel and the proper grit.

For my scrapers (and other turning tools), I use a white aluminum-oxide wheel. It grinds cooler than the grey silicon-carbide wheels normally supplied with most grinders. This way you’re less likely to overheat the scraper and draw the temper.

To remove a nick or to rough shape a scraper, I use an 80-grit wheel. Then, I follow up with a 120-grit finishing wheel. With the proper wheel in the grinder, creating the burr is a simple matter, see box at left.

**BURNISHING A SCRAPER.** Although you can use the scraper with the burr that’s formed by the grinder, I like a burr that’s been burnished, or rubbed, on the end. This creates a burr that’s smoother than the one you get from a grinder. And it’s also stronger — so you won’t have to sharpen the scraper as often.

For this type of burr, you still start with a bench grinder — but only to establish the bevel. Once that’s set, you need to *remove* the burr by honing the top of the scraper on a fine (1000-grit) sharpening stone. With the rough burr removed, you’re ready to burnish a smooth one on the end of the scraper.

The only problem is the hardness of a high-speed steel scraper makes it difficult to form a burr. To make this task a little easier, there’s a simple jig you can use, see the box on page 11.

## Sharpening a Scraper

Sharpening a scraper is easy. The first thing you’ll need to do is set the tool rest to match the bevel angle on the scraper, see detail below.

With the rest locked in place, creating the burr is just a matter of setting the scraper flat on the rest and sliding the cutting edge along the edge of the wheel, see photo. As you grind the scraper, a burr forms along the top edge, see inset photo.

For curved edges, the technique is a little different. To avoid grinding a flat spot, you’ll need to swing the handle to the side as you move the cutting edge across the edge of the wheel, see drawing.

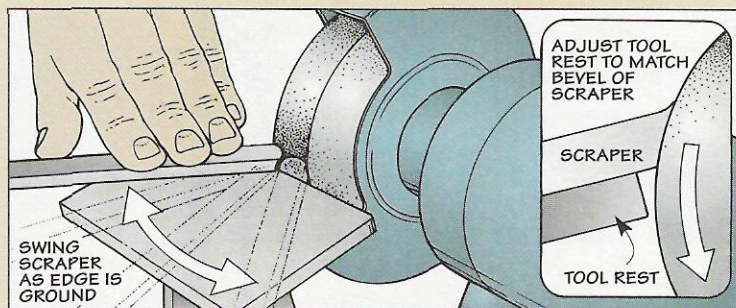
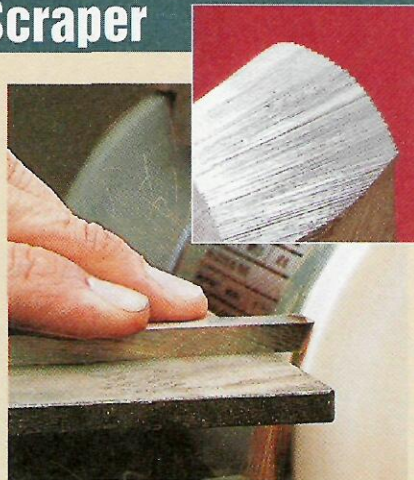

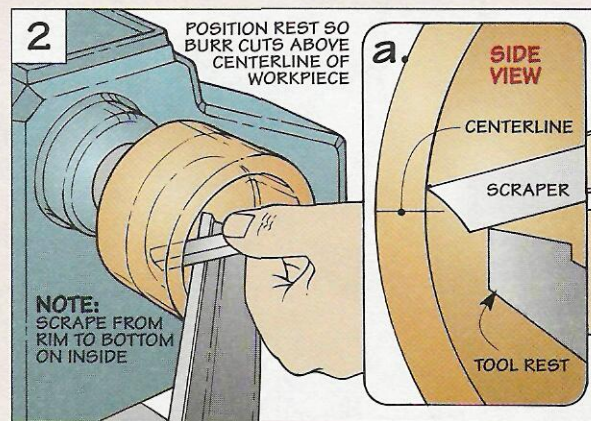
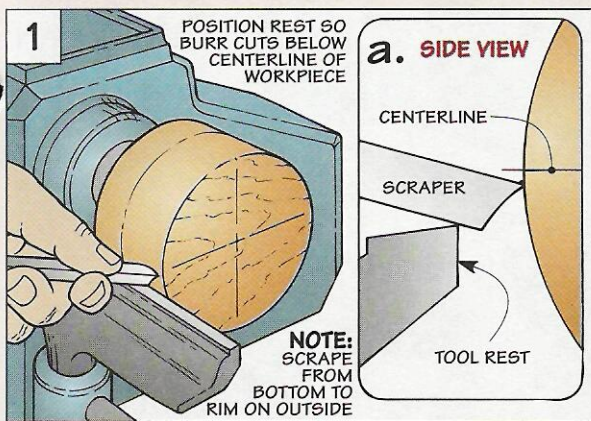

**USING A SCRAPER.** Whether the burr is formed by the grinder or it's burnished, the scraper is used the same way. The main thing to remember is all scrapers are used in a "downhill" manner.

The reason is the bevel of a scraper doesn't do the cutting — the burr does. That means the burr needs to be positioned correctly. To do this, the scraper needs to be held flat on the rest with the handle *raised* slightly. This allows the burr to cut.

Besides holding the scraper downhill, you'll also need to pay attention to where the burr actually contacts the workpiece. The reason for this is that even though the burr limits the depth of cut, it's still possible for it to "catch" on the workpiece.

**POSITION TOOL REST.** To keep the scraper from "digging in," you'll want to position the tool rest so there's no material below the cutting edge of the scraper. This depends on whether you're scraping the inside or outside of the workpiece.

When you're scraping on the outside of a workpiece (a bowl for example), the burr should be at or

slightly *below* the centerline, see Figs. 1 and 1a. And on the inside of the bowl, you'll need to be slightly *above* the centerline, see Figs. 2 and 2a.

**DIRECTION.** With the height set, you're ready to start cutting. The main thing is to follow the grain of the wood as much as possible.

What this means is that on the outside of the bowl, you'll cut from a smaller diameter like the bottom of the bowl, to a larger diameter like the rim. And on the inside, it's just the opposite. The cut proceeds from the rim down to the bottom.

Regardless of the direction, you'll want to use a light touch with a scraper. It's easy to tear out the wood fibers where the grain changes direction. And fixing this is difficult without extensive sanding.

**FINISH CUTS.** One thing you'll notice is that the burr will wear away as you're turning. So once you're making more dust than shavings, it's best to grind a new burr. Then you can make your final cuts with a sharp scraper. This way, you'll end up with a smoother finish that requires less sanding. 

## Burnishing Jig

A burr straight from the grinder is usually a little "rough around the edges." One way to make a smoother burr (and one that lasts longer) is to *burnish* the end of the scraper. But the hardness of a high-speed steel scraper makes that quite difficult.

To make it easy to apply the pressure necessary to burnish the edge, the Veritas company has a simple burnishing jig available, see photo. The jig consists of two removable pins and an aluminum base that can be screwed to a benchtop or simply clamped in a vise.

The pins fit into holes in the base and can be positioned to accommodate a wide variety of scrapers. A tapered carbide pin rolls the burr as the scraper pivots against the straight pin. The pivot pin gives you the leverage necessary to roll a burr on a high-speed steel scraper, see inset photo. For sources, see page 31.

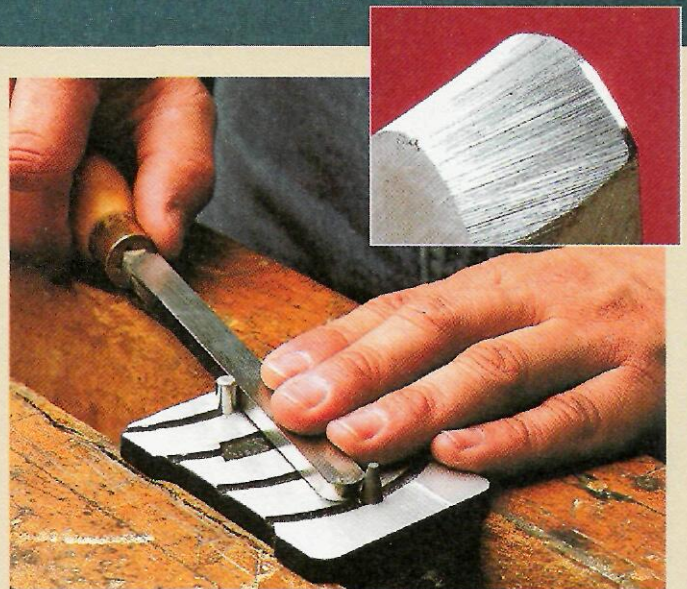

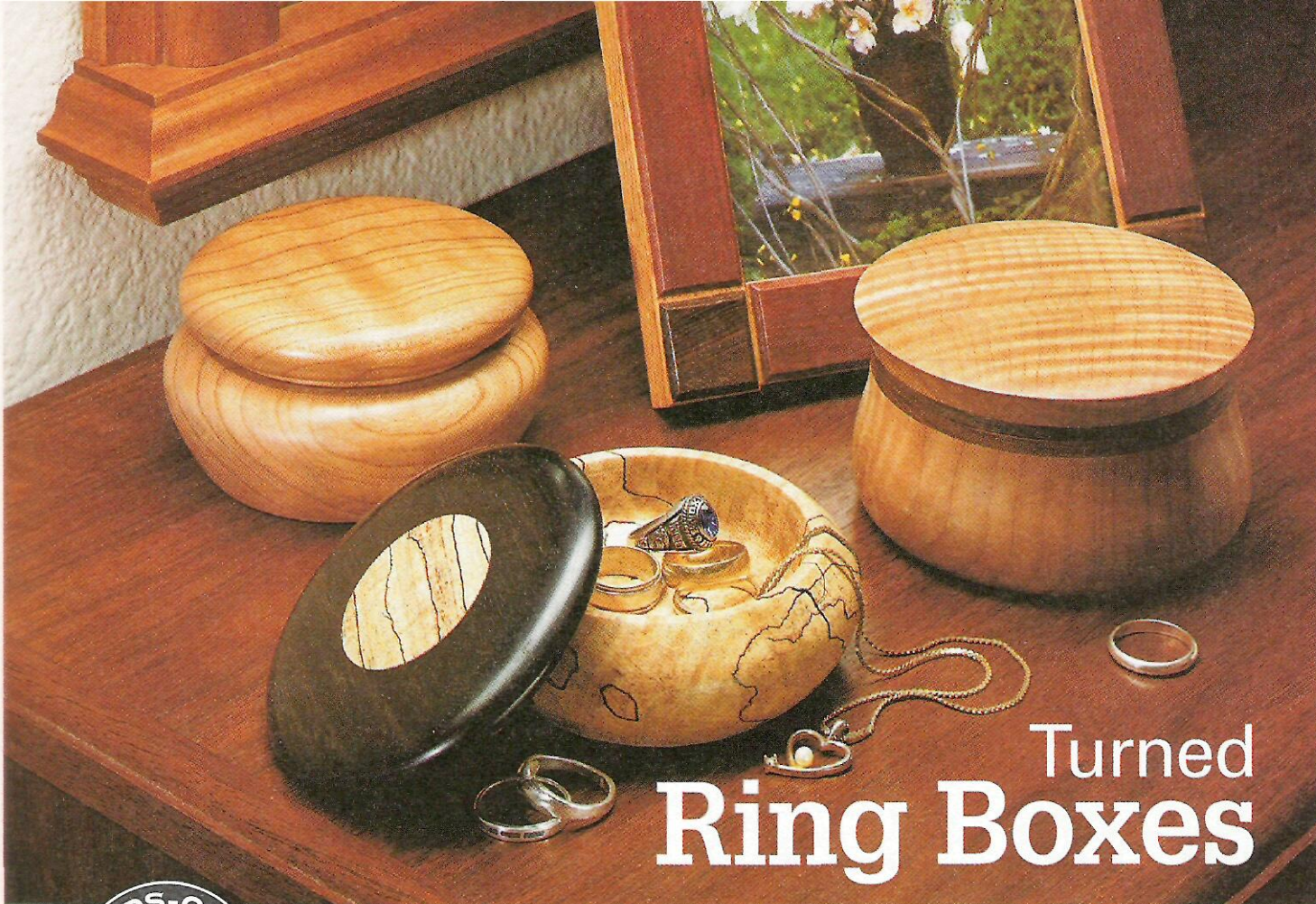

# Turned Ring Boxes



**T**hey say good things come in small packages. And in the case of these ring boxes, I couldn't agree more. But the most intriguing thing about these packages isn't what's on the *inside*. It's the "wrapping" on the *outside*.

To set each one apart, we turned three different styles of ring boxes — each with a different type of wood, see photo above and margin on next page.

While these boxes present a few of the possibilities, they really only scratch the surface. You may want to change the shape entirely. Or experiment with a piece of highly figured wood you've been saving for that special project.

**TWO BLANKS.** Regardless of the type of wood, each ring box starts out as two blanks — one for the lid and another for the base of the box. Note: It's best to start with oversize blanks.

Although you could screw each blank directly to a faceplate, that presents a problem. Once the lid (or base) is completed, the screw holes may show. So I glued each blank to a scrap block first, see drawing below left. Then this scrap block is screwed to the metal faceplate of the lathe.

**TRUE UP THE BLANK.** After mounting each blank, you'll need to "true" it up before turning it to shape. First, the outside of the blank is turned to a

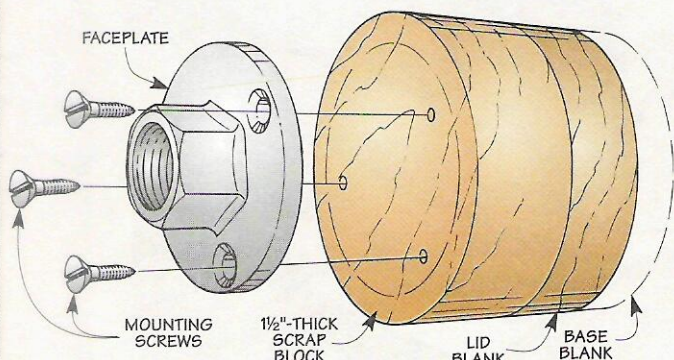

**NOTE:** LID BLANK SHOWN. BASE BLANK WILL BE THICKER. ALL PIECES ARE 4 1/2"-DIA. (RGH.)

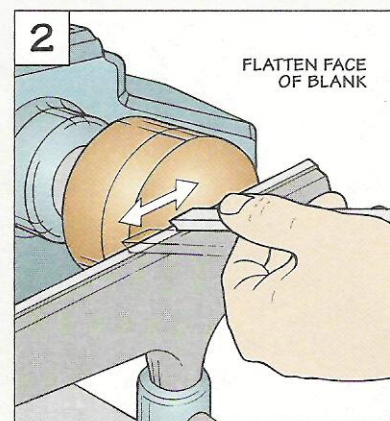
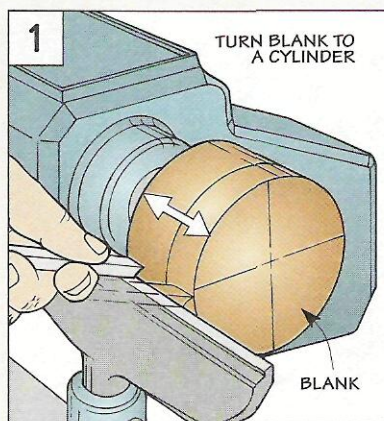

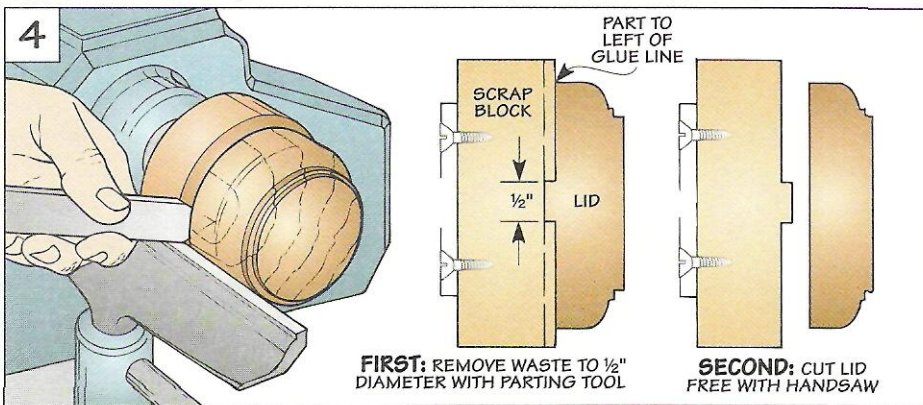
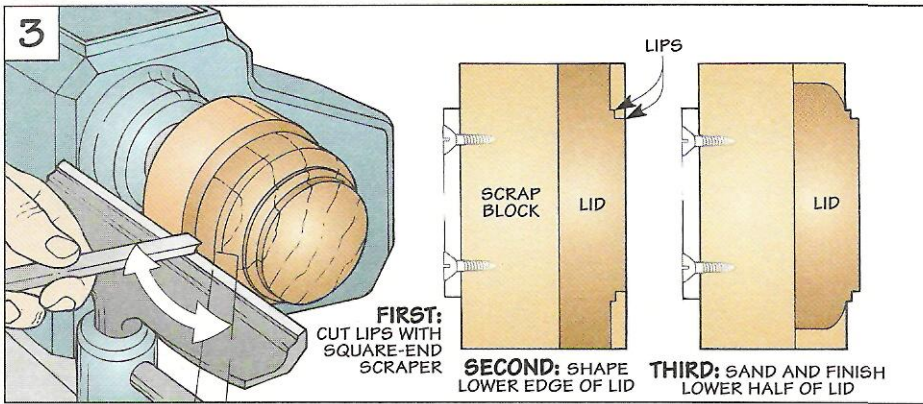

cylinder of the desired diameter of the lid (or base), see Fig. 1. (I used a square-end scraper.) (For more information on using a scraper, refer to the technique article on page 10.) And second, the face of the blank is scraped flat, see Fig. 2.

**THE LID**

Once the blank has been trued up, you're ready to turn the lid for the ring box. I concentrated on the bottom part of the lid first. The top part is turned later — after the base of the box has been completed.

**LIP** The first step is to create a small lip that will fit down inside the base of the box, see Fig. 3. It keeps the lid from sliding off the base.

To create this lip, I used a square-end scraper and simply "pushed" it into the face of the blank.

On two of the boxes I added a second lip, see margin. This forms a small "stair step" on the bottom of the lid. When the lid is placed on the base, this step creates a narrow shadow line where the lid and base come together.

After cutting the lips, the next step is to shape the bottom edge of each lid. I used a square-end scraper to gently curve the outside corner on the lower part of the lid, see Fig. 3 and margin.

(Note: Because the sides of the lid and base on the curly maple and walnut ring box form a continuous curve from top to bottom, it only has a single lip. And all the shaping on the outside of both parts is done after the lid is attached to the base.)

**FINISH.** There's one last thing to do before removing the lid from the scrap block. That's to sand and finish the part of the lid that's already turned. (For tips on applying a finish to a project on the lathe, refer to page 28.)

**REMOVE LID.** After applying the finish, you're ready to remove the lid from the scrap block, see Fig. 4. A simple way to do this is to use a parting tool.

What works well here is to cut just to the left of the glue line between the scrap block and the lid, see Fig. 4. But instead of going all the way through, I leave about a 1/2" of waste. This way, I can turn off the lathe and use a hand saw to cut the lid free.

**SPALTED MAPLE & EBONY**

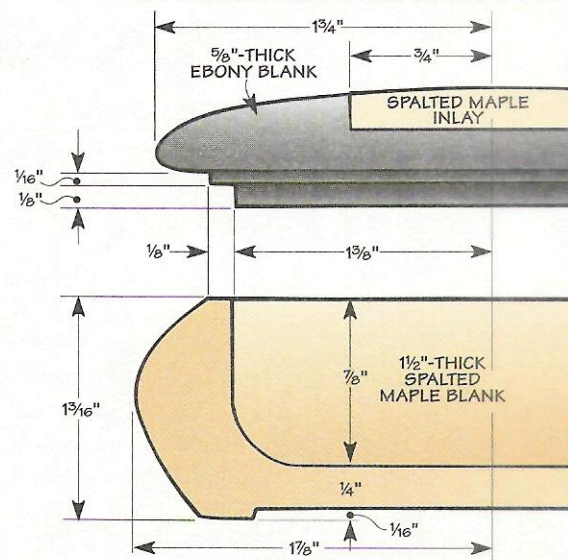

**CURLY MAPLE & WALNUT**

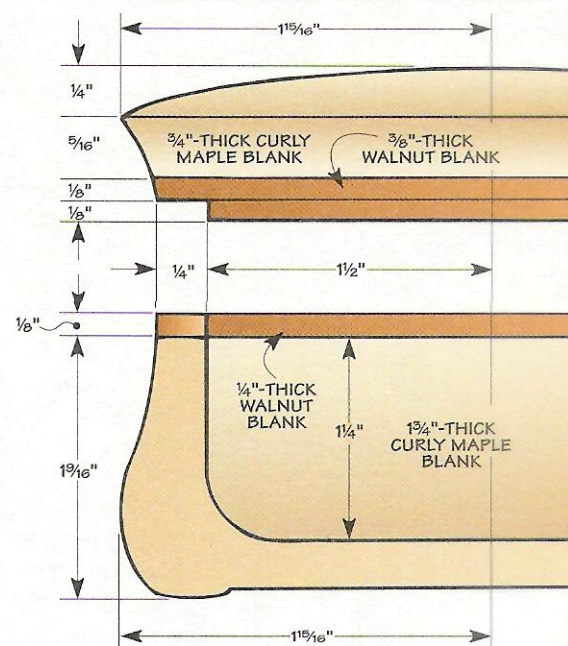

**CHERRY**

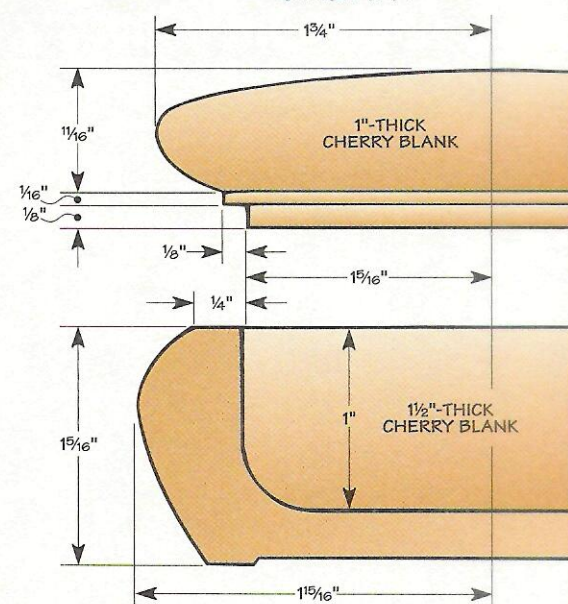

## Base

Before completing the lid, you'll need to turn your attention to the base of the ring box. Once the inside of the base is hollowed out, the lid will fit in the opening like a cork in a bottle. This will make it easy to turn the outside of the lid to final shape.

**BLANK.** The base starts out as a blank that's glued to a scrap block. The only difference is the blank is thicker. This way, you'll be able to make the opening deep enough so that the rings and jewelry inside won't keep the lid from closing.

Just like with the lid, the first step after mounting the blank to the lathe is to true it up. Then you can start shaping the outside. But I don't go for the final shape here — that happens later once the lid is attached to the base.

**ROUGH SHAPE.** After truing up the blank, the next step is to concentrate on establishing the rough shape of the base.

Here again, all it takes is a square-end scraper to define the outside shape of the bowl, see Fig. 5. One thing to be aware of is that you'll be cutting into the scrap block as you shape the base. But that's okay. In fact, you may need

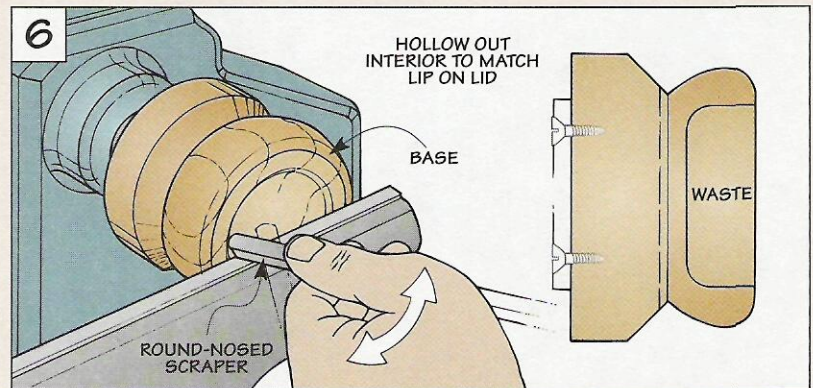
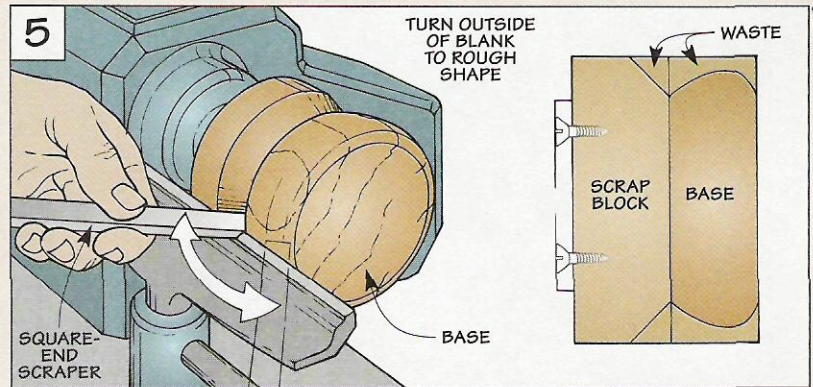

to "shave" away some of the scrap block to provide clearance for the scraper. After rough shaping the outside, I switch to a round-nosed scraper to hollow out the inside.

**HOLLOW BASE.** Removing the material to hollow out the base is a

little like using a shovel to dig a hole. You start by removing material near the center. Then continue to the edge, scooping the material out as the opening gets wider and deeper, see Fig. 6.

As you approach the rim, you'll want to make your cuts a little

## Adding An Inlay

Adding an inlay is a three-step process. The key is to make the inlay *before* you start on the lid.

To make the inlay, use a scraper to turn a thin disk ( $\frac{1}{4}$ " ) from a piece of wood glued to a scrap block, see Fig. 1.

When you're ready to add the inlay to the lid, scrape a shallow ( $\frac{3}{16}$ " ) pocket to match the size of the disk, see Fig. 2.

Finally, glue the inlay in place, see Fig. 3. Then, as you're completing the final shaping of the lid, simply shave the inlay flush.

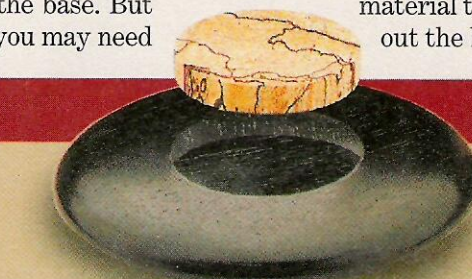

◀ **Inlay.** This spalted maple inlay adds a decorative accent to the dark ebony lid of this ring box.

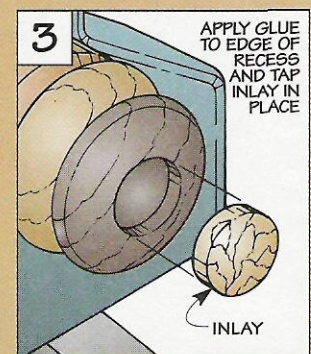
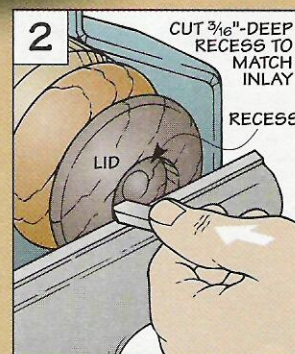
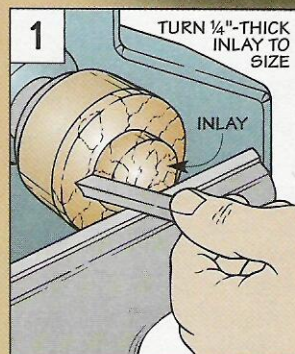

finer. This way, you can check the fit of the lid as you go.

What you're looking for is a nice, tight fit between the base and the lid. This allows you to use the base to grip the lid while you turn both to final shape.

But don't worry if you pare away a little too much of the side and the fit is a little loose or it slips a bit. It's easy to make it fit tight again. A simple way to do this is to temporarily add a paper towel between the lid and the base, see top margin photo.

**FINAL SHAPING.** With the lid securely attached to the box, you can start to refine the overall shape as well as form the top of the lid, see Fig. 7.

**INLAY.** If you're going to add a contrasting piece of wood as an inlay to the top of the lid, this is the time to form the recess in the lid. The inlay is glued into a pocket that's scraped into the lid, see box on page 14. Once the glue dries, the inlay is shaved flush with the top of the lid.

**FINISH.** Before you go any further, now's the time to sand and finish the outside of the base and lid. Once that's complete, you can remove the lid and set it aside.

Note: If the lid is a little stubborn and you have trouble removing it, you can use a dowel to tap it free, see margin.

**ENLARGE OPENING.** To turn the outside of the lid and base, the lid had to fit tight. But you don't want that kind of fit once the ring

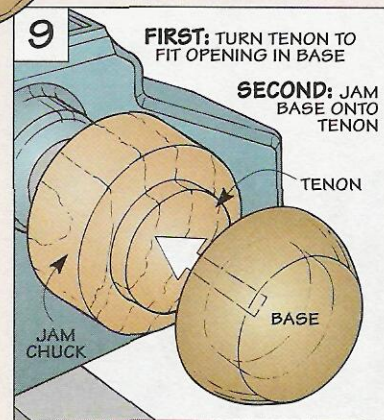
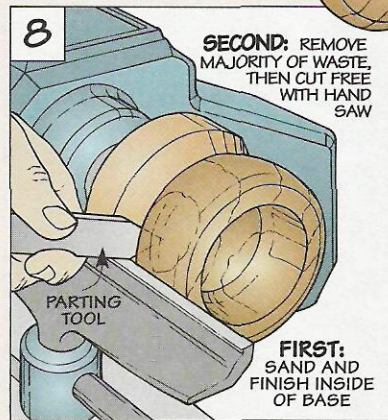
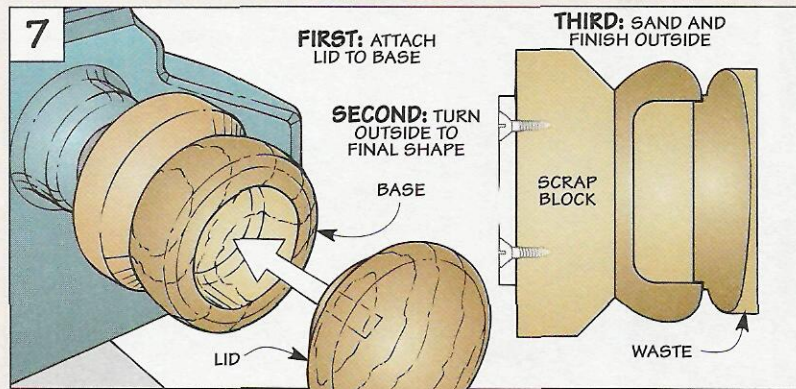

A paper towel slipped between the lid and box will help tighten up a loose-fitting lid so you can turn both to final shape.

box is complete. Otherwise, if you were to pick up the lid, the base would likely go with it.

At this point what you're looking for is a loose fit. For that you'll need to take a little more material off the side of the base.

You probably don't even need a scraper to do this. Sanding the inside of the box should remove enough material so the lid will fit loosely in the base.

Once the lid fits the way you want it to, you can apply a finish to the inside of the base.

**REMOVE BASE.** Now that the sanding and finishing are complete, you can remove the base from the scrap block. Here again, a parting tool takes care of removing most of the waste, see Fig. 8. Then, turn off the lathe and cut the base free with a hand saw.

**TURN BOTTOM.** All that's left now is to shape and finish the bottom of the base. The trick is to attach the base to the lathe without leaving any marks as to how it was mounted.

A simple way to hold small objects like the base is with a jam chuck, see Fig. 9. (Refer to article on page 29.)

Once the base is mounted, completing the bottom is just a matter of forming a shallow recess, see Fig. 10. This way, if the wood should change shape a little, it will still sit squarely on a flat surface.

**FINISH.** Finally, after you turn the recess to create the foot, you can sand the bottom of the base and then apply a finish.



To remove a tight fitting lid, gently tap a dowel along the joint line between the lid and box.

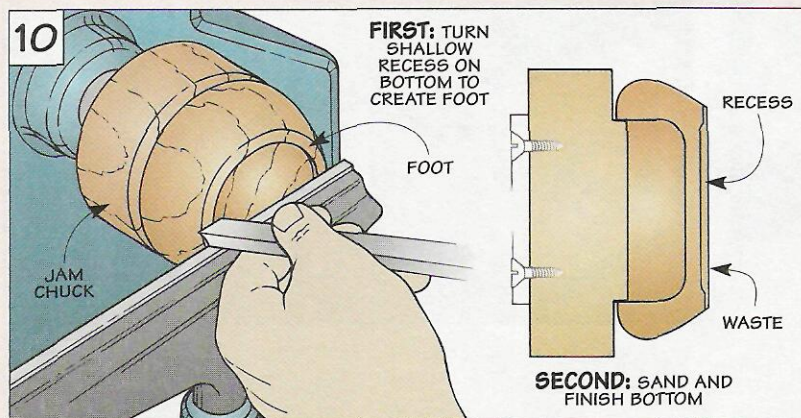

# Drill Press Stand

*This roll-around tool stand provides a solid platform for your benchtop drill press and plenty of storage for bits and accessories.*

**M**ost roll-around tool stands are like four-year old kids — they won't sit still. Even when you lock the casters, they still have a tendency to "creep" around the shop.

But this roll-around stand for your benchtop drill press won't budge an inch when you're using it. That's because it has a set of unique casters on the bottom that lock both the wheel *and* the shaft. (For more on this, refer to page 19.)

Getting the stand to stay put was one thing. But we were also concerned it might be topheavy and have a tendency to tip when rolling it around. (Especially since our drill press weighs in at 150 lbs. — and most of that weight is in the motor which is quite high up.)

**SANDBOX.** The solution was to offset the weight of the drill press by filling the lower part of the stand with ballast — a "sandbox" filled with about 100 lbs. of sand, see photo A below.

**OPEN BASE.** To support the combined weight of the sand and the drill press, the stand needed to be rigid and strong. So it's designed with a sturdy, open base that's made of "two-by" Douglas fir and  $\frac{3}{4}$ "-thick Baltic birch plywood.

**STORAGE.** The base also provides plenty of storage. Pull-out trays organize drill bits and small accessories, see photo B. And an open shelf on the bottom provides easy access to large items, see photo at left.

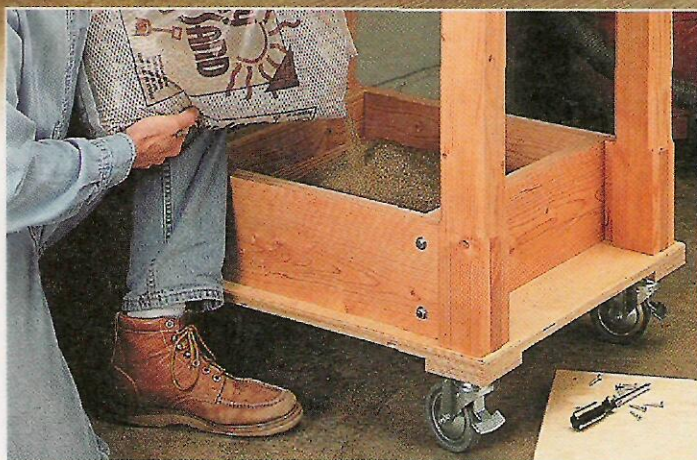

**A. Sandbox.** To add stability, a "sandbox" in the bottom of the stand holds about 100 lbs. of sand. This extra ballast prevents the stand from tipping when you roll it around.



**B. Pull-Out Trays.** Three pull-out trays provide storage for drill bits and accessories. Scooped sides make it easy to remove bits. And custom bit holders keep them organized.

Hardware

**EXPLODED VIEW**  
OVERALL DIMENSIONS:  
24"W x 34"H x 30"D

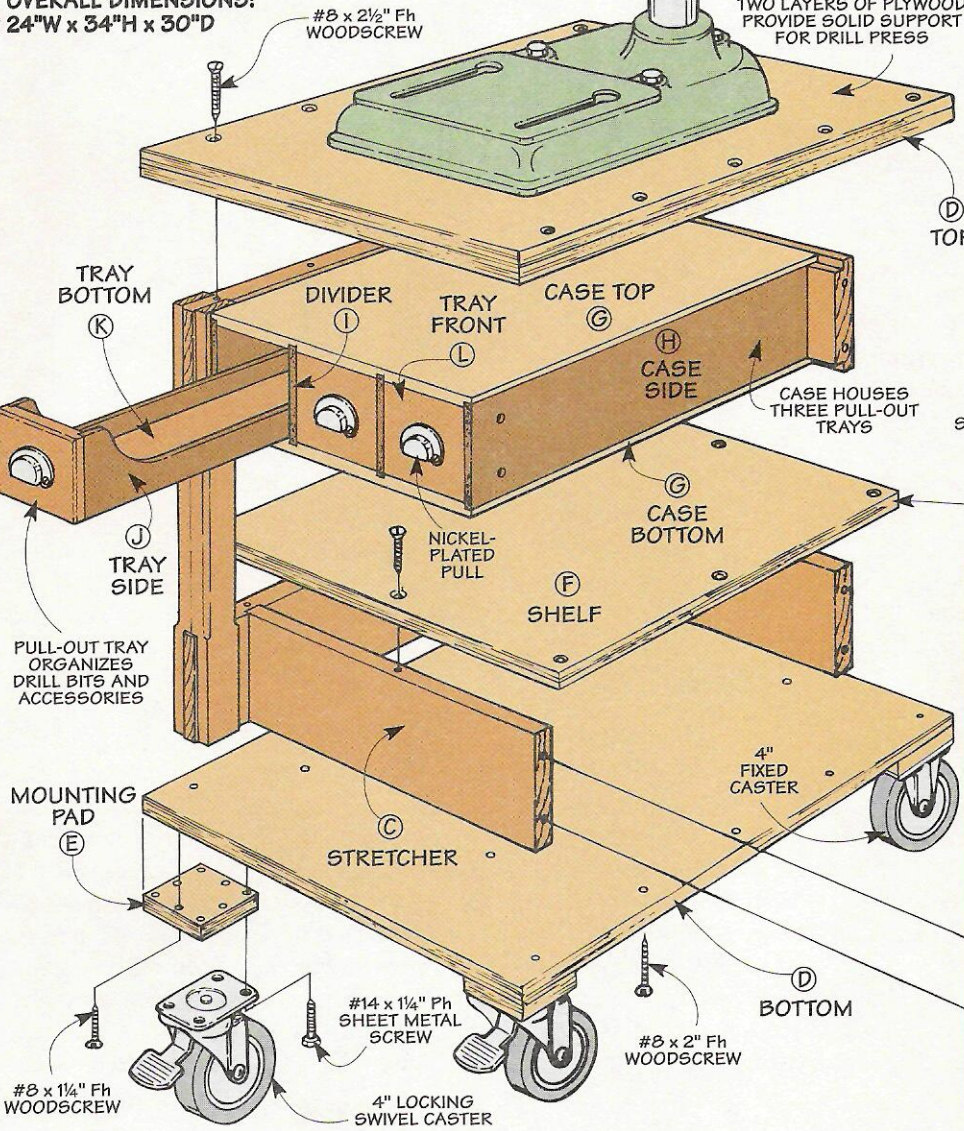

- (3) Pulls w/Screws (Nickel-Plated)
- (16) #14 x 1/4" Ph Sheet Metal Screws
- (20) #8 x 1/4" Fh Woodscrews
- (25) #8 x 2" Fh Woodscrews
- (12) #8 x 2 1/2" Fh Woodscrews
- (12) 5/16" x 4 1/2" Lag Screws
- (12) 5/16" Flat Washers
- (2) 4" Fixed Casters
- (2) 4" Locking Swivel Casters
- (1) Package of 100 Wire Brads (1"-long)

Note: To order a hardware kit for the Drill Press Stand as well as the Table & Fence shown on page 22, refer to page 31.

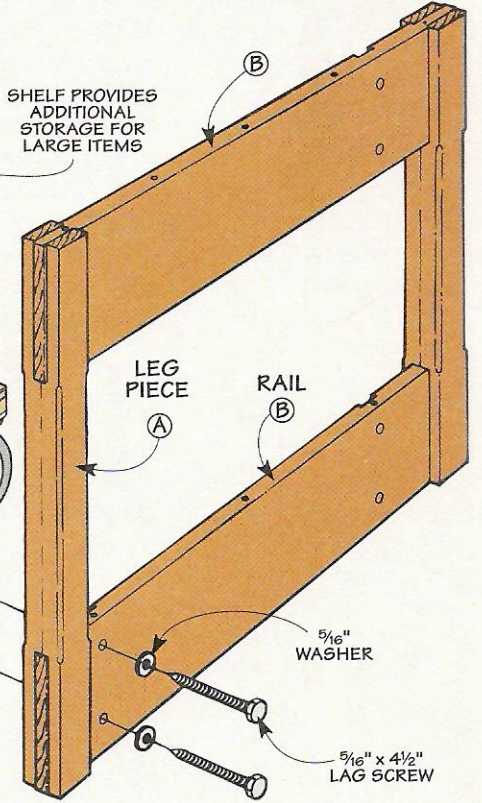

Cutting Diagram

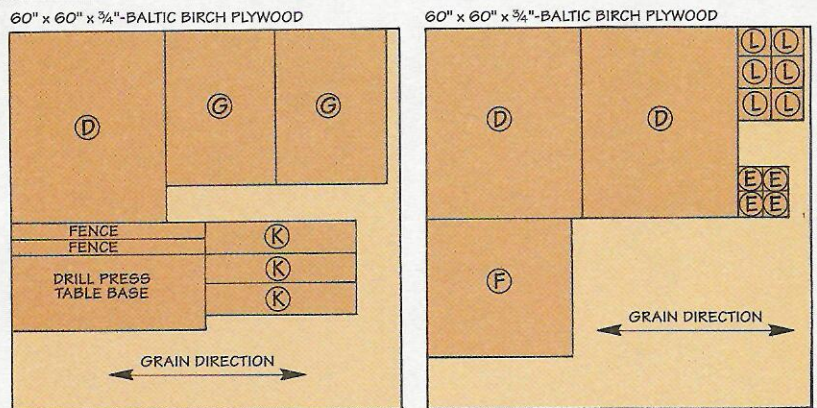

Also Needed:  
(3) 2 x 8 - 96 (Douglas Fir)  
(1) 2 x 8 - 48 (Douglas Fir)  
(1) 48" x 48" Sheet of 1/4" Hardboard

NOTE:  
PARTS OF DRILL PRESS TABLE AND FENCE ARE SHOWN ON PAGE 22

Materials

- Base**
- A Leg Pieces (8) 1/2 x 3 - 26
  - B Rails (4) 1/2 x 6 1/2 - 29 1/4
  - C Stretchers (3) 1/2 x 6 1/2 - 19
  - D Top/Bottom (3) 30 x 24 - 3/4 Plywood
  - E Mounting Pads (4) 4 x 4 - 3/4 Plywood
  - F Shelf (1) 22 x 22 1/2 - 3/4 Plywood
- Case**
- G Top/Bottom (2) 24 1/4 x 17 - 3/4 Plywood
  - H Sides (2) 5 3/4 x 23 1/2 - 1/4 Hardbd.
  - I Dividers (2) 5 3/4 x 23 1/2 - 1/4 Hardbd.
- Trays**
- J Sides (6) 4 15/16 x 23 1/8 - 1/4 Hardbd.
  - K Bottoms (3) 4 3/4 x 23 1/8 - 3/4 Plywood
  - L Fronts/Backs (6) 4 15/16 x 5 1/4 - 3/4 Plywood

Note: We used 3/4"-thick Baltic birch for all plywood parts because it's flat, stable, and free of voids.

# Base

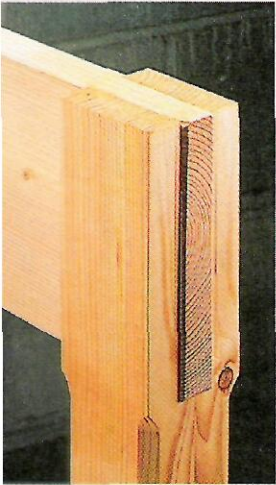

▲ A strong mortise and through tenon joint provides the cornerstone for a sturdy base.

I began work by making a sturdy base to support the drill press. It consists of a "two-by" frame and a top, bottom, and shelf made from 3/4" plywood.

**FRAME.** The frame starts out as two end assemblies, see drawing at right. Each of these assemblies is made up of two thick legs and a pair of wide rails that are held together with mortise and through tenon joints, see margin.

But you don't have to worry about *drilling* these mortises. That's because they're formed by gluing up two *leg pieces* (A) with a rabbet in each end, see Fig. 1. To keep these pieces aligned during glue-up, I used a simple jig, see page 30.

When the glue dries, the legs are almost complete. But to ease the sharp edges, I routed a stopped chamfer on all four corners.

**RAILS.** The next step is to add the *rails* (B), see Fig. 1. A tenon on the end of each rail extends all the way through the leg and sticks out 1/8" in front.

Why use a *through* tenon? Because it's easier to cut the tenons a bit "long" than to get

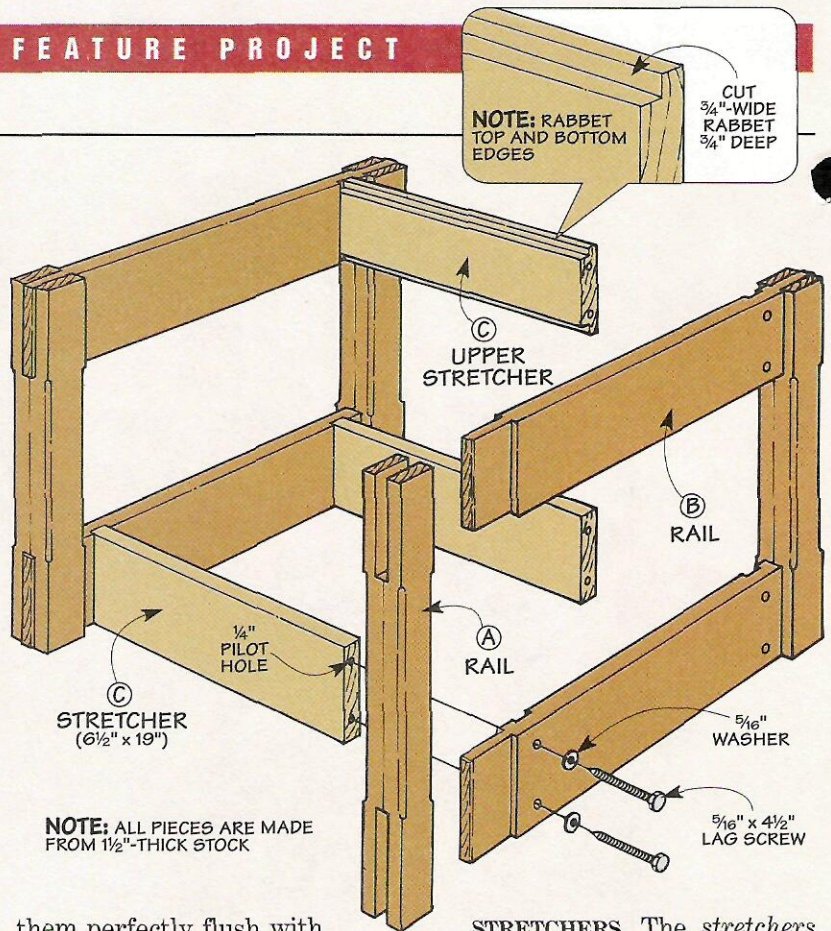

them perfectly flush with the front of the leg.

Before gluing up the end assemblies, there are two things to do. First, the ends of the tenons (except for the part that will rest against the top or bottom) are chamfered. Second, you'll need to cut dados in the rails for the stretchers that are added next.

**STRETCHERS.** The *stretchers* (C), connect the two end assemblies. To create an opening for a case that holds the trays, a *single* stretcher runs across the top. And *two* stretchers span the bottom. Together with the rails and a plywood bottom they form a box for the sand.

Although the stretchers are

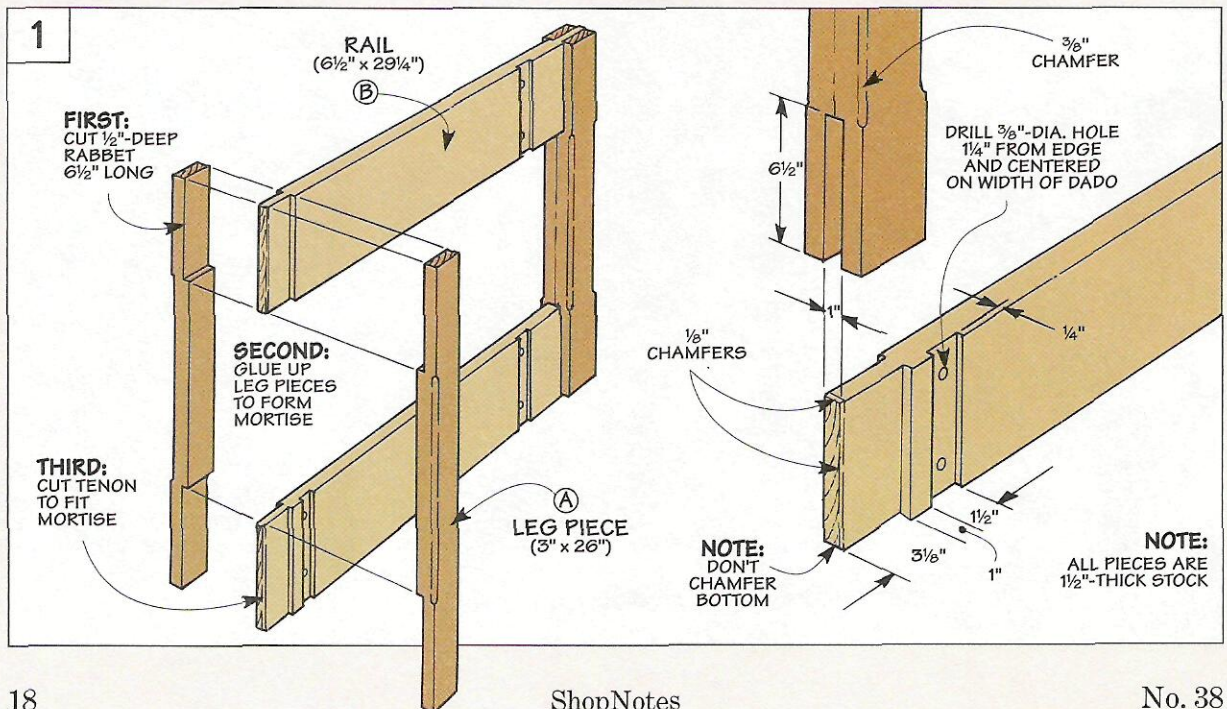

the same size, there is one difference. The upper stretcher is *rabbeted* along the top and bottom inside edges, see drawing on page 18. These rabbets provide a surface that will allow you to secure the case that holds the trays.

**ASSEMBLY.** Now it's just a matter of fitting the stretchers between the end assemblies and screwing them in place. (I used lag screws.)

**TOP & BOTTOM.** With the basic frame complete, I added a plywood *top* and *bottom* (D), see drawing at right. These pieces are the same size. But since my drill press is quite heavy, I "beefed up" the top by gluing up two layers of plywood.

Next, to ease the edges of the top and bottom, I routed chamfers as shown in details 'a' and 'b.' Then just center the top on the base and screw it in place.

The bottom is also attached with screws, see Fig. 2. But first, you'll have to turn the base upside down. This is also a good time to attach the *mounting pads* (E) for the casters with glue and screws.

**CASTERS.** To make the base easy to roll around, I mounted locking swivel casters along the front edge and fixed casters in back, see drawing above and box below.

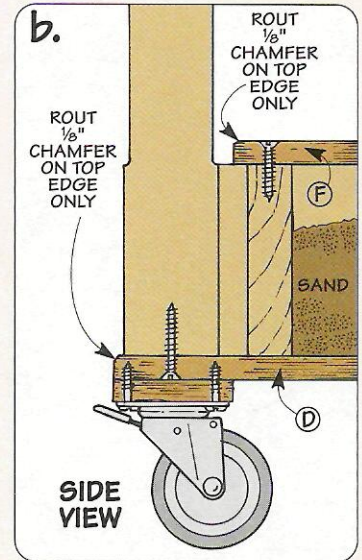
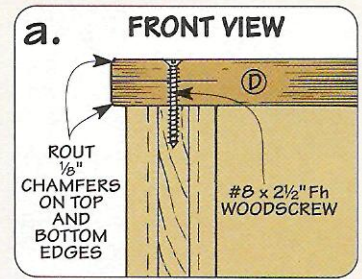
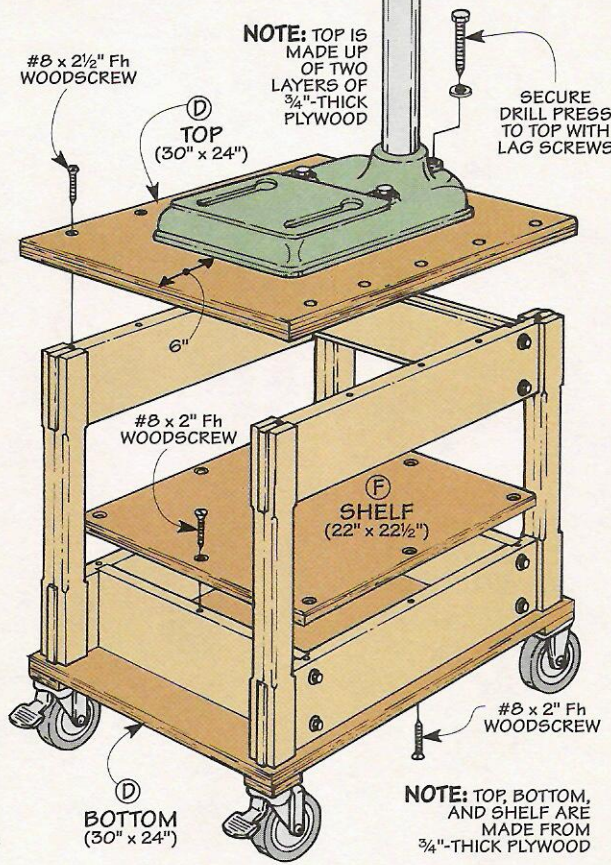

**FILL SANDBOX.** After setting the base on its casters, I filled the "sandbox" with sand. This provides extra ballast that helps offset the weight of the drill press and keeps the base from tipping. To provide storage underneath (and enclose the sandbox), I added a plywood *shelf* (F).

**MOUNT DRILL PRESS.** After screwing the shelf in place, all that's left is to mount the drill press to the top of the base. (I used lag screws.) Note: I positioned the base of the drill press 6" in from the front edge. This provides room to set one of the trays on top of the stand while I'm working.

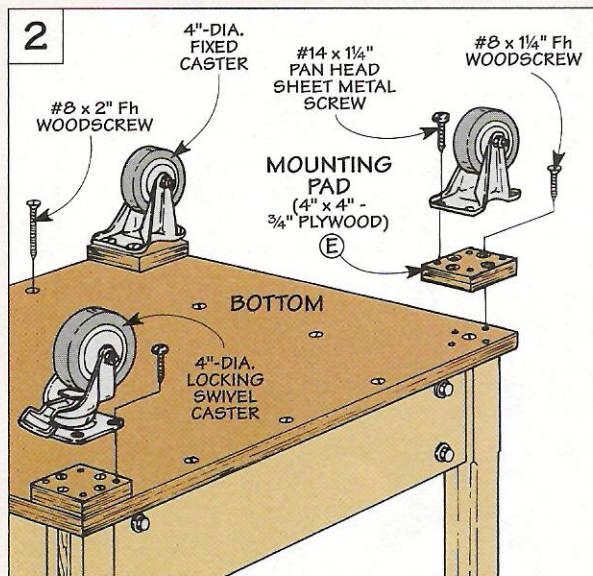

## Locking Casters

These locking swivel casters may look like ordinary casters. But there's one big difference.

When you step on the brake of the swivel caster, it stops the wheel from rolling. But it also locks the base of the caster so it won't swivel.

This makes it ideal for roll-around tool bases that creep around the floor — even when they're "locked."

Another nice thing is the steel wheels spin on ball bear-

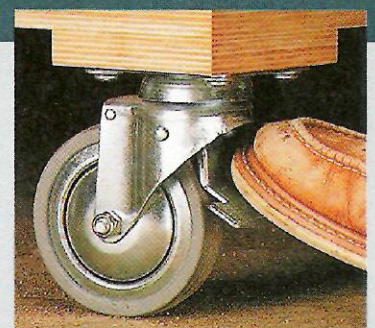

ings. And the tires are solid rubber. As a result, they roll smoothly across uneven floors.

For sources of both fixed and swivel casters, refer to page 31.

# Trays

The base does more than provide a sturdy mounting platform for the drill press. It also houses a case with three pull-out trays that keep your drill bits and accessories organized, see Fig. 3.

## CASE

The case is just an open-ended box with a separate compartment for each tray. It's designed to fit into the opening between the two end assemblies of the base.

**TOP & BOTTOM.** I began by making a plywood *top* and *bottom* (G) for the case, see Fig. 4. One thing to note here is the top and bottom aren't designed to sit flush with the back end of the case. Instead, they extend  $\frac{3}{4}$ " past the back of the case. Besides helping to support the case, these lips provide a way to attach it to the base.

After cutting the top and bottom to size, the next step is to

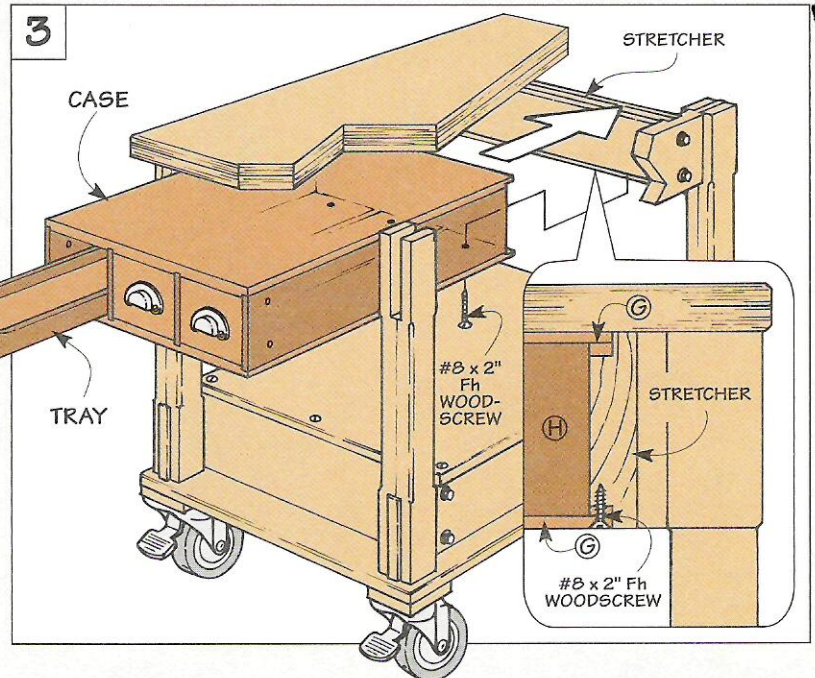

in Fig. 3. Besides helping to support the case, these lips provide a way to attach it to the base.

After cutting the top and bottom to size, the next step is to

rabbet the two long edges of each piece. These rabbets will accept the sides of the case.

In addition to the rabbets, you'll also need to cut two dadoes in each piece for a pair of dividers that separate the case into compartments. Note: When determining the location of these dadoes, the goal is to end up with three compartments that are spaced evenly apart.

**SIDES.** Now you're ready to add the *sides* (H) of the case, see Fig. 4. These are pieces of  $\frac{1}{4}$ " hardboard that hold the top and bottom together. Remember, they're cut to length so they'll sit back  $\frac{3}{4}$ " from the back edge of the top and bottom.

To make it easy to attach the case later, it's best to drill two holes near the front end of each side now. Then just glue and tack the sides in place with short brads.

**INSTALL CASE.** At this point, you can install the case. What you want to do here is slide it all the way into the base until the top and bottom fit into the rabbets in the upper stretcher. With the top resting on the ledge formed by the rabbet, screw the

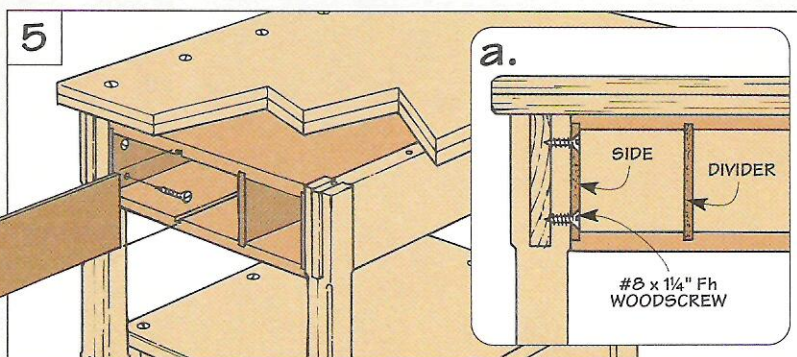
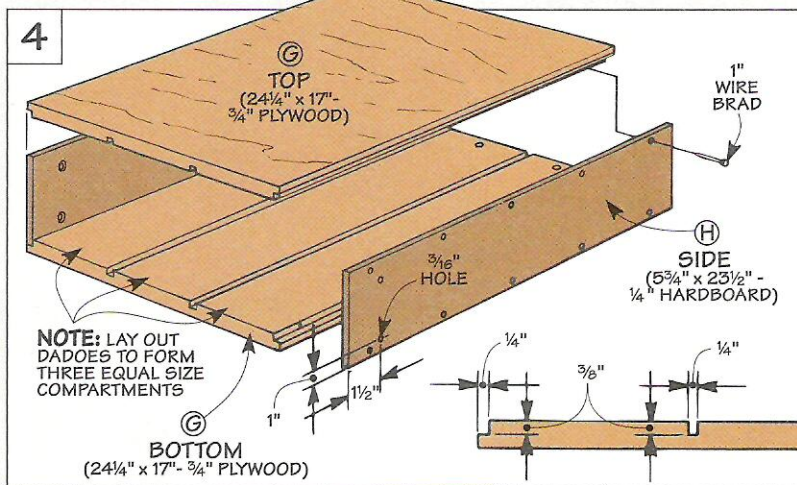

sides to the front legs, see Fig. 5a. Then secure the bottom with screws, see detail in Fig. 3.

**DIVIDERS.** Now all that's left is to add a pair of hardboard *dividers* (I) to form the compartments, see Fig. 5. After applying a few drops of glue to the dadoes in the bottom (G), simply slide the dividers into the case.

**TRAYS**

Once the case is completed, you can turn your attention to the trays. Basically, these are long, narrow boxes that fit into the openings in the case like a row of post office boxes.

To see why these trays provide such easy access to drill bits and other accessories, all you have to do is pull one out and set it on top of the drill press stand, refer to photo on page 16.

**SIDES.** For example, the hardboard *sides* (J) of the tray are "scooped" out, see Fig. 6. This provides clearance as you reach in and take out a drill bit.

**TRAY BOTTOM.** And the *bottom* (K) of the tray is a full 3/4" thick. (I used plywood.) This way, you can drill stopped holes in it to

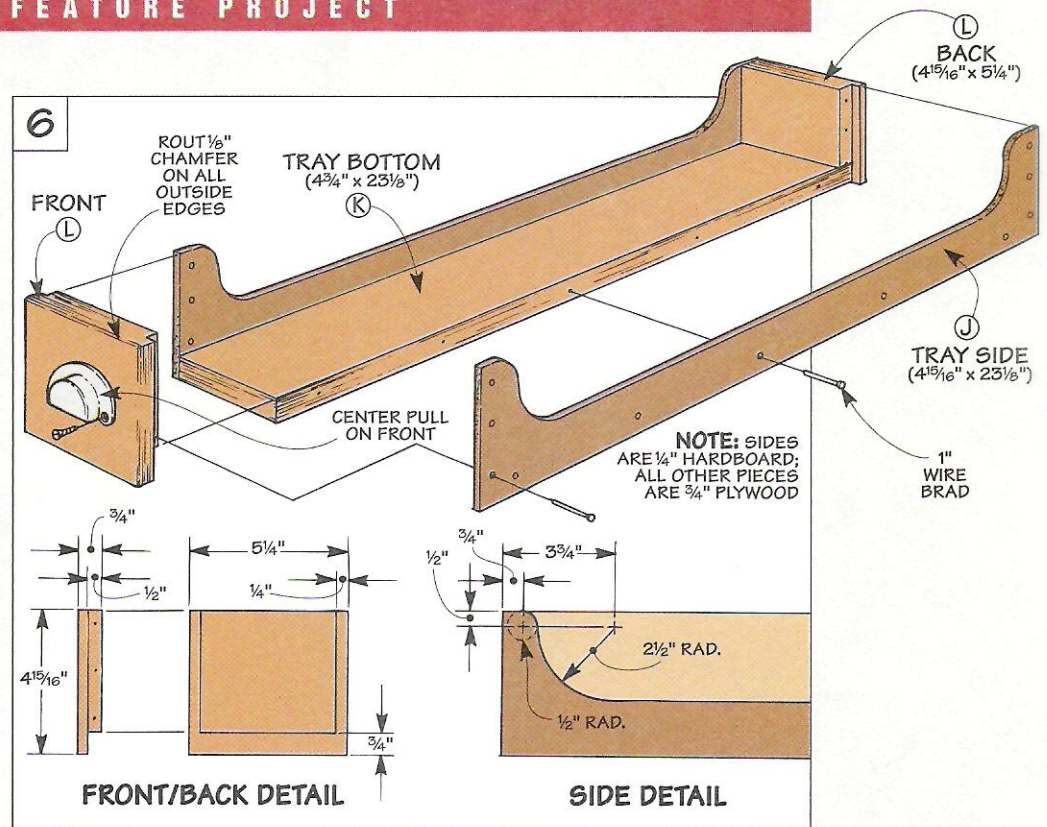

hold plug cutters, sanding drums, or your circle cutting bit. (For more information on custom drill bit holders, see the box below.)

**FRONT/BACK.** To enclose the ends of each tray, I added a *front* and *back* (L) piece made from 3/4" plywood, see Fig. 6. A pair of narrow rabbets accept the sides

of the tray. And the bottom of the tray fits in a wide rabbet.

**ASSEMBLY.** After routing an 1/8" chamfer around the outside edges of the front and back, the trays are simply glued and tacked together. Attaching a nickel-plated pull to the front of each tray provides the finishing touch.

**Custom Bit Holders**

To take full advantage of the space inside the trays, I customized each one to fit my drill bits and accessories.

**SHORT BITS.** This is easy for short bits and sanding drums. Just drill holes in the bottom of the tray and

stand the bits upright, see drawing.

**LONG BITS.** But the tip of a long bit would bump into the top of the case. So I made a block that tilts up when you want to remove a bit or lies flat for storage, see photo.

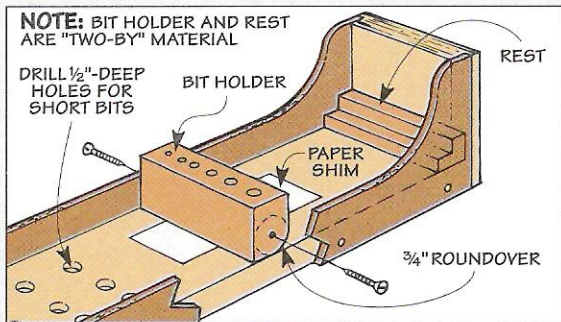

To prevent the holder from rubbing against the bottom of the tray, you'll need to round over one of the bottom corners. Leaving the opposite corner square forms a "stop" that keeps the holder upright.

Once the holder is completed, it's screwed to the

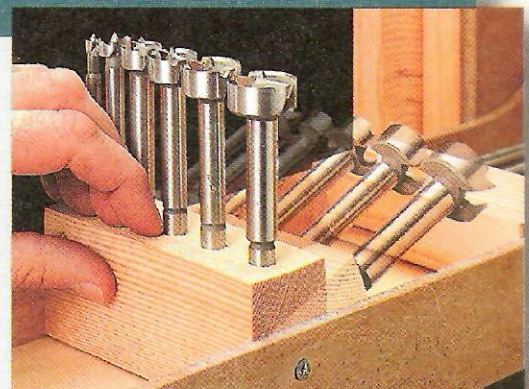

sides of the tray. A temporary paper shim provides just enough clearance to allow the holder to pivot smoothly.

**REST.** One last note. To support the tips of my spade bits, I glued a notched *rest* into the tray, see drawing.

# Drill Press Table & Fence

*Sometimes simple is best. This drill press table and fence is a perfect example.*

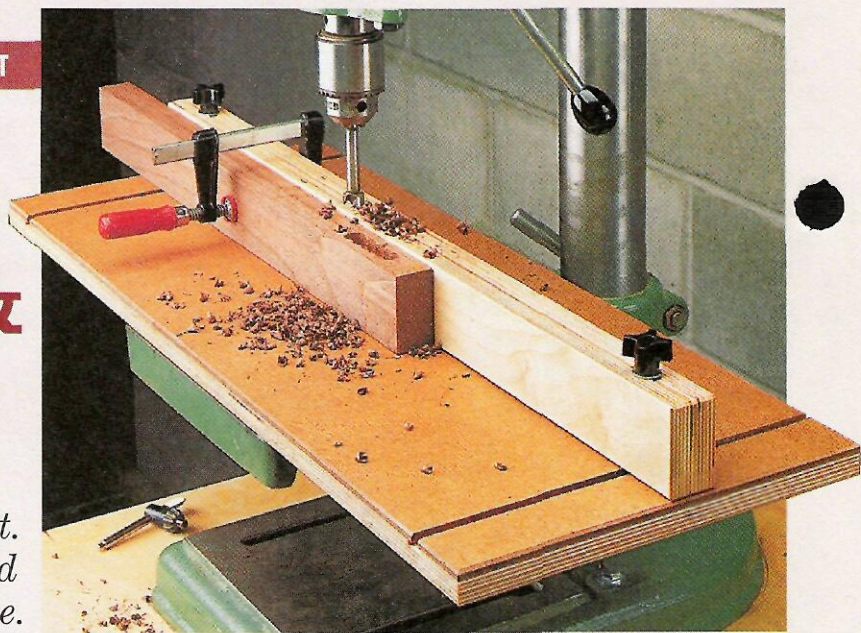

An auxiliary table. And an adjustable fence. Those are the first two improvements I'd make to a "bare bones" drill press.

Take this table for instance. It's much larger than the metal drill press table it's attached to. So it offers plenty of support when working with long pieces.

The table also lays the groundwork for an adjustable fence. To

position the fence quickly and accurately, it slides along two T-shaped slots in the table. And a built-in clamp locks it in place.

## TABLE

The table is made up of two layers. To add rigidity, there's a layer of 3/4"-thick plywood on the bottom. And a top layer of 1/4" hardboard creates a flat, durable

work surface.

There's also another advantage to this double-layered table. The top layer has a removable center piece (insert), see Fig. 1. When this insert gets chewed up with use, simply slide it in or out to expose a "fresh" drilling surface. Or replace it with a new insert.

**BASE.** I started on the table by making the plywood *base* (A), see Fig. 2. To form the first half of the T-slots, you'll need to cut two dados in the base, see Fig. 2a. Later, each of these dados will accept the head of a toilet bolt that guides the fence in the slot.

**INSTALL T-NUTS.** The next step is to install a set of T-nuts that are used to attach the base to the metal drill press table. To locate the holes for these T-nuts, start by setting the base on the drill press table. Then, after marking the location of the holes from underneath the table, drill counterbored shank holes and install the T-nuts.

**TOP.** Now you can concentrate on the top of the table. It consists of two *top* (B) pieces and the insert, see Figs. 1 and 2. Note: It's best to cut the top pieces oversize and trim them flush later.

To hold the insert in place, it fits into a dovetail-shaped opening in the top of the table. This opening is formed by cutting a bevel on the *inside* edge only of the top pieces, see Fig. 2b.

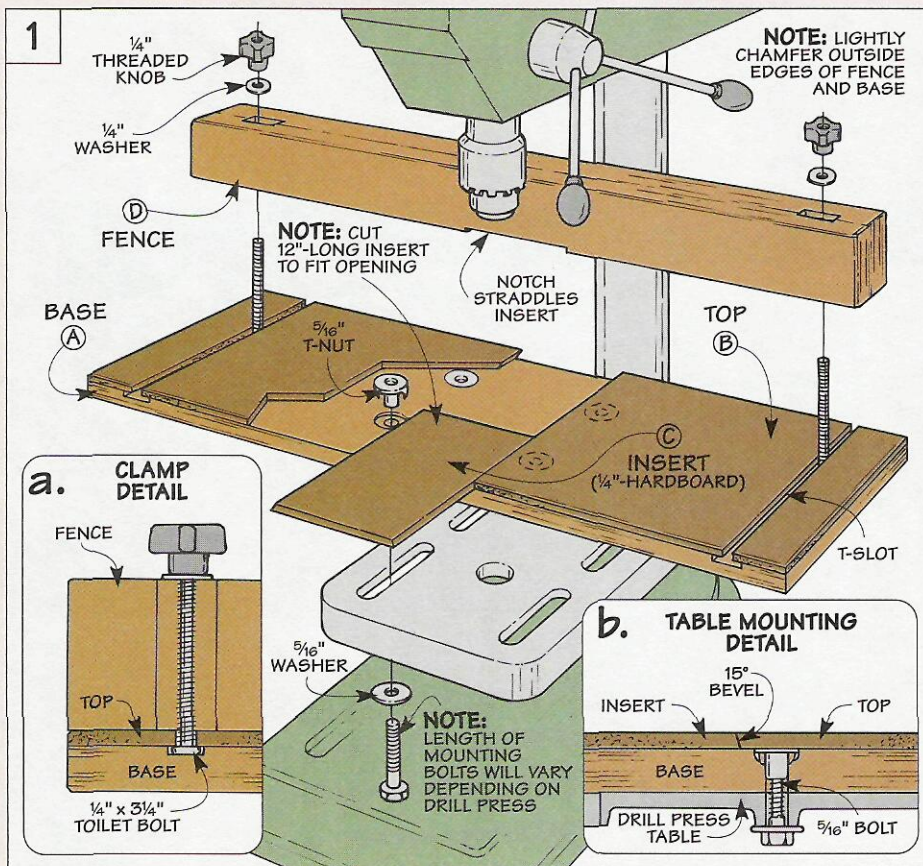

To prevent the insert from binding, the beveled edges of the top pieces need to be parallel to each other. A simple solution is to use a spacer when gluing on the top pieces, see page 30.

After trimming the edges flush, you can complete the second half of the T-slots. This is just a matter of cutting dados in the top pieces, see Figs. 3 and 3a.

Now all that's left is to cut an insert (C) to fit the opening in the table. To do this, you'll need to bevel both edges of the insert. While you're at it, it's a good idea to make several inserts so you'll have a few spares.

**FENCE**

After attaching the drill press table with bolts, the next step is to add the fence.

The thing I like best about this fence is you can adjust it without having to coax first one end and then the other. The reason has to do with a thin slot in each end of the fence. These slots form openings for the toilet bolts that guide the fence.

Why not just drill holes for the bolts? After all, it would be quicker. The only problem is if you don't move *both* ends of the fence the same amount when making an adjustment, the bolts would jam in the holes and cause the fence to bind.

But there's clearance between

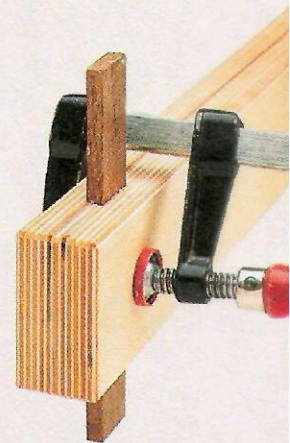
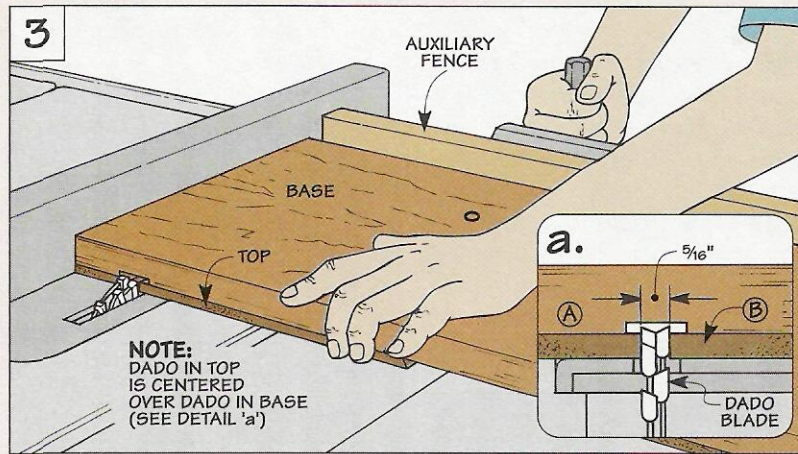
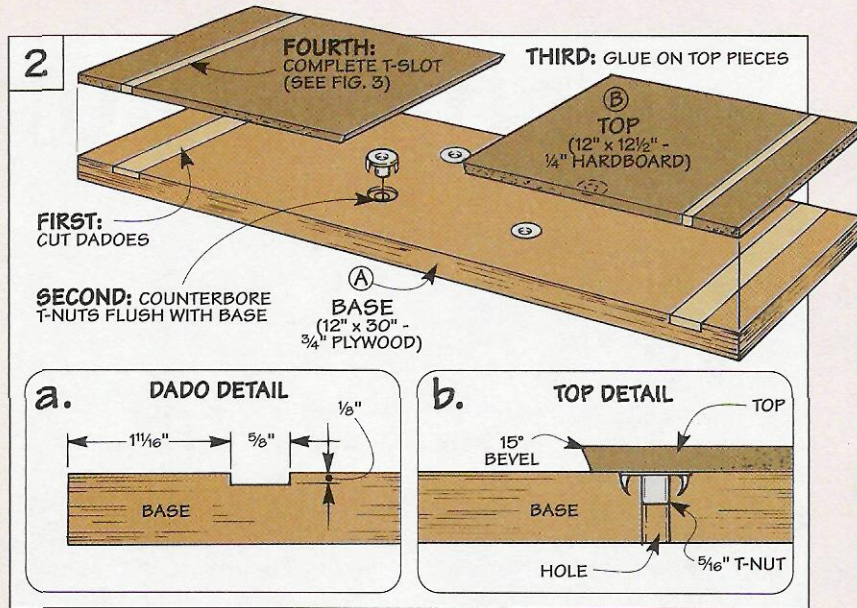

▲ A waxed "key" ensures proper alignment when gluing up the fence pieces.

the bolt and the ends of the slot. So even if both ends of the fence aren't perfectly aligned, it still slides nice and smooth.

**FENCE PIECES.** To make the fence, start by cutting two fence

pieces (D), see Fig. 4. The slot for the toilet bolts is formed by first cutting a pair of dados in each fence piece, then gluing the pieces together, see margin.

**NOTCH.** Before installing the fence, I cut a shallow notch in the bottom edge. In use, this notch straddles the insert in the table, see Figs. 1 and 4. This way, when the fence is tightened down, it won't apply pressure on the insert. So you'll still be able to slide the insert in or out.

**ATTACH FENCE.** Now all that's left is to attach the fence to the table. After slipping the toilet bolts in place, set the fence down over them. Tightening knobs on the ends of the bolts locks the fence in place. Ⓐ

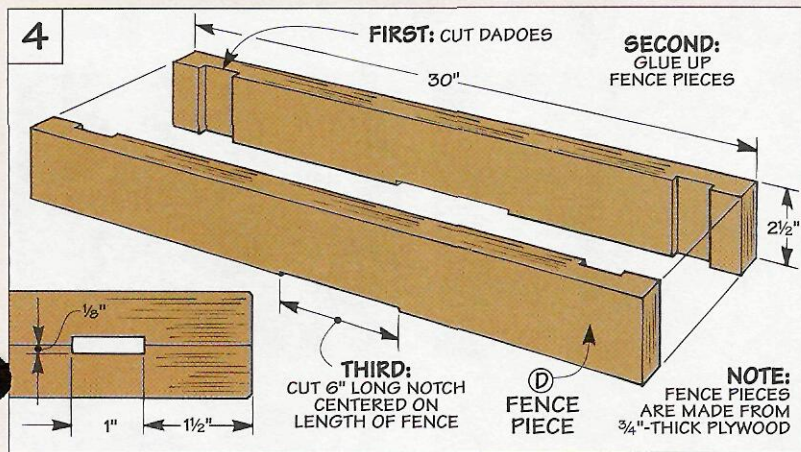

**Hardware**

- (2) 1/4" Threaded Knobs
- (2) 1/4" Washers
- (2) 1/4" x 3 1/4" Toilet Bolts
- (4) 5/16" T-Nuts
- (4) 5/16" Washers
- (4) 1/4" Wing Nuts

Note: You'll also need (4) 5/16" bolts to mount table to drill press (length will vary)

# Logs to Lumber

**L**et's face it — lumber isn't cheap. In fact, you don't have to pick up very many boards at the lumberyard before getting just a twinge of "sticker shock."

That explains why Ted (one of our project designers) is always on the lookout for a less expensive source of lumber. And usually, he doesn't have far to look.

**BACKYARD LUMBER.** Recently, he found a source of good quality lumber right in his own backyard. (Actually, it was a few blocks away from his backyard.) An oak tree had blown down at a nearby apartment building. So on his way to work one morning, he decided to check it out.

**SAW LOGS.** The tree looked like it had the potential to produce some good quality saw logs. The trunk measured about 20" in diameter at the base. And it was

straight with no major limbs for the first fifteen feet. Finally, he couldn't see any evidence of rot or insect damage.

After sizing up the tree and talking to the owner of the building, Ted decided to make a deal. He'd remove the tree from the yard. And in exchange, he'd get all the lumber from the tree.

**TREE REMOVAL.** Removing the tree started out simply enough. He cut the large limbs into firewood and hauled the branches away.

But after cutting the trunk into ten-foot lengths, there was

one big obstacle — how to transport the heavy logs. After all, he couldn't just wrestle them into his pickup.

**TREE SERVICE.** A call to a local tree service company solved the problem. They loaded the logs onto a truck, drove the few blocks to Ted's house, and dumped them in his front yard.

Okay, but wasn't that expensive? Not as much as you might expect. Altogether, it only cost \$65. And that was his only expense so far. Now he just needed a way to saw the logs into lumber.

Here again, this wasn't a job that Ted was set up to tackle. But fortunately, there are sawmills in almost every part of the country that will make quick work of sawing logs into lumber.

And many of these mills are *portable*. So the mill can easily



**1** The portable bandsaw mill is mounted on a trailer, so it's easily pulled up next to the logs.



**2** Using a cant hook at each end, the log is pivoted into position to load on the sawmill.



**3** After unhitching the trailer, it only takes a few minutes to level the sawmill using built-in jacks.



**4** Here again, a cant hook makes quick work of rolling the log onto two hydraulic arms.



**5** The arms cradle the log as they raise it off the ground and roll it onto the bed of the sawmill.



**6** A hydraulic "claw" (right) is used to rotate the log. And a foot (left) holds it securely in place.

be brought right to the logs.

**BANDSAW MILL**

To locate one of these mills, we called *Wood-Mizer*, a company that manufactures portable bandsaw mills. They offered to bring out one of their mills to show us how it works.

*Editor's Note:* To find the operator of a bandsaw mill in your area, you can call *Wood-Mizer* at 800-553-0182.

**PORTABLE.** A few weeks later, we got a glimpse of how portable these sawmills really are. The mill was mounted on a trailer that was pulled up right in front of Ted's house, see Step 1 on page 24.

**SETUP.** After jockeying the logs into position (Step 2), it was just a matter of setting up the sawmill. Within fifteen minutes, the trailer had been unhitched, and the mill was leveled and ready to go, see Step 3.

**LOADING LOGS.** We started by loading the logs onto the bed of the sawmill. This wasn't as difficult as it sounds. Especially since this mill had a number of

hydraulic controls that made it easy to handle the heavy logs, see Steps 4 through 6.

**INSPECTION.** Before making the first cut, we gave the log a thorough inspection. Finding a nail or chunk of wire embedded in the log now would prevent dulling (or breaking) a saw blade later.

**SQUARING UP THE LOGS.** Now we were ready to start making some sawdust. The initial cuts simply squared up the log, see Steps 7 and 8.

**MOVABLE SAW HEAD.** They also gave us a chance to see how the head of the saw traveled back and forth along the length of the log. (This is the opposite of most circular sawmills I'd seen where the log is carried through the blade.)

**CUSTOM CUTTING.** In addition to moving back and forth, the head of the saw also adjusts up and down. This way, the sawyer can cut boards to whatever thickness you want. (Ted had his logs cut into 2"-thick boards).

**DUST.** As the blade slices through the log, dust pours out a chute on the side of the mill, see

Step 9. And a trickle of water keeps the blade running cool, see Step 10.

With all this dust, it may appear that a lot of Ted's lumber was ending up on the ground as waste. But that's not the case.

**THIN KERF.** Unlike a circular saw blade, the bandsaw blade cuts an extremely thin kerf, see Step 11. So there's really less waste.

As a result, Ted got more lumber than he would have if the logs had been cut by a circular sawmill. In fact, he ended up with about 700 board feet altogether.

**COST.** How much did it cost? Although Ted didn't have to pay for the actual sawing, most sawyers charge about thirty cents per board foot of lumber.

So it would have cost him \$210 to have the logs cut into lumber. When you add in the \$65 he paid for the tree service, that comes to \$275. That figures out to be about forty cents per board foot. Not bad for a "windfall."

Of course, he wasn't done yet. The lumber still needed to be dried, refer to page 26.



**7** During the initial cut, the blade removes the top portion of the log (left). Then the log is rotated to square up the remaining sides (right).

**8** As the blade slices through the log (left), the feed rate is controlled by the sawyer (center). A gauge (right) helps determine the thickness of the board.

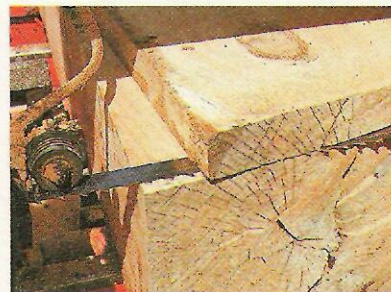
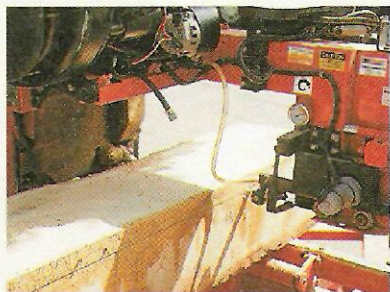

**9** Dust pours out a chute on the side of the mill as the head of the saw travels along a steel rail.

**10** To prevent pitch from gumming up the blade, a water-drip system keeps it running cool.

**11** A sharp blade and a mill that's properly aligned will produce quality boards like this.

# Air-Drying Lumber

**I**t was a two-person job to lift the heavy slabs of lumber as they were sliced off the logs by the sawmill. And the rough sawn surfaces felt wet to the touch.

That's because as much as *half* the weight of the boards was water. So before Ted could use the lumber to build a project, most of this water had to be removed.

Fortunately, he had the perfect place to *air-dry* his lumber — a screened porch on the side of his garage, see photo above.

**SHELTER.** Besides sheltering the wood from rain and snow, the porch shielded it from direct sun. This prevented the boards from drying *too* rapidly which would cause them to check (crack).

**AIR CIRCULATION.** The porch also allowed air to circulate which



would carry off the moisture produced by the drying lumber.

## STACKING LUMBER

But in order to accomplish that, the air had to move freely around *every* surface of each board. That required stacking the lumber in a careful manner.

**FOUNDATION.** Just like a well-built house, the lumber stack

needed a solid foundation. So Ted started by laying out a row of 4x4 posts that were spaced about 18" apart, see Step 1 below.

He also made it a point to check that the top surface of all the posts were even. If one post was lower, the boards above it would sag like an old horse. So to ensure that the boards dried flat, Ted laid a long, straight board across the posts and used shims to get everything nice and even.

**MOISTURE BARRIER.** With the posts in place, he laid down a sheet of  $\frac{3}{4}$ " plywood, see Step 2. The plywood stops dampness from wicking into the stack and damaging the boards at the bottom.

**STICKERS.** At this point, Ted disappeared for a few minutes. When he came back, he was carrying an armload of narrow wood strips (stickers).

Laying out a row of these stickers on the plywood allowed air to circulate under the bottom layer of boards, see Step 3. The rest of the stickers were used later to separate the individual layers of lumber.

One thing about these stickers is they weren't just any old scraps that Ted picked up around the shop. To keep the stickers from staining the boards, he made them from clean, dry "two-by" material. Note: Hardwood stickers would also work.



**1** To provide a solid foundation for the stack of lumber, start by laying out a row of 4x4 posts.



**2** Now lay down plywood to keep moisture from damaging the lumber at the bottom of the stack.



**3** A row of stickers will let air circulate between the plywood and the bottom layer of lumber.



**4** After setting the first layer of boards in place, just repeat the process as you build up the stack.

## LUMBERYARD

**FIRST LAYER.** With the basic groundwork complete, Ted was ready to set the first layer of boards in place. Once again, leaving at least an inch of space between boards allowed the air to circulate.

**BUILDING THE STACK.** At this point, the lumber stack started to take shape quickly — another row of stickers followed by a layer of boards, see Step 4.

As Ted built up the stack, he kept the stickers in straight vertical rows — directly over the 4x4 posts. This way, the weight of the lumber transferred down through the stack to the posts.

**MORE PLYWOOD.** At the top of the stack, he added one more piece of plywood, see Step 5. This panel keeps any moisture that gets into the porch off the top layer of boards.

But more important, it slowed down the drying time of these boards by covering their exposed surfaces. Without the plywood, the air moving across the boards would remove moisture too rapidly and cause them to check.

**CONCRETE BLOCKS.** The boards at the top of a stack are also more likely to *warp*. The reason is simple. Unlike the boards buried in the stack, there's no weight pressing down on them from lumber above. So to keep

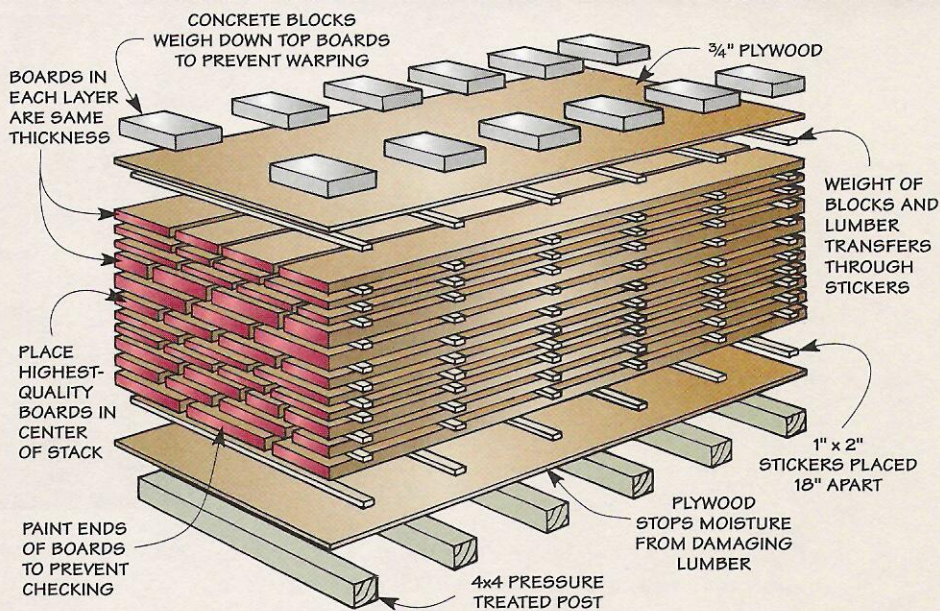

the top boards flat, Ted set heavy concrete blocks on top of the plywood, see Step 6.

**PAINT ENDS.** Finally, Ted coated the end of each board with latex paint, see Step 7. The paint served an important purpose. It minimized checking by preventing moisture from blowing out the ends of the boards too rapidly. Instead, the moisture escapes much more slowly from the edges and faces of the boards.

### TIME

After building the stack, Ted only had one thing left to do — allow the lumber time to dry.

Just how much time? The old rule of thumb is about a year per inch of lumber thickness. So to dry his 2"-thick boards, he figured it would take about two years.

But that's really just a guess.

**MOISTURE METER.** The only way to know for sure is to check the lumber from time to time with a moisture meter. (For more information on moisture meters, refer to *ShopNotes* No. 30.)

A meter will give the exact moisture content of the lumber. Ideally, the boards should be around 6% to 8%.

But as long as the lumber was exposed to the humidity of the outside air, it would never reach that ideal moisture content. The best Ted could hope for would be around 15% to 20%.

**STACK INDOORS.** So when the lumber eventually does reach that point, Ted will still have one more thing to do — move it indoors to a heated location where the final drying can be completed. 🛠️



**5** Adding a final piece of plywood keeps the top layer of lumber from drying too quickly.



**6** The stack is weighted down with concrete blocks to prevent the top boards from warping.

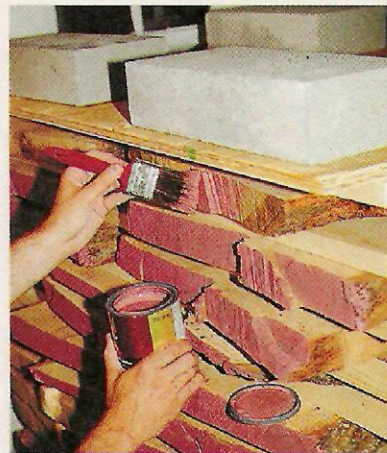

**7** To minimize checking caused by losing moisture too rapidly, paint the ends of the boards.

# Finishing on the Lathe

*Quick and easy — that's the best way to describe the task of adding a finish to a turned project.*

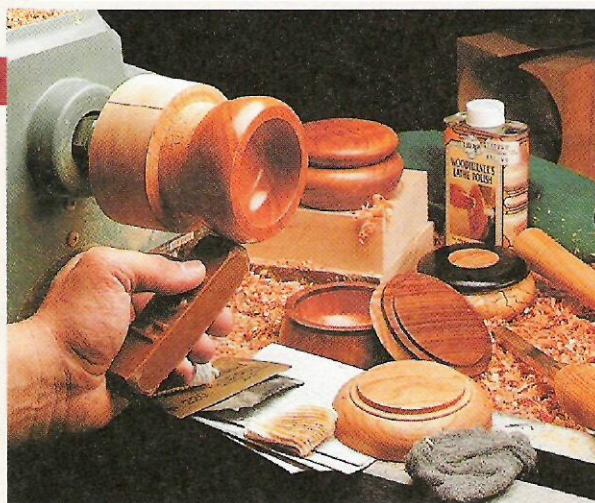

**T**urning a project to shape on a lathe is very satisfying. But what's even more satisfying is how fast and easy it is to apply the finish — while the project is still on the lathe.

**SANDING.** But before you can apply the finish, you'll need to sand the project. Even with sharp tools, there will still be some tool marks left behind. And you might end up with some tearout in the end grain that needs to be removed.

The important thing is to start with the coarsest grit that will remove both the tool marks and any tearout. For a spindle-turned project, I start with 150-grit. But to smooth the end grain in a faceplate project, it's best to start with 80-grit.

Then it's just a matter of using progressively finer grits. But be sure to remove all the scratch marks of the previous grit first before going on.

After removing the tool rest, sand the workpiece at the bottom using a small piece of sandpaper, see photo A below. This way, if it catches on the workpiece, the sandpaper gets pulled from your hand before it can pull your fingers into the workpiece.

**BURNISHING.** Once the sanding is complete, I like to burnish (polish) the wood to bring out its natural sheen. This is easy to do with a handful of shavings cupped in the palm of your hand, see photo B below. Simply hold the shavings firmly

against the workpiece as it's turning.

**FINISH.** All that's left is to add the finish. There are a wide variety of turning finishes available, see margin and mail order sources on page 31. The main thing to keep in mind in choosing a finish is how much handling the project is going to receive.

**WAX.** For a project that isn't handled on a daily basis, I'll use either a hard or soft wax. A soft paste wax is simply applied to the workpiece by hand using a small cloth. Then to buff it out and remove the excess, turn the lathe on and hold a small piece of clean cloth against the workpiece.

The hard wax works a little differently. It comes in the form of a stick. So it's used like a crayon to apply a thin coat while the workpiece is turning, see photo above. Then, like the soft wax, hold a small cloth against the workpiece. The friction generated will melt the wax and distribute it evenly.

**LIQUID FINISH.** For projects that need a bit more protection, I prefer a liquid finish. It provides a more durable surface film. And I can build up several coats in a few hours.

To avoid having the finish spray off the project, I apply it with the lathe turned off. This way, it has time to soak in and doesn't dry unevenly. Once the finish is applied, turn on the lathe and use a cloth to distribute the finish, see photo C.

This evens out the finish. And the heat that's generated helps the solvents evaporate. This allows you to apply a few coats in a short period of time.



*Finishing on the lathe is a simple process — the key is matching the finish to the project.*



**A. Sanding.** Hold the sanding pad along the bottom of the workpiece and sand with the rotation.

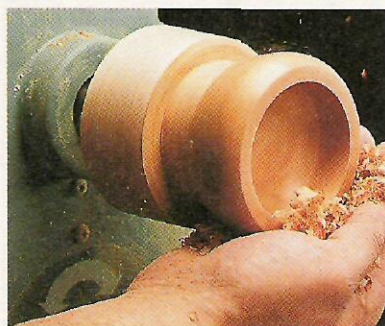

**B. Burnishing.** To produce a nice sheen, hold a handful of shavings against the workpiece as it turns.



**C. Finishing.** After applying a finish, use a cloth to distribute it evenly as the workpiece turns.

# Making a Jam Chuck

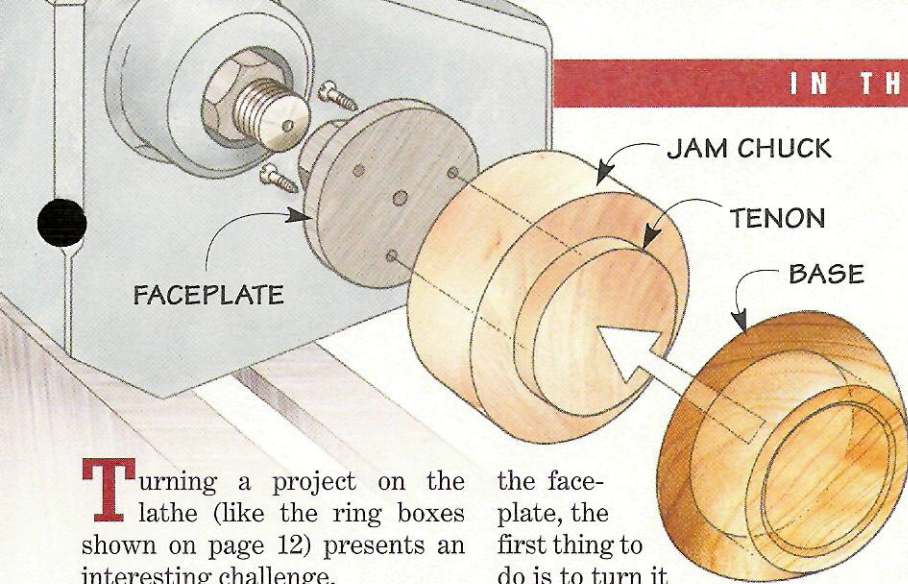

**T**urning a project on the lathe (like the ring boxes shown on page 12) presents an interesting challenge.

That's because the insides of the base are scooped out first. Then, after removing the base from the lathe, the hollowed out end needs to be remounted so you can turn the bottom.

This is the challenging part. How do you mount the open end of the base to the lathe without using a specialized chuck?

**JAM CHUCK.** The solution is a simple "jam" chuck. Basically, this is just a block of wood with a round tenon. The tenon fits *inside* the opening of the base and holds it in place with a friction fit.

To make a jam chuck, I usually glue up a block from pieces of 3/4"-thick stock. The block is simply screwed to the metal faceplate that threads onto the lathe.

Once the block is secured to

the faceplate, the first thing to do is to turn it to a cylinder. (I use a square-end scraper.) Then true up (flatten) the face of the jam chuck.

**TENON.** Now you're ready to turn the tenon. The goal is to get the tenon to fit *tight* inside the base. The only problem is the difference between a tight fit and one that's too loose is less than the thickness of a piece of paper.

So the best way to get a good fit is by *feel*. To do this, you'll need to sneak up on the final size of the tenon by making a series of small cuts, see detail 'a' below.

One more thing. When you're trying to get the tenon to fit in the opening, it's best to cut a short (1/16") tenon. This way, if you remove too much material (and the fit is too loose), you can true up the face of the jam chuck and

try again without much waste. **TAPER.** Once you're satisfied with the fit, the next step is to *taper* the tenon (about one or two degrees) as you cut it to full depth, see detail 'b.' This allows you to "wedge" the base onto the tenon.

To complete the jam chuck, there's one last thing I like to do. I flatten the angled shoulder that's formed when the taper is cut, see detail 'c.'

**MOUNT BASE.** Now you're ready to mount the base on the jam chuck. Start by pressing it firmly onto the tenon. Note: As long as the base is secure, it doesn't need to sit flat against the face of the jam chuck.

Then turn the lathe *by hand* to check that the base is centered. If it's not, just tap the "high" side a few times with a mallet. Then, flip the lathe on and off quickly to make sure that the base is secure before you start turning.

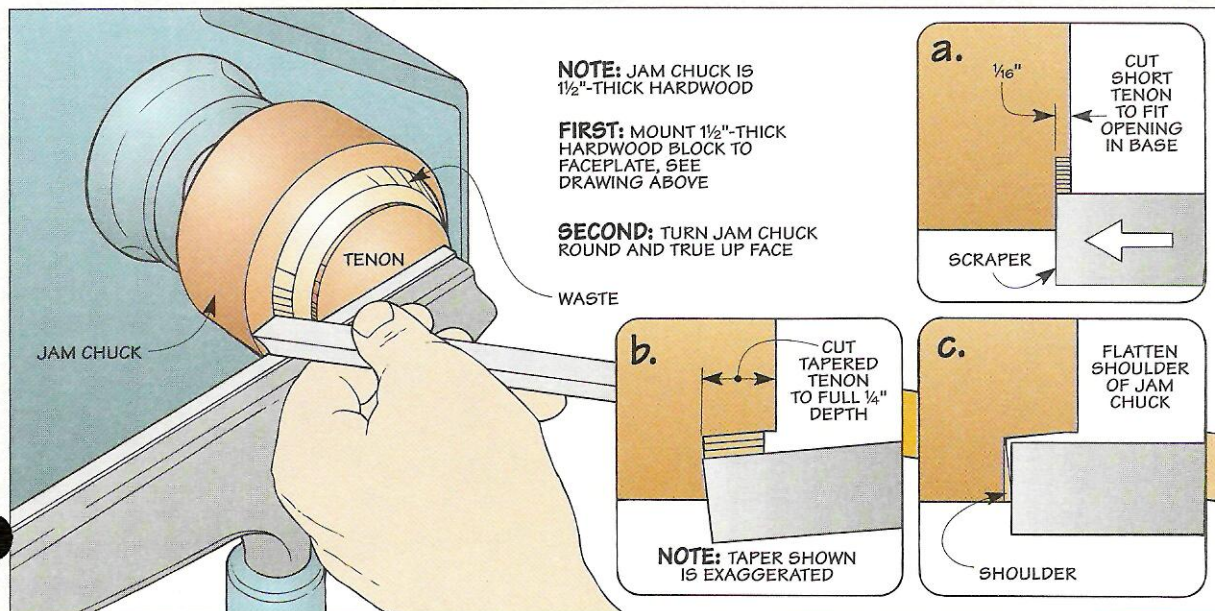

## GLUE-UP TIP

■ Gluing the top pieces to the base of the Drill Press Table (page 22) is easy. The trick is making sure the inside (beveled) edges on each piece are *parallel*. This ensures that the insert (with its matching bevels) will slide smoothly into the opening.

**SPACER.** To help position the top pieces, I clamped a 3/4"-thick plywood spacer to the base. Note: To create the desired size opening in the table, I ripped the spacer 5" wide.

Why not just make the insert and use it as a spacer? Because when you butt the two pieces together, the bevel on the top piece would have a tendency to "ride up" over the bevel on the insert.

But the edges of the plywood spacer are square. Plus it's taller (thicker) than the hardboard insert. This makes it a snap to position each top piece during glue-up. Just push the beveled edge firmly against the spacer as you lower it onto the base of the table, see drawing.

**CLAMPING STRIPS.** One thing to keep in mind here is the jaws on most clamps aren't deep enough to apply pressure at the center of the table. So to dis-

## ALIGNMENT JIG

■ When gluing two pieces face to face, they tend to slip and slide out of alignment as you tighten the clamps.

One solution is to install a short brad in one piece and snip off the head. This cutoff brad sticks into the mating piece and keeps it from shifting.

But sometimes the brad grabs too soon — *before* the pieces are properly positioned. This makes it even more difficult to align the pieces. And you end up with a gluey mess.

So before gluing up the two

Press Stand (page 16), I used a simple jig along with the brads to align the pieces.

Basically, it consists of two *sides* and a *base* that are screwed together to form a 90° corner, see drawing.

The idea is to set one leg piece with a couple of cutoff brads in the corner. Then hold the mating piece against the brads and press it onto the brads.

This forms two tiny indentations that are easy to "find" when you glue up the two leg pieces. And you can be sure the halves will be perfectly aligned.

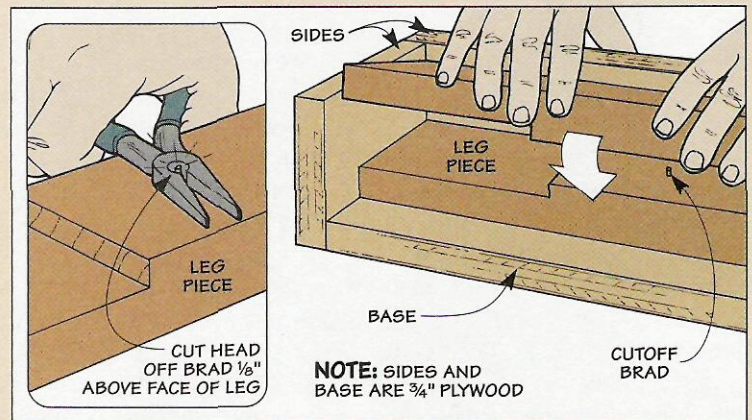

tribute pressure evenly across the table, I clamped strips of wood against the top.

**TRIM FLUSH.** Once the glue dries, there's one last thing to do.

That's to trim the overhanging edges of the top pieces flush with the base. A flush trim bit in a table-mounted router makes quick work of this.

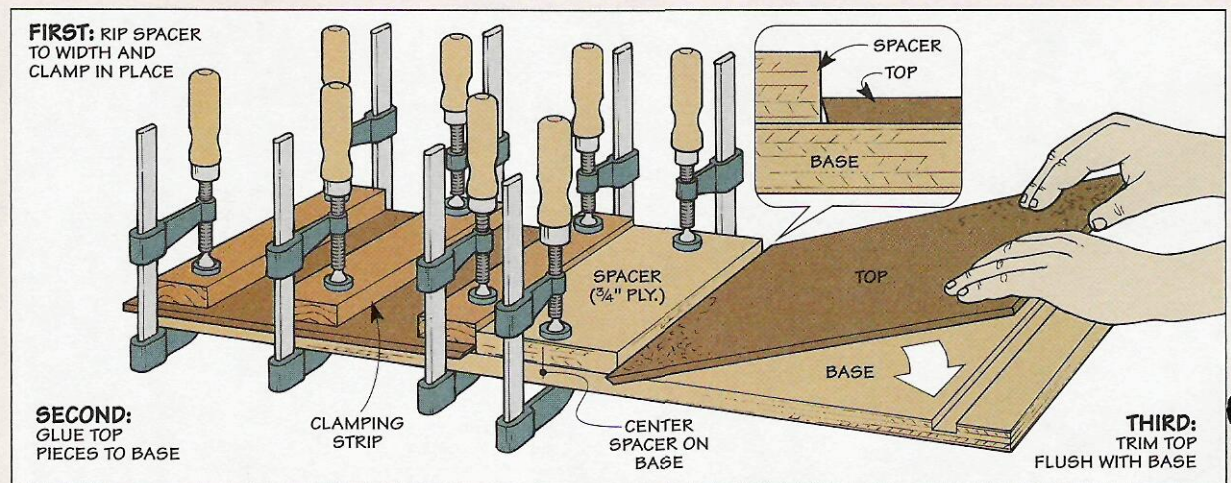

# Sources

## PRODUCT INFORMATION

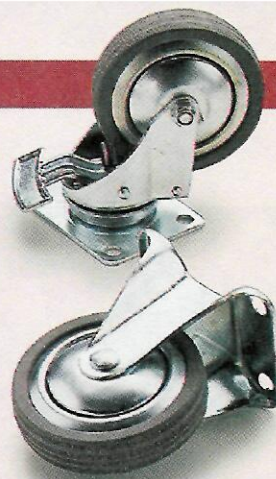

### Heavy-Duty Casters ▶

The heavy-duty casters we used for the Benchtop Drill Press Stand (page 16) are ideal for roll-around tool bases.

They're available as either a *fixed* or a *locking* swivel caster. The nice thing about the locking caster is it locks both the wheel *and* the shaft. For mail-order sources, see margin.

## MAIL ORDER SOURCES

**Lee Valley Tools**  
800-871-8158  
*Scraper Burnisher, Scrapers, Casters*

**Packard Woodworks**  
800-683-8876  
*Scraper Burnisher, Finishing Supplies, Scrapers*

**Craft Supplies**  
800-551-8876  
*Finishing Supplies, Scrapers*

**Woodworker's Supply**  
800-645-9292  
*Finishing Supplies, Scrapers*

*ShopNotes Project Supplies is offering some of the hardware and supplies needed to build the projects in this issue.*

*We've also put together a list of other mail order sources that have similar hardware and supplies.*

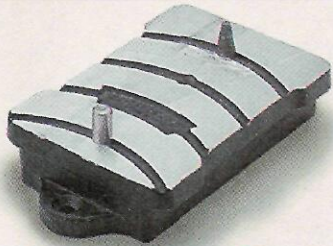

### ▲ Scraper Burnisher

This Scraper Burnisher puts a strong, sharp burr on a scraper that's used when turning a project on the lathe. And it works great with high-speed steel tools. It's made by *Veritas* and is available through the mail-order sources listed at right.

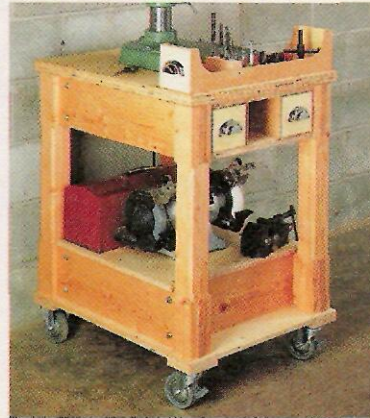

### ◀ Drill Press Stand

The Drill Press Stand featured on page 16 and the Table & Fence shown on page 22 provide a complete workstation for your benchtop drill press.

*ShopNotes Project Supplies* is offering a hardware kit to build the Benchtop Drill Press Stand, the Table, and the Fence. It includes all the hardware you need to build each project except for the casters.

**DRILL PRESS KIT**  
6838-100.....\$19.95

### Selected Guide to Our Best Shop-Made Tool Stands

*These sturdy tool stands featured in past issues of ShopNotes will help dampen noise and vibration and improve the performance of your tools.*

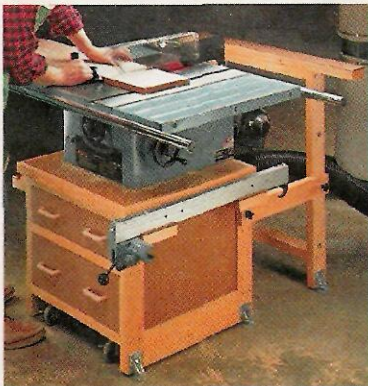

### ▲ Table Saw Cabinet

Besides adding storage, this Table Saw Cabinet features an outfeed support as well as built-in dust control.

We're offering a kit with all the hardware needed to build the Table Saw Cabinet. *ShopNotes* No. 25 is also included to provide step-by-step plans.

**TABLE SAW CABINET KIT**  
6825-225.....\$149.95

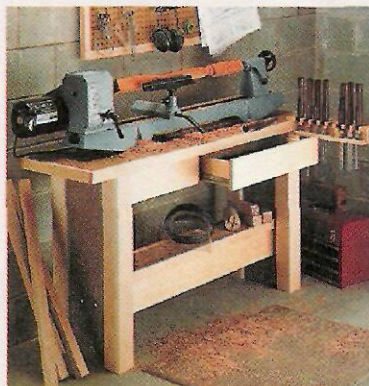

### ▲ Lathe Stand

This shop-built Lathe Stand has a massive top, solid slab legs, and a heavy "sandbox" to help absorb vibration set up by the lathe.

A complete hardware kit (with plans provided in *ShopNotes* No. 10) is available to build this Lathe Stand.

**LATHE STAND KIT**  
6810-225.....\$39.95

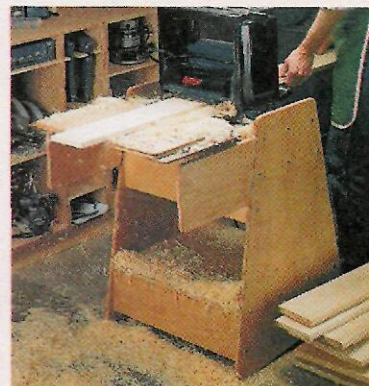

### ▲ Portable Planer Stand

You can make your portable planer *truly* portable with this mobile Planer Stand. It also offers an outfeed extension and an optional drawer.

We're offering a complete hardware kit to build the Planer Stand. *ShopNotes* No. 9 is included with complete plans.

**PLANER STAND KIT**  
6809-225.....\$29.95

TO PLACE AN ORDER, PLEASE CALL  
**800-347-5105**  
(KEY CODE: SN38)

## Scenes from the Shop

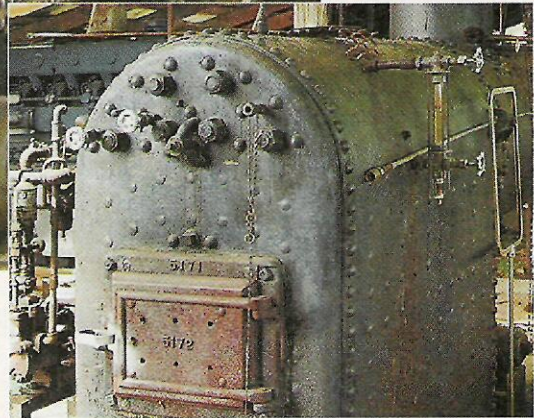
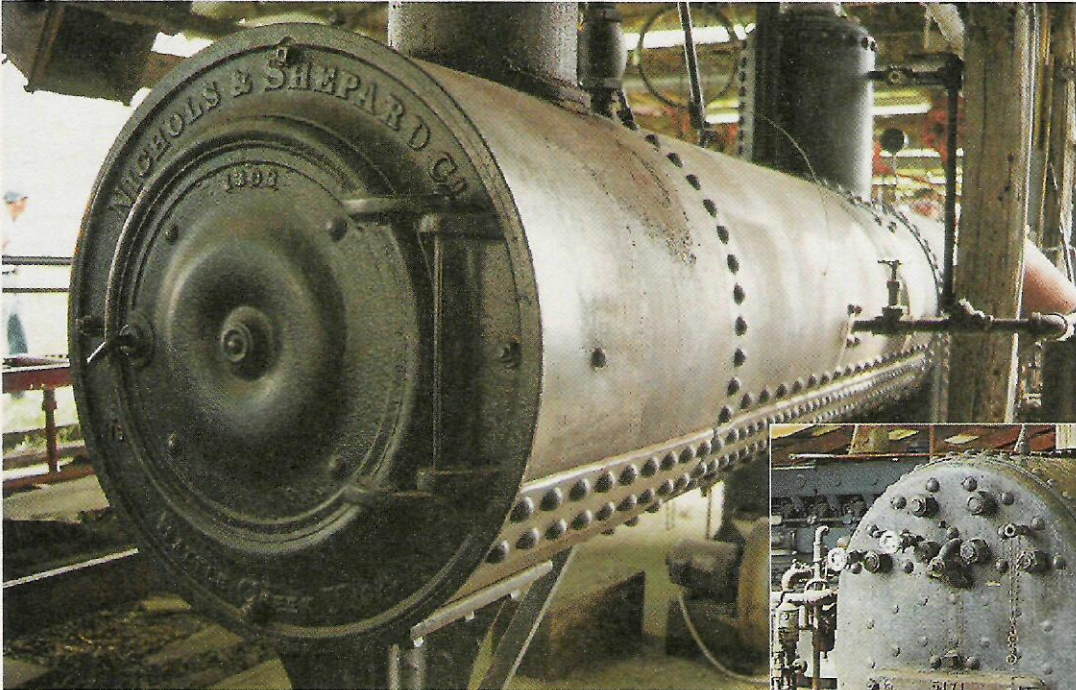

▲ Built around the turn of the century, this huge, wood-fired boiler stands like a derailed locomotive. Nevertheless, it continues to be a real workhorse today by generating the steam used to run the engine and sawmill shown below.



▲ With its two massive flywheels turning, this 60 hp Wright Adams steam engine (above) transfers power to the sawmill by means of a wide belt. As the rack and pinion drive on the sawmill is engaged (right), the saw blade slices into the log.